

CODES AND STANDARDS ENHANCEMENT INITIATIVE (CASE)

Final Report

Nonresidential Demand Responsive Lighting Controls

Demand Response 2: Nonresidential DR Lighting Controls

2013 California Building Energy Efficiency Standards

California Utilities Statewide Codes and Standards Team

June 2013

Joshua Rasin



This report was prepared by the California Statewide Utility Codes and Standards Program and funded by the California utility customers under the auspices of the California Public Utilities Commission.

Copyright 2012 Pacific Gas and Electric Company, Southern California Edison, SoCalGas, SDG&E.

All rights reserved, except that this document may be used, copied, and distributed without modification.

Neither PG&E, SCE, SoCalGas, SDG&E, nor any of its employees makes any warranty, express of implied; or assumes any legal liability or responsibility for the accuracy, completeness or usefulness of any data, information, method, product, policy or process disclosed in this document; or represents that its use will not infringe any privately-owned rights including, but not limited to, patents, trademarks or copyrights

Table of Contents

Preface1

Executive Summary1

 Final Code Language 1

 Evolution of Requirements..... 2

 Energy Savings 2

Final Adopted Language.....3

 Building Energy Efficiency Standards 3

 Reference Appendices..... 6

 Alternate Calculation Method (ACM) Manual..... 8

 Nonresidential Compliance Manual..... 8

 Compliance Forms 12

Energy Savings Estimates16

Acknowledgments18

Appendix Preliminary CASE Report19

Document information

Category: Codes and Standards

Keywords: PG&E CASE, Codes and Standards Enhancements, Title 24, 2013, efficiency

Preface

The Codes and Standards Enhancement (CASE) initiatives present recommendations to support the California Energy Commission's efforts to update the Title 24 Standards to include or upgrade requirements for various technologies in California's Building Energy Efficiency Standards. The four California Investor Owned Utilities - Pacific Gas and Electric Company, San Diego Gas and Electric, Southern California Edison and Southern California Gas Company - sponsored this effort. The program goal is to prepare and submit proposals that will result in valuable, cost-effective enhancements to energy efficiency in buildings. This report, Demand Responsive Lighting Controls, is one of several cross-cutting proposals now included in the 2013 Building Energy Efficiency Standards.

Executive Summary

The Demand Responsive Lighting Controls measure enlarges the scope of buildings that are required to install demand response (DR) capabilities for lighting loads. The proposal expands the buildings that are required to comply by lowering the floor size threshold and including all nonresidential building types. The threshold is revised from retail sales floors larger than 50,000 square feet to all nonresidential buildings greater than 10,000 square feet. The installation of this technology allows for users to enroll and participate in DR events and respond to price signals. The controls would respond to a DR signal with a reduction of lighting power by a minimum of 15 percent of the total installed lighting power. Once enrolled in a DR program, users maintain the ability to opt out of each individual DR event; they may also choose to shed a larger load than 15 percent of the total installed lighting power and can override the reduction at any time during the event.

This proposal results in modifications to Section 130.1(e), 130.5(e) and TABLE 140.6-A of the 2013 Title 24 Building Energy Efficiency Standards, the Appendices, the Nonresidential Compliance Manual, and compliance forms.

Final Code Language

Section 130.1(e) of the final Code language requires commercial buildings larger than 10,000 square feet to install demand responsive (DR) technology that is capable of automatically reducing the lighting load within a building upon receiving a demand response signal. The load shed requirement is for a minimum of 15 percent reduction in lighting power from the total installed lighting power of the building, not including the lighting load in spaces that are non-habitable or have a lighting power density less than 0.5 watts per square foot. According to Section 130.5(e), the installed DR equipment must be compatible with at least one standards-based messaging protocol.

TABLE 140.6-A Lighting Power Adjustment Factors - Allows for an adjustment of 0.05 watts per square foot in buildings less than 10,000 square feet that install DR controls for lighting.

New definitions for demand response, demand response signal, and demand responsive control were added to Section 100.1 in coordination with CASE efforts for the Occupant Controlled Smart Thermostats (OCST) measure.

Evolution of Requirements

The proposed code language for Section 130.1(e) was slightly altered by the CEC without disrupting the intent of the Standard. The originally proposed language listed separate specifications for reducing lighting power through continuous dimming systems and step dimming or switching systems. The revised requirement simply states that all systems are required to comply with the multi-level lighting controls and uniformity requirements listed in Table 130.1-A to achieve at least a 15 percent reduction in lighting power. This will eliminate any confusion for multi-level lighting specifications and keep the requirements consistent.

Initial stakeholder feedback indicated a preference for the proposal to remove the reduction threshold requirements, and only require the lighting system to have demand responsive capabilities. However, the response by the CEC and the California building officials that are responsible for enforcing the standards indicated that a threshold requirement would be necessary for the enforcement of the requirements.

The exception to Section 130.1(e) for luminaires that are already receiving a signal, such as a photocontrol, and are unable to receive an additional signal was deemed unnecessary and was not adopted. In practice, designers would automatically account for these limitations when deciding on the design and technology to use.

The adopted TABLE 140.6-A includes a single Power Adjustment Factor (PAF) for installing DR controls in buildings smaller than 10,000 square feet. The proposed language in the docketed CASE report retained the two PAFs from the 2008 Standards, one for DR lighting controls used on their own and another for DR controls used in combination with manual dimming of electronic ballasts. The latter PAF was dropped in the adopted language, as the PAF for manual dimming became unnecessary, as it is essentially mandatory in adopted code.

The proposed requirement for Section 130.5(e) mandates the use of a nationally recognized open communication standard. The requirement was changed to mandate the use of a standards-based messaging protocol rather than an open communication standard. A standards-based messaging protocol guards against the development of proprietary messaging software, which maintains the intent of the standards language.

Energy Savings

The statewide impact of this code proposal is 0.779 Gigawatt-hours per year and 3.25 Megawatts of electrical demand. The net present value of life cycle energy cost savings over 15 years will be approximately \$12,749,019.

Table 1. Statewide Energy Impacts Estimate for Demand Responsive Lighting Controls

Total Electric Energy Impacts (GWh/yr)	Total Power Demand Impacts (MW)	Total Gas Energy Impacts (Mtherms)
0.779	3.25	-

Final Adopted Language

Final adopted language for the standards, Compliance Manual, and Compliance Forms includes section number and original language in black font. Edits to the original language are notated as follows:

- Changes to the original 2008 Title 24 standards: single underline or ~~single strike-out~~
- Changes to the 45-day language: double underline or ~~double strike-out~~
- Changes to 15-day language: gray highlighted underline or gray highlighted ~~double strike-out~~

Building Energy Efficiency Standards

SECTION 100.1 – DEFINITIONS AND RULES OF CONSTRUCTION

~~DEMAND RESPONSE is controlling electricity loads in buildings in response to an electronic signal sent by the local utility requesting their customers to reduce electricity consumption.~~

DEMAND RESPONSE is short-term changes in electricity usage by end-use customers, from their normal consumption patterns. Demand response may be in response to:

- changes in the price of electricity; or
- participation in programs or services designed to modify electricity use
 - in response to wholesale market prices or
 - when system reliability is jeopardized.

~~DEMAND RESPONSE PERIOD is a period of time during which the local utility is curtailing electricity loads are modified in response to by sending out a demand response signal.~~

~~DEMAND RESPONSE SIGNAL is an electronic signal sent out by the local utility indicating a request to their customers to curtail electricity consumption.~~

DEMAND RESPONSE SIGNAL is a signal sent by the local utility, Independent System Operator (ISO), or designated curtailment service provider or aggregator, to a customer, indicating a price or a request to modify electricity consumption, for a limited time period.

~~DEMAND RESPONSIVE LIGHTING CONTROL is a control that reduces lighting power consumption in response to a demand response signal.~~

DEMAND RESPONSIVE CONTROL is a kind of control that is capable of receiving and automatically responding to a demand response signal.

SECTION 130.1 – INDOOR LIGHTING CONTROLS THAT SHALL BE INSTALLED

(e) Demand Responsive Controls.

~~1. In buildings larger than 10,000 square feet, lighting required to comply with Section 130.1(b) shall be capable of being automatically reduced by a demand responsive lighting control as follows:~~

~~A. By a minimum of 15 percent of full power for continuous dimming systems; or~~

~~B. By one level below full ON in accordance with Table 130.1-A for stepped dimming or stepped switching.~~

Lighting power in buildings larger than 10,000 square feet shall be capable of being automatically reduced in response to a demand responsive signal, so that the building's total lighting power can be lowered by a minimum of 15 percent below the maximum total lighting power. Lighting shall be reduced in a manner consistent with uniform level of illumination requirements in TABLE 130.1-A.

Spaces that are non-habitable shall not be used to comply with this requirement, and spaces with a lighting power density of less than 0.5 watts per square foot shall not be counted toward the building's total lighting power.

Table TABLE 130.1-A MULTI-LEVEL LIGHTING CONTROLS AND UNIFORMITY REQUIREMENTS

Luminaire Type	Minimum Required Control Steps (percent of full rated power ¹)	Uniform level of illuminance shall be achieved by:			
Line-voltage sockets except GU-24	Continuous dimming 10-100 percent				
Low-voltage incandescent systems					
LED luminaires and LED source systems					
GU-24 rated for LED					
GU-24 sockets rated for fluorescent > 20 watts	Continuous dimming 20-100 percent				
Pin-based compact fluorescent > 20 watts ²					
GU-24 sockets rated for fluorescent < 20 watts	Minimum one step between 30-70 percent	Stepped dimming; or Continuous dimming; or Switching alternate lamps in a luminaire			
Pin-based compact fluorescent < 20 watts ²					
Linear fluorescent and U-bent fluorescent < 13 watts					
Linear fluorescent and U-bent fluorescent > 13 watts	Minimum one step in each range:				Stepped dimming; or Continuous dimming; or switching alternate lamps in each luminaire, having a minimum of 4 lamps per luminaire, illuminating the same area and in the same manner
	20-40 %	50-70 %	80-85 %	100 %	
Track Lighting	Minimum one step between 30 - 70 percent				Step dimming; or Continuous dimming; or Separately switching circuits in multi-circuit track with a minimum of two circuits.
HID > 20 watts	Minimum one step between 50 - 70 percent	Stepped dimming; or Continuous dimming; or Switching alternate lamps in each luminaire, having a minimum of 2 lamps per luminaire, illuminating the same area and in the same manner.			
Induction > 25 watts					
Other light sources					
1. Full rated input power of ballast and lamp, corresponding to maximum ballast factor					
2. Includes only pin based lamps: twin tube, multiple twin tube, and spiral lamps					

SECTION 130.5 –ELECTRICAL POWER DISTRIBUTION SYSTEMS

(e) Demand Response Signals. Demand response signals shall conform to a standard in the National Institute of Standards and Technology (NIST) Smart Grid Interoperability Panel (SGIP) Catalog of Standards (CoS) and as approved by the Executive Director.

Demand responsive controls and equipment. Demand responsive controls and equipment shall be capable of receiving and automatically responding to at least one standards based messaging protocol which enables demand response after receiving a demand response signal.

SECTION 140.6 – PRESCRIPTIVE REQUIREMENTS FOR INDOOR LIGHTING

TABLE 140.6-A LIGHTING POWER DENSITY ADJUSTMENT FACTORS (PAF)

TYPE OF CONTROL		TYPE OF AREA	FACTOR
<p>a. To qualify for any of the Power Adjustment Factors in this table, the installation shall comply with the applicable requirements in Section 140.6(a)2</p> <p>b. Only one PAF may be used for each qualifying luminaire unless combined below.</p> <p>c. Lighting controls that are required for compliance with Part 6 shall not be eligible for a PAF</p>			
1. Partial-ON Occupant Sensing Control		Any area < 250 square feet enclosed by floor-to-ceiling partitions; any size classroom, conference or waiting room.	0.20
2. Occupant Sensing Controls in Large Open Plan Offices		In open plan offices greater than 250 square feet: One sensor controlling an area that is:	No larger than 125 square feet
			From 126 to 250 square feet
			From 251 to 500 square feet
3. Dimming System	Manual Dimming	Hotels/motels, restaurants, auditoriums, theaters	0.10
	Multiscene Programmable		0.20
4. Demand Responsive Control		All building types less than 10,000 square feet. Luminaires that qualify for other PAFs in this table may also qualify for this demand responsive control PAF	0.05
5. Combined Manual Dimming plus Partial-ON Occupant Sensing Control		Any area < 250 square feet enclosed by floor-to-ceiling partitions; any size classroom, conference or waiting room	0.25

Reference Appendices

NA7.6.7 Acceptance tests for Demand Responsive Controls in accordance with Section 130.1(e).

NA7.6.7.1 Construction Inspection

Prior to Functional testing, verify and document the following:

- That the demand responsive control is capable of receiving a demand response signal directly or indirectly through another device and that it complies with the requirements in Section 130.5(e).
- If the demand response signal is received from another device (such as an EMCS), that system must itself be capable of receiving a demand response signal from a utility meter or other external source.

NA7.6.7.2 Functional testing of Demand Responsive Lighting Controls

For buildings with up to seven (7) enclosed spaces requiring demand responsive lighting controls, all spaces shall be tested. For buildings with more than seven (7) enclosed spaces requiring demand responsive lighting controls, sampling may be done on additional spaces with similar lighting systems. If the first enclosed space with a demand responsive lighting control in the sample group passes the acceptance test, the remaining building spaces in the sample group also pass. If the first enclosed space with a demand responsive lighting control in the sample group fails the acceptance test the rest of the enclosed spaces in that group must be tested. If any tested demand responsive lighting control system fails it shall be repaired, replaced or adjusted until it passes the test.

Test the reduction in lighting power due to the demand responsive lighting control using one or the following two methods.

Method 1: Illuminance Measurement. Measure the reduction in illuminance in enclosed spaces required to meet Section 131(b), as follows:

- In each space, select one location for illuminance measurement. The chosen location must not be in a primary skylit or sidelit area. When placed at the location, the illuminance meter must not have a direct view of a window or skylight. If this is not possible, perform the test at a time and location at which daylight illuminance provides less than half of the design illuminance. Mark each location to ensure that the illuminance meter can be accurately located.
- Full output test
 - Using the manual switches/dimmers in each space, set the lighting system to full output. Note that the lighting in areas with photocontrols or occupancy/vacancy sensors may be at less than full output, or may be off.
 - Take one illuminance measurement at each location, using an illuminance meter.
 - Simulate a demand response condition using the demand responsive control.
 - Take one illuminance measurement at each location with the electric lighting system in the demand response condition.
 - Calculate the area-weighted average reduction in illuminance in the demand response condition, compared with the full output condition. The area-weighted reduction must be at least 15% but must not reduce the combined illuminance from electric light and daylight to less than 50% of the design illuminance in any individual space.
- Minimum output test
 - Using the manual switches/dimmers in each space, set the lighting system to minimum output (but not off). Note that the lighting in areas with photocontrols or occupancy/vacancy sensors may be at more than minimum output, or may be off.
 - Take one illuminance measurement at each location, using an illuminance meter.
 - Simulate a demand response condition using the demand responsive control.
 - Take one illuminance measurement at each location with the electric lighting system in the demand response condition.
 - In each space, the illuminance in the demand response condition must not be less than the illuminance in the minimum output condition or 50% of the design illuminance, whichever is less.

EXCEPTION: In daylight spaces, the illuminance in the demand response condition may reduce below the minimum output condition, but in the demand response condition the combined illuminance from daylight and electric light must be at least 50% of the design illuminance.

Method 2: Current measurement. Measure the reduction in electrical current in spaces required to meet Section 131(b), as follows:

- At the lighting circuit panel, select at least one lighting circuit that serves spaces required to meet Section 131(b).
- Full output test
 - Using the manual switches/dimmers in each space, set the lighting system to full output. Note that the lighting in areas with photocontrols or occupancy/vacancy sensors may be at less than full output, or may be off.
 - Take one electric current measurement for each selected circuit.

- o Simulate a demand response condition using the demand responsive control.
 - o Take one illuminance measurement at each location with the electric lighting system in the demand response condition.
 - o Add together all the circuit currents, and calculate the reduction in current in the demand response condition, compared with the full output condition. The combined reduction must be at least 15% but must not reduce the output of any individual circuit by more than 50%.
- Minimum output test
 - o Using the manual switches/dimmers in each space, set the lighting system to minimum output (but not off). Note that the lighting in areas with photocontrols or occupancy/vacancy sensors may be at more than minimum output, or may be off.
 - o Take one electric current measurement for each selected circuit.
 - o Simulate a demand response condition using the demand responsive control.
 - o Take one electric current measurement for each selected circuit with the electric lighting system in the demand response condition.
 - o In each space, the electric current in the demand response condition must not be less than 50% or the electric current in the minimum output condition, whichever is less.

EXCEPTION: Circuits that supply power to the daylight portion of enclosed spaces as long as lighting in non-daylit portions of the

Alternate Calculation Method (ACM) Manual

No changes were proposed.

Nonresidential Compliance Manual

5.4 Mandatory Lighting Controls

5.4.5 Demand Responsive Controls.

1. Lighting power in buildings larger than 10,000 square feet shall be capable of being automatically reduced in response to a Demand Responsive Signal; so that the building's total lighting power can be lowered by a minimum of 15 percent below the total installed lighting power. Lighting shall be reduced in a manner consistent with uniform level of illumination requirements in TABLE 5-2 of this manual (Table 130.1-A in the Standards).
2. Spaces that are non-habitable shall not be used to comply with this requirement, and spaces with a sum total lighting power density of less than 0.5 watts per square foot shall not be counted toward the building's total lighting power. Non-habitable spaces are those that are rarely used such as storage closets, unconditioned sheds, etc. Spaces with very low lighting power densities are less likely to have spare lighting capacity to shed during peak demand times.

3. Demand Response Definitions:

- a. *DEMAND RESPONSE is defined as short-term changes in electricity usage by end-use customers, from their normal consumption patterns.*

Demand response may be in response to:

- i. *Changes in the price of electricity; or*
 - ii. *Participation in programs or services designed to modify electricity use in response to wholesale market prices or when system reliability is jeopardized.*
- b. *DEMAND RESPONSE PERIOD is defined as a period of time during which electricity loads are modified in response to a demand response signal.*
- c. *DEMAND RESPONSE SIGNAL is defined as a signal sent by the local utility, Independent System Operator (ISO), or designated curtailment service provider or aggregator, to a customer, indicating a price or a request to modify electricity consumption, for a limited time period.*
- d. *DEMAND RESPONSIVE CONTROL is defined as a kind of control that is capable of receiving and automatically responding to a demand response signal.*

4. Demand responsive controls and equipment

Demand responsive controls and equipment shall be capable of receiving and automatically responding to at least one standard messaging protocol which enables demand response after receiving a demand response signal.

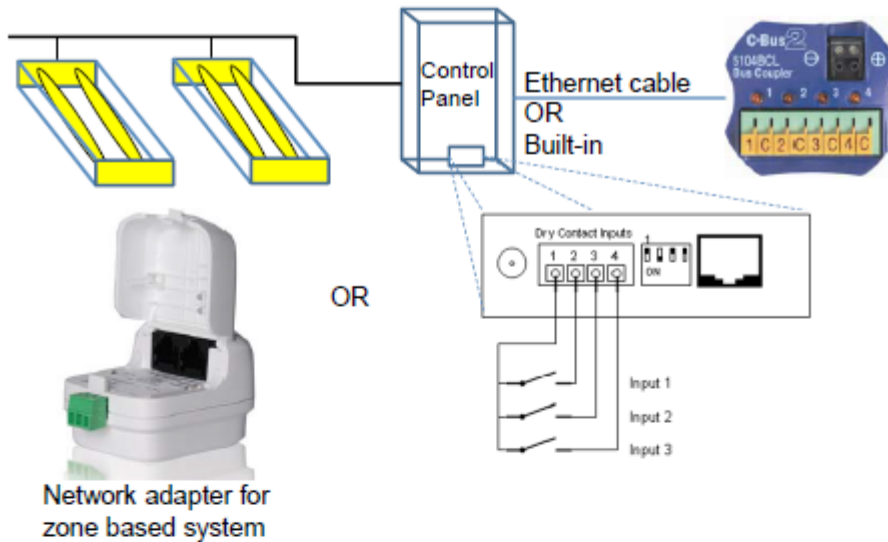

Figure 5-13 - Potential inputs to receive Demand Response signal

Figure 5- this figure illustrates example inputs that could be used to receive demand response signals. The inclusion of one of these types of control inputs, along with the proper design of the lighting system, will result in a lighting system that complies with the requirements of §130.1(e). There are several ways in which the lighting can be designed to meet the demand responsive requirements; outlined below are three specific compliance scenarios.

Example 5-1 Centralized Powerline Dimming Control

This scenario uses a system that has centralized control of dimmable ballasts using a type of powerline carrier signal. This requires no additional wiring as the control signal travels over the existing power line. This can be a very effective means of enabling demand response in small scenarios, such as a small office. This requires the use of a lighting control panel downstream of the breaker panel. The lighting circuit relays are replaced by circuit controllers, which can send the dimming signal via line voltage wires. The panel could have several dry contact inputs that provide dedicated levels of load shed depending upon the demand response signal received. Different channels can be assigned to have different levels of dimming as part of the demand response. Local controls can be provided by either line voltage or low voltage controls.

Example 5-2 Addressable Lighting System

The addressable lighting system is similar in design to that of a centralized control panel, but with additional granularity of control. With an addressable system, each fixture can be addressed individually, whereas a centralized control panel is limited to an entire channel, or circuit, being controlled in unison. The cost of enabling demand response on a system with a centralized control panel is less dependent on building size or number of rooms than a zone based system.

Enabling demand response for the addressable lighting system entails making a dry contact input available to receive an electronic signal. This is a feature that is included in the base model of most lighting control panels. Some smaller scale addressable lighting systems may have a limited number of inputs dedicated for alternative uses, such as a timeclock. If this is the case, an I/O input device can be added to the network to provide an additional closed contact input.

Example 5-3 Demand response for select zones

Enabling demand response for a zoned system would entail adding a network adapter to each room to be controlled for purposes of demand response. The network adapter allows for each room to be monitored and controlled by an energy management control system (EMCS). These types of systems are commonly used for HVAC systems, and to respond to demand response signals. The assumption is that if the building is installing an EMCS, the preference would be to add the lighting network to that existing demand response system. There is additional functionality that results from adding the lighting system to an EMCS. In addition to being able to control the lighting for demand response, the status of the lighting system can then be monitored by the EMCS. For example, occupancy sensors would be able to be used as triggers for the HVAC system, turning A/C on and off when people entered and left the room. Therefore the potential for savings from this type of system is higher than the value of the lighting load shed for demand response.

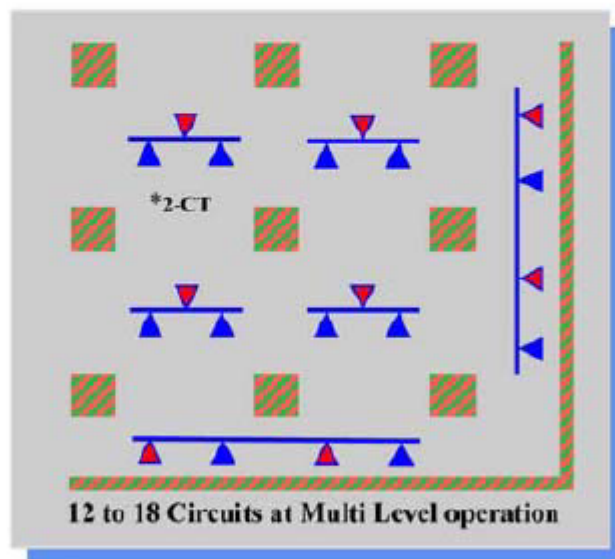

*Note: 2-circuit track used in this scenario

Figure 5-14 – Sample retail DR (demand response) control strategy

Figure 5- illustrates a sample demand response design that maintains uniformity and with a 25 percent power reduction exceeds the 15 percent minimum power reduction requirement. The triangles in this plan are halogen display lighting – the triangles with colored centers are turned off during the DR period. The striped squares are fluorescent troffers and the striped lines are fluorescent wall washers. These fluorescent fixtures are wired for bi-level control so that half of the lamps are turned off during the DR period.

Compliance Forms

These forms were developed anew in their entirety for the 2013 Title 24 Standards.

CERTIFICATE OF ACCEPTANCE		NRCA-ILT-04-A
Demand Responsive Lighting Control Acceptance Document		(Page 1 of 4)
Project Name/Address:		
System Name or Identification/Tag:	System Location or Area Served:	

Enforcement Agency:	Permit Number:
Note: Submit one Certificate of Acceptance for each system that must demonstrate compliance.	Enforcement Agency Use: Checked by/Date

Documentation Author's Declaration Statement	
<ul style="list-style-type: none"> I certify that this Certificate of Acceptance documentation is accurate and complete. 	
Name:	Signature:
Company:	Date:
Address:	If Applicable: <input type="checkbox"/> CEA or <input type="checkbox"/> CEPE (Certification #):
City/State/Zip:	Phone:

FIELD TECHNICIAN'S DECLARATION STATEMENT

- I certify under penalty of perjury, under the laws of the State of California, the information provided on this form is true and correct.
- I am the person who performed the acceptance requirements verification reported on this Certificate of Acceptance (Field Technician).
- I certify that the construction/installation identified on this form complies with the acceptance requirements indicated in the plans and specifications approved by the enforcement agency, and conforms to the applicable acceptance requirements and procedures specified in Reference Nonresidential Appendix NA7.
- I have confirmed that the Installation Certificate(s) for the construction/installation identified on this form has been completed and is posted or made available with the building permit(s) issued for the building.

Company Name:		
Field Technician's Name:		Field Technician's Signature:
Date Signed:	Position With Company (Title):	

RESPONSIBLE PERSON'S DECLARATION STATEMENT

- I certify under penalty of perjury, under the laws of the State of California, that I am the Field Technician, or the Field Technician is acting on my behalf as my employee or my agent and I have reviewed the information provided on this form.
- I am a licensed contractor, architect, or engineer, who is eligible under Division 3 of the Business and Professions Code, in the applicable classification, to take responsibility for the scope of work specified on this document and attest to the declarations in this statement (responsible person).
- I certify that the information provided on this form substantiates that the construction/installation identified on this form complies with the acceptance requirements indicated in the plans and specifications approved by the enforcement agency, and conforms to the applicable acceptance requirements and procedures specified in Reference Nonresidential Appendix NA7.
- I have confirmed that the Installation Certificate(s) for the construction/installation identified on this form has been completed and is posted or made available with the building permit(s) issued for the building.
- I will ensure that a completed, signed copy of this Certificate of Acceptance shall be posted, or made available with the building permit(s) issued for the building, and made available to the enforcement agency for all applicable inspections. I understand that a signed copy of this Certificate of Acceptance is required to be included with the documentation the builder provides to the building owner at occupancy.

Company Name:		Phone:
Responsible Person's Name:		Responsible Person's Signature:
License #:	Date Signed:	Position With Company (Title):

CERTIFICATE OF ACCEPTANCE		NRCA-ILT-04-A
Demand Responsive Lighting Control Acceptance Document		(Page 2 of 4)
Project Name/Address:		
System Name or Identification/Tag:	System Location or Area Served:	

Demand Responsive Lighting Control	
Intent:	Test the reduction in lighting power due to the demand responsive lighting control as per Sections 110.9(a), 130.1(e) and 130.5(e).
NA7.6.7 Acceptance tests for Demand Responsive Lighting Controls in accordance with Section 130.1(e)	
1	Instrumentation to perform test includes, but not limited to:
	a. Hand-held amperage and voltage meter
	b. Power meter
	c. Light meter
continued on next page	

2	Construction Inspection	
	<input type="checkbox"/>	Verify the demand responsive control is capable of receiving a demand response signal directly or indirectly through another device and that it complies with the requirements in Section 130.5(e).
	130.5(e)	Demand responsive controls and equipment shall be capable of receiving and automatically responding to at least one standards based messaging protocol which enables demand response after receiving a demand response signal.
	Definition	DEMAND RESPONSE SIGNAL is a signal sent by the local utility, Independent System Operator (ISO), or designated curtailment service provider or aggregator, to a customer, indicating a price or a request to modify electricity consumption, for a limited time period.
	<input type="checkbox"/>	If the demand response signal is received from another device (such as an EMCs), that system must itself be capable of receiving a demand response signal from a utility meter or other external source.

NA7.6.7.2 Functional Test		
<input type="checkbox"/>	1	Use either Method 1 (illuminance measurement) or Method 2 (power input measurement) to perform the functional test.
<input type="checkbox"/>	2	Test building-wide reduction in lighting power to at least 15% below the maximum total lighting power, as calculated on an area-weighted basis (measured in illuminance or power). However, any single space must not reduce the combined illuminance from daylight and electric light to less than 50% of the design illuminance.
<input type="checkbox"/>	3	For buildings with up to seven (7) enclosed spaces requiring demand responsive lighting controls, all spaces shall be tested.
<input type="checkbox"/>	4	For buildings with more than seven (7) enclosed spaces requiring demand responsive lighting controls, sampling may be done on additional spaces with similar lighting systems. If the first enclosed space with a demand responsive lighting control in the sample group passes the acceptance test, the remaining building spaces in the sample group also pass. If the first enclosed space with a demand responsive lighting control in the sample group fails the acceptance test the rest of the enclosed spaces in that group must be tested.
<input type="checkbox"/>	5	If any tested demand responsive lighting control system fails it shall be repaired, replaced or adjusted until it passes the test.

Method 1: Illuminance Measurement.
 In each space, select one location for illuminance measurement. The chosen location must not be in a primary or secondary skylit or sidelit area, and when placed at the location, the illuminance meter must not have a direct view of a window or skylight. If this is not possible, perform the test at a time and location at which daylight illuminance provides less than half of the design illuminance. Mark each location to ensure that the illuminance meter can be accurately located.

Step 1: Full output test		Space number						
		1	2	3	4	5	6	7
a.	Using the manual switches/dimmers in each space, set the lighting system to full output. Note that the lighting in areas with photocontrols or occupancy/vacancy sensors may be at less than full output, or may be off.							
b.	Take one illuminance measurement at a representative location in each space, using an illuminance meter.	fc	fc	fc	fc	fc	fc	fc

Project Name/Address:

System Name or Identification/Tag:	System Location or Area Served:
------------------------------------	---------------------------------

c.	Simulate a demand response condition using the demand responsive control.							
d.	Take one illuminance measurement at the same locations as above, with the electric lighting system in the demand response condition.	fc	fc	fc	fc	fc	fc	fc
e.	Calculate the reduction in illuminance in the demand response condition, compared with the full output condition. [(b-d)/b]	%	%	%	%	%	%	%
f.	Note the area of each controlled space	sf	sf	sf	sf	sf	sf	sf
g.	The area-weighted reduction must be at least 15% but must not reduce the combined illuminance from electric light and daylight to less than 50% of the design illuminance in any individual space.	$1 - \frac{[(e1 \times f1) + (e2 \times f2) + (e3 \times f3) \dots]}{[f1 + f2 + f3 \dots]}$ Y / N						
h.	The demand response signal must not reduce the power input of any individual circuit by more than 50%.	Y / N	Y / N	Y / N	Y / N	Y / N	Y / N	Y / N

continued on next page

Step 2: Minimum output test

a.	Using the manual switches/dimmers in each space, set the lighting system to minimum output (but not off). Note that the lighting in areas with photocontrols or occupancy/vacancy sensors may be at more than minimum output, or may be off.							
b.	Take one illuminance measurement at each location, using an illuminance meter.	fc	fc	fc	fc	fc	fc	fc
c.	Simulate a demand response condition using the demand responsive control.							
d.	Take one illuminance measurement at each location with the electric lighting system in the demand response condition.	fc	fc	fc	fc	fc	fc	fc
e.	In each space, the illuminance in the demand response condition must not be less than the illuminance in the minimum output condition or 50% of the design illuminance, whichever is less.	Y / N	Y / N	Y / N	Y / N	Y / N	Y / N	Y / N

EXCEPTION: In daylight spaces, the illuminance in the demand response condition may be below the minimum output setting, but in the demand response condition the combined illuminance from daylight and electric light must be at least 50% of the design illuminance.

Method 2: Power Input Measurement.

At the lighting circuit panel, select at least one lighting circuit that serves spaces required to meet Section 130.1(b) to measure the reduction in electrical current. Alternatively, employ the power monitoring capabilities of the DR controls system to monitor the circuits in the tests below. The testing process is constant with either approach.

		Circuit number						
Step 1: Full output test		1	2	3	4	5	6	7
a.	Using the manual switches/dimmers in each space, set the lighting system to full output. Note that the lighting in areas with photocontrols or occupancy/vacancy sensors may be at less than full output, or may be off.							

Project Name/Address:

System Name or Identification/Tag:	System Location or Area Served:
------------------------------------	---------------------------------

b.	Take one electric power measurement for each selected circuit.	VA	VA	VA	VA	VA	VA	VA
c.	Simulate a demand response condition using the demand responsive control.							
d.	Take one electric power measurement at each circuit location with the electric lighting system in the demand response condition.	VA	VA	VA	VA	VA	VA	VA
e.	Calculate the reduction in lighting power in the demand response condition, compared with the full output condition [(b-d)/b]	%	%	%	%	%	%	%
f.	Note the area of each controlled space	sf	sf	sf	sf	sf	sf	sf
g.	Calculate the area-weighted average reduction in electric power in the demand response condition, compared with the full output condition. The area-weighted reduction must be at least 15%	$1 - \frac{[(e1 \times f1) + (e2 \times f2) + (e3 \times f3) \dots] [f1 + f2 + f3 \dots]}{Y / N}$						
h.	The demand response signal must not reduce the power input of any individual circuit by more than 50%.	Y / N	Y / N	Y / N	Y / N	Y / N	Y / N	Y / N

Step 2: Minimum output test

a.	Using the manual switches/dimmers in each space, set the lighting system to minimum output (but not off). Note that the lighting in areas with photocontrols or occupancy/vacancy sensors may be at more than minimum output, or may be off.							
----	--	--	--	--	--	--	--	--

continued on next page

b.	Take one electric power measurement for each selected circuit location.	VA	VA	VA	VA	VA	VA	VA
c.	Simulate a demand response condition using the demand responsive control.							
d.	Take one electric power measurement at each circuit with the electric lighting system in the demand response condition.	VA	VA	VA	VA	VA	VA	VA
e.	In each space, the electric power input in the demand response condition must not be less than the power input in the minimum light output condition or 50% of the design illuminance power input condition, whichever is less.	Y / N	Y / N	Y / N	Y / N	Y / N	Y / N	Y / N

EXCEPTION: Circuits that supply power to the daylit portion of enclosed spaces as long as lighting in non-daylit portions of the space are not reduced below the lesser of 50% power input level or the minimum light output condition.

C.	Evaluation :
<input type="checkbox"/>	PASS: All applicable Construction Inspection responses are complete and all applicable Equipment Testing Requirements responses are positive (Y - yes)

Energy Savings Estimates

Demand Responsive lighting controls is an enabling technology measure and does not inherently require that building occupants participate in DR events. To estimate the energy impact of this measure, probability rates that affect usage of DR technology was obtained from previous utility DR programs. It is assumed that 70 percent of occupants will enroll, or remain enrolled, in utility DR programs (taking into account the default electric utility rate for commercial customers is expected to involved peak load shifting incentives when the 2013 building energy efficiency standards takes effect). To account for technical difficulties or service disruption, it is assumed that 97 percent of DR signals sent to enrolled users will be successfully received. After receiving the signal, it is assumed that 10 percent of enrolled users will override the automatic reduction, and that the remaining participants will shed 15 percent of their lighting load. Adjusting the lighting load that will be shed according to these assumptions, it is concluded that, during a DR event, the statewide commercial lighting load will be reduced by 9.2 percent.

To determine the number of DR event hours, the IOU C&S team took the top 1% of hourly TDV values for each climate zone. The hours were then factored to only include weekdays between 8am to 7pm, which results in a total of 88 hours per year applicable for DR events.

Using the assumptions listed above and the allowed Lighting Power Densities (LPDs) for building types, the IOU C&S team calculated the savings per square foot of building type in each climate zone shown below in Figure 1. These values were then applied to the forecasted new construction data for each building type obtained from the CEC. The 2003 Commercial Building Energy Consumption Survey provided data on the percent of floor space of each building type greater than 10,000 square feet. The produced the statewide average savings value of \$0.12 per square foot weighted by building type and climate zone.

Figure 1 Statewide Savings (\$/sf) from DR Lighting by Climate Zone and Building Type

	Office	Retail	Warehouse	Refrigerated Warehouse	Grocery Store	Hotel	Restaurant	Schools	Average Savings Weighted by Building Types
CZ1 (\$/sf)	\$0.14	\$0.07	\$0.07	\$0.14	\$0.09	\$0.12	\$0.10	\$0.11	\$0.11
CZ2 (\$/sf)	\$0.19	\$0.09	\$0.10	\$0.19	\$0.12	\$0.17	\$0.14	\$0.14	\$0.14
CZ3 (\$/sf)	\$0.19	\$0.09	\$0.10	\$0.19	\$0.12	\$0.17	\$0.14	\$0.15	\$0.15
CZ4 (\$/sf)	\$0.18	\$0.09	\$0.09	\$0.18	\$0.12	\$0.16	\$0.13	\$0.14	\$0.14
CZ5 (\$/sf)	\$0.14	\$0.07	\$0.07	\$0.14	\$0.09	\$0.12	\$0.11	\$0.11	\$0.11
CZ6 (\$/sf)	\$0.20	\$0.10	\$0.10	\$0.20	\$0.13	\$0.18	\$0.15	\$0.15	\$0.15
CZ7 (\$/sf)	\$0.18	\$0.09	\$0.09	\$0.18	\$0.12	\$0.16	\$0.14	\$0.14	\$0.14
CZ8 (\$/sf)	\$0.16	\$0.08	\$0.08	\$0.16	\$0.10	\$0.14	\$0.12	\$0.12	\$0.12
CZ9 (\$/sf)	\$0.22	\$0.11	\$0.11	\$0.22	\$0.14	\$0.19	\$0.16	\$0.17	\$0.17
CZ10 (\$/sf)	\$0.19	\$0.09	\$0.10	\$0.19	\$0.12	\$0.17	\$0.14	\$0.15	\$0.15
CZ11 (\$/sf)	\$0.20	\$0.10	\$0.10	\$0.20	\$0.13	\$0.18	\$0.15	\$0.16	\$0.16
CZ12 (\$/sf)	\$0.18	\$0.09	\$0.09	\$0.18	\$0.12	\$0.16	\$0.14	\$0.14	\$0.14
CZ13 (\$/sf)	\$0.15	\$0.07	\$0.08	\$0.15	\$0.10	\$0.13	\$0.11	\$0.11	\$0.11
CZ14 (\$/sf)	\$0.14	\$0.07	\$0.07	\$0.14	\$0.09	\$0.12	\$0.11	\$0.11	\$0.11
CZ15 (\$/sf)	\$0.13	\$0.06	\$0.07	\$0.13	\$0.08	\$0.12	\$0.10	\$0.10	\$0.10
CZ16 (\$/sf)	\$0.19	\$0.09	\$0.09	\$0.19	\$0.12	\$0.16	\$0.14	\$0.14	\$0.14
Average Savings Weighted by Climate Zones (\$/sf)	\$0.17	\$0.08	\$0.09	\$0.17	\$0.11	\$0.15	\$0.13	\$0.12	\$0.12

The demand savings were calculated using two separate methods; first, the CEC methodology and then the CPUC methodology. The CEC methodology selects 250 specific hours deemed as peak, and then assigns allocation factors for savings to each of these hours. The CPUC methodology calculates the average savings over the peak period defined as weekdays from 12pm to 6pm between July and September. The value below will present savings based on CEC methodology; however, the CPUC statewide demand savings are calculated to be 1.42 MW annually.

Statewide impacts from this measure are presented in **Error! Reference source not found..** Cumulative energy impacts are calculated based on the measure life (either 15 or 30 years). Cumulative energy savings (GWh) account for the first year impacts in 2014, plus double that savings the next year due another crop of new installations saving energy in addition to the previous year’s installations, then triple the savings in the third year and so on. Cumulative gas energy savings and GHG emissions avoided are calculated the same way. The cumulative demand savings only account for the reduction in demand from the first year of installation for each year’s new construction (thus calculated as the first year demand savings multiplied by the number of years of new installations).

Table 2. Statewide Impacts for Demand Responsive Lighting Controls

	Electric Demand (MW)	Electric Energy (GWh)	Gas Energy (MMTherms)	GHG Emissions Avoided (MTons CO₂eq)^[2]
First Year Impacts	3.25	0.779	n/a	0.340
Cumulative Impacts (over 15 Years)	48.75	93.5	n/a	40.9

As a result of the first year of construction (2014) under the new requirements of the Demand Responsive Lighting Controls measure, statewide TDV energy savings are estimated at 160,106,034 kBtu with a net present value of \$12,749,019, using 15-year nonresidential TDV values.

Acknowledgments

The Pacific Gas and Electric Company, Southern California Edison, Southern California Gas Company and San Diego Gas and Electric Company sponsored this report as part of the CASE (Codes and Standards Enhancement) project for the 2013 Building Energy Efficiency Standards. Stuart Tartaglia of PG&E was the project manager for this CASE project; Patrick Eilert is the program manager for the PG&E CASE program. Randall Higa is the program manager for the SCE CASE program. Ron Gorman was the program manager on behalf of the Southern California Gas Company and the San Diego Gas and Electric Company. The Heschong Mahone Group, a TRC company (HMG) and Energy Solutions are the prime contractors and provided coordination of the residential and nonresidential CASE reports.

Joshua Rasin of HMG performed the analysis and reporting presented here, with technical and editorial review by additional staff at HMG.

We would like to thank the many reviewers that volunteered their time and effort to improving this proposal. We would particularly like to thank Gary Flamm and Owen Howlett of the CEC, Jon McHugh of McHugh Energy, and the numerous lighting manufacturers who took the time to provide information crucial to the development of this code requirement

^[2] At 0.437 MTCO₂e/GWh, and 5.32 MTCO₂e /MMTherm. Source: AB 32 Scoping Plan Appendix G: Economic Analysis; page I-16: emission factor for grid power. Available online at: http://www.arb.ca.gov/cc/scopingplan/document/appendices_volume2.pdf

Appendix Preliminary CASE Report

Nonresidential Demand Responsive Lighting Controls

2013 California Building Energy Efficiency Standards

California Utilities Statewide Codes and Standards Team

October 2011



This report was prepared by the California Statewide Utility Codes and Standards Program and funded by the California utility customers under the auspices of the California Public Utilities Commission.

Copyright 2011 Pacific Gas and Electric Company, Southern California Edison, SoCalGas, SDG&E.

All rights reserved, except that this document may be used, copied, and distributed without modification.

Neither PG&E, SCE, SoCalGas, SDG&E, nor any of its employees makes any warranty, express of implied; or assumes any legal liability or responsibility for the accuracy, completeness or usefulness of any data, information, method, product, policy or process disclosed in this document; or represents that its use will not infringe any privately-owned rights including, but not limited to, patents, trademarks or copyrights

Nonresidential Demand Responsive Lighting Controls

2013 California Building Energy Efficiency Standards

California Utilities Statewide Codes and Standards Team

September 2011

CONTENTS

- 1. Overview.....5**
- 2. Methodology..... 12**
 - 2.1 Data Collection 12
 - 2.1.1 Review of Market Assessment and Program Evaluation Literature..... 13
 - 2.1.2 Interviews..... 13
 - 2.2 Development of Prototype Buildings 14
 - 2.3 Compliance Scenarios 16
 - 2.4 Savings Analysis Methodology 17
 - 2.5 Cost Analysis Methodology 18
 - 2.6 Lifecycle Cost (LCC) Analysis 20
 - 2.7 Cost Effectiveness Analysis 20
 - 2.8 Statewide Savings Estimates 21
 - 2.9 Stakeholder Meeting Process..... 21
- 3. Analysis and Results..... 22**
 - 3.1 Review of Market Assessment and Program Evaluation Literature..... 22
 - 3.2 Compliance scenarios 23
 - 3.2.1 Strategy A: Bi-Level Wiring..... 24
 - 3.2.2 Strategy B: Addressable lighting system 25
 - 3.2.3 Strategy C: Centralized Powerline Dimming Control 25
 - 3.2.4 Strategy D: Digital Zone Based System 26
 - 3.3 Savings Analysis 26
 - 3.4 Cost Analysis..... 31
 - 3.5 Cost Effectiveness Analysis 36

3.6 Statewide Demand Response Savings.....39

4. Recommended Language for the Standards Document, ACM Manuals, and the Reference Appendices 41

4.1.1 Section 101(b) Definitions.....41

4.1.2 Section ~~131(e)~~130.1(e).....41

4.1.3 TABLE 146-C LIGHTING POWER ADJUSTMENT FACTORS43

4.1.4 NA7.6.5 Demand Responsive Lighting Controls Acceptance.....44

5. Bibliography and Other Research47

6. Appendix A--Prototype Building Layouts 49

7. Appendix B—Controllable Lighting Technology and Products..... 52

8. Appendix C -- Non-Residential Construction Forecast details54

8.1 Summary.....54

8.2 Additional Details.....54

8.3 Citation55

FIGURES

Figure 1 Statewide Savings Estimate..... 7

Figure 2 Description of Prototype Office Buildings Used for Analysis..... 14

Figure 3 Breakdown of Spaces in Prototype Buildings 16

Figure 4 Area Category LPD allowance for Office Spaces..... 17

Figure 5 Title 24 Table 146-E Complete Building Method LPD Values (Watts/sf) 19

Figure 6 Hourly TDV Values Triggering Demand Response 27

Figure 7 Assumptions for demand responsive lighting load shed 28

Figure 8 Lighting Power Density and Adjusted Load Shed by Building Type 29

Figure 9 Statewide Savings (\$/sf) from DR Lighting by Climate Zone and Building Type 30

Figure 10 Costs associated with various demand response enabling strategies 32

Figure 11 Cost Effectiveness of DR in Small Office Prototype 37

Figure 12 Cost Effectiveness of DR in Large Office Prototype 38

Figure 13 Statewide Annual Energy and Demand Savings 40

Figure 14 Small office prototype building reflected ceiling and floor plan 49

Figure 15 West Wing of Large Office Prototype Floor Plan..... 50
Figure 16 East Wing of Large Office Prototype Floor Plan 51
Figure 17 Diagram of third party Auto-DR module inputs and outputs..... 53

1. Overview

a. Measure Title	Nonresidential Demand Responsive Lighting Controls
b. Description	<p>This report investigates the feasibility and cost-effectiveness of requiring automated demand responsive controls on commercial indoor lighting loads. This demand responsive control would enable users to control their electricity costs during highest cost periods by automatically reducing their lighting electricity consumption upon receipt of a demand response signal (a signal sent by the local utility or Independent System Operator (ISO) indicating a price or a request to their customers to curtail electricity consumption).</p> <p>This measure ensures that new commercial facilities include the technical capability to easily join automated DR programs in the future using nationally recognized open communication standards.</p> <p>The scope of this measure is to make all lighting loads that will have multiple levels of control (as required by the Controllable Lighting CASE) also be capable of being controlled for purposes of demand response. If the Controllable Lighting Requirements are not adopted, it is recommended that DR be required in commercial buildings larger than 10,000 square feet, excluding residential common areas, areas with automatic daylighting controls, or any space with an LPD less than or equal to 0.5 W/sf. In that scenario the demand responsive lighting controls must be capable of temporarily limiting lighting power to no more than 85% of permanently installed lighting power of the enclosed space. If general lighting is reduced, it must be done so in accordance with Section 131(b). This can be accomplished with the use of relays and additional wire to control branches of bi level lighting.</p>
c. Type of Change	Requirement for demand responsive lighting controls would be mandatory for occupancies and sizes of buildings where they are most cost-effective. As a mandatory measure, these controls do not affect the performance method and they are not involved in trade-off calculations. These controls, like most of the other automated lighting controls in the standards, would require an acceptance test to assure they are working correctly at time of installation.
d. Energy Benefits	<p>As described in Section 3 - Analysis and Results, the proposed code change would save approximately 20% of the installed lighting load. In offices, the whole building LPD of 0.8 W/sf would allow for savings 0.14 W/sf for each hour of a demand response event (88 annually). This amounts to a 15-year TDV value of \$0.19/sf.</p> <p>The proposed change will not significantly affect natural gas use. There is precedent for ignoring the interactive effects (i.e., that less lighting will reduce internal gains, thereby increasing heating and decreasing cooling needs) for the IOU lighting programs. This precedent is followed here, particularly because the savings will</p>

occur in short time spans, from a small reduction in lighting load. Additionally, demand response events are more likely to take place during the cooling season in California, rather than during the heating season.

These energy savings are based on the following assumptions: We assume that customers will be on a time of use rate with peak day pricing (critical peak pricing) by default, and that 30% of customers will opt-out of such a rate. We assume that customers are price responsive to the top 1% of hours, and therefore will treat 88 hours of the year as demand response periods. We assume that customers will shed 20% of their lighting load during each demand response period, and that 10% of customers will override the automatic load shed during each demand response period. Detailed calculations are available in the Section 3 - [Analysis and Results](#). The savings as calculated for the office prototypes are presented in the table below. Demand Savings is calculated as the average demand savings for the Peak Period as defined by the CPUC for calculating program savings; which includes all weekday hours between 12pm and 6pm for July through September.

	Electricity Savings (kwh/yr)	Demand Savings (kw)	Natural Gas Savings (Therms/yr)	TDV Electricity Savings	TDV Gas Savings
Per Unit Measure ¹	N/A	N/A	N/A	N/A	N/A
Per Small Office Prototype ² (8,200 sf)	110	0.2	N/A	\$1,774	N/A
Per Large Office Prototype ² (34,000 sf)	460	0.8	N/A	\$7,382	N/A
Savings per square foot ³	0.0135	0.00002	N/A	\$0.22/sf	N/A

1. Specify the type of unit such as per lamp, per luminaire, per chiller, etc.
2. For description of prototype buildings refer to Methodology section below.
3. Applies to nonresidential buildings only.

Statewide Savings Estimate:

The expected statewide first year savings from the proposed UST measure are presented below in [Figure 1](#). More detail about how these estimates were developed is contained in Section 3.6.

	First Year Electric Energy Savings (GWh)	First Year Peak Demand Savings (MW)	First Year Gas Energy Savings (MMtherms)	First Year TDV Energy Savings (kBTU)
Total Statewide	0.883	3.68	n/a	160,106,034

Figure 1 Statewide Savings Estimate

e. Non-Energy Benefits

The ability to manage daily peak loads provides the potential to reduce end user electricity bills by limiting the monthly peak demand. The rollout of dynamic pricing by the California Utilities over the next several years increases the economic value of customers being able to actively manage their lighting energy consumption.

Businesses participating in the demand response program should see increased property values because they have reduced the operating cost of the buildings they own or lease. This can potentially make their property more attractive to future tenants or buyers since there could be a lower cost of operation.

Reducing power consumption will reduce the use of the fuels that produce the needed electricity resulting in a positive statewide impact on power plant emissions. Air quality will improve reducing related illnesses and improving community health in general, which in turn should have an impact on the demand for health care services. The economic side benefit that results from cleaner air is increased commerce (productivity), which benefits everyone. Productivity is also increased because business will be able to remain open during times when they may have been inadvertently shut down by a blackout. This also reduces the amount of land and resources that must be dedicated to a larger electricity infrastructure. (PG&E 2007).

f. Environmental Impact

To implement demand responsive lighting controls, additional wiring and additional lighting contactors may be required. Thus slightly more copper and plastic would be used in indoor wiring systems. The benefits of this measure are a reduction in the number of power plants needed and a reduction in the size of the transmission and distributions system. This reduces the amount of land and resources that must be dedicated to a larger electricity infrastructure. The emissions impacts of this measure are calculated by multiplying the change in statewide electricity and natural gas consumption by the hourly emissions factors. In many scenarios, there will be no additional materials required to comply with the requirement for demand response capabilities, since enabling demand response can be as simple as connecting a lighting control panel to the internet via Ethernet. However in some situations the addition of a DR module will be required to connect to the lighting control panel via the dry contact input. We are using a worst-case scenario and assuming that every building

will need to install a 1-pound AutoDR module that controls the lighting panel via dry-contact inputs. In the table below, each unit will be one of these AutoDR modules, and will assume that one is required per building. The module complies with the RoHS directive¹ which limits the amount of mercury or lead to 1,000ppm for any single component of the module. The increased use of silicon and gold for the circuitry in the module is estimated in the table below, at approximately 1oz of silicon, and about 0.1 grams of gold for gold-plated pins. The casing is comprised mostly of plastic with steel screws, thus the estimates of 6oz of steel and 5oz of plastic.

Material Increase (I), Decrease (D), or No Change (NC): (All units are lbs/year)

	Mercury	Lead	Copper	Steel	Plastic	Others (Identify)
Per Unit Measure ¹	(I) 0.001	(I) 0.001	(I) 0.25	(I) 0.375	(I) 0.3125	Silicon - (I) 0.0625 Gold - (I) 0.0002

Specify the type of unit such as per lamp, per luminaire, per chiller, etc.

1. Each unit is one demand response module. It is assumed that worst case scenario is one DR module per building.
2. For description of prototype buildings refer to Methodology section below.

Water Consumption:

	On-Site (Not at the Powerplant) Water Savings (or Increase) (Gallons/Year)
Per Unit Measure ¹	N/A
Per Prototype Building ²	NC

1. Specify the type of unit such as per lamp, per luminaire, per chiller, etc.
2. For description of prototype buildings refer to Methodology section below.

Water Quality Impacts:

Comment on the potential increase (I), decrease (D), or no change (NC) in contamination compared to the basecase assumption, including but not limited to: mineralization (calcium, boron, and salts), algae or bacterial buildup, and corrosives as a result of PH change.

	Mineralization (calcium, boron, and salts)	Algae or Bacterial Buildup	Corrosives as a Result of PH Change	Others

¹ [The Restriction of Hazardous Substances \(RoHS\) Directive was adopted in 2003 by the European Union, and limits the maximum concentrations of various chemicals, including lead and mercury, to no more than 0.1% or 1,000 ppm by weight of homogenous material.](#)

Impact (I, D, or NC)	NC	NC	NC	NC
Comment on reasons for your impact assessment				
g. Technology Measures	<p>Measure Availability:</p> <p>This measure both requires and encourages the use of lighting control technology as it relates to controlling the consumption of energy on a 24-hour basis and at peak periods. This measure addresses a philosophy of design more than the use of existing new technology. The measure will recommend the use of currently available and tested systems coupled with different and more effective building wiring plans to allow for tiered circuiting in place of zone circuiting. This technology could be as simple as a contact closure or could be a more complex digital interface. Once this interface is translated into something like a contact closure, there are already many lighting controls that can make use of this signal and dim or turn lights off in response. Lighting contactors and relays have existed for decades, are available from many different manufacturers, and are reliable. This measure is compatible with newer lighting control technologies such as digital addressable lighting, powerline dimming control, zone based lighting control strategies, wireless mesh etc but does not require the use of these technologies. The lighting control system needs to be able to at least receive and respond to demand response directly or via another system (including an energy management control system). This can as simple as receiving dry contact inputs to indicate a DR event.</p> <p>Useful Life, Persistence, and Maintenance:</p> <p>To achieve the potential savings from demand responsive lighting controls, customers would need to voluntarily participate in a demand response program.</p>			
h. Performance Verification of the Proposed Measure	<p>Verification of installation and performance can be included in the currently established permitting and site inspection process. Annual performance verification will be done by the utilities remotely. In a demand response environment, the utility will have the capability of testing system reliability through live field tests at specified intervals.</p>			

i. Cost Effectiveness

Show the proposed change is cost effective using life cycle costing (LCC) methodology for the prototype building(s) where the measure is installed. Use the Energy Commission Life Cycle Costing Methodology posted on the 2013 Standards website and state the additional first and maintenance costs, the measure life, energy cost savings, and other parameters required for LCC analysis. Use the following table to show the assumptions used to derive the LCC analysis:

a	b	c		d		e		f	g	
		Per sq. ft.	Per Proto Building	Per sq. ft.	Per Proto Building	Per sq. ft.	Per Proto Building		(c+e)-f Based on Current Costs	(d+e)-f Based on Post-Adoption Costs
Measure Name – Demand Responsive Lighting Controls	Measure Life (Years)	Additional Costs ¹ – Current Measure Costs (Relative to Basecase) (\$)		Additional Cost ² – Post-Adoption Measure Costs (Relative to Basecase) (\$)		PV of Additional ³ Maintenance Costs (Savings) (Relative to Basecase) (PV\$)		PV of ⁴ Energy Cost Savings – Per Proto Building (PV\$)	LCC Per Prototype Building (\$)	
Small Office (8,200sf) – Addressable Lighting	15	\$0.24	\$2,008	N/A	N/A	N/A	N/A	\$1,774	\$234	\$(1,774)
Small Office (8,200sf)– powerline dimming	15	\$0.20	\$1,622	N/A	N/A	N/A	N/A	\$1,774	\$(152)	\$(1,774)
Small Office (8,200sf)– zone-based system	15	\$0.70	\$5,821	N/A	N/A	N/A	N/A	\$1,774	\$4,047	\$(1,774)
Large Office (34,000sf)– Addressable Lighting	15	\$0.13	\$4,275	N/A	N/A	N/A	N/A	\$7,382	\$(3,107)	\$(7,382)
Large Office (34,000sf)– powerline dimming	15	\$0.10	\$3,545	N/A	N/A	N/A	N/A	\$7,382	\$(3,837)	\$(7,382)
Large Office (34,000sf)– zone-based system	15	\$0.47	\$16,085	N/A	N/A	N/A	N/A	\$7,382	\$8,703	\$(7,382)
j. Analysis Tools	This measure is proposed as mandatory and will not require the use of analysis tools, because the measure is not subject to whole building trade-offs									

<p>k. Relationship to Other Measures</p>	<p>Identify any other measures that are impacted by this change. Explain the nature of the relationship.</p> <p>Controllable Lighting</p> <p>This proposed measure modifies the minimum requirements in Section 131 for multi-level lighting controls in non-residential buildings. The measure requires additional control steps beyond the existing requirements, specified according to light source. The measure also reduces the maximum lighting power density that is exempt from multi-level control.</p> <p>Daylighting</p> <p>This proposed measure reduces the threshold daylit area that triggers the requirement for photocontrols. Daylight harvesting could reduce the daytime lighting load as more spaces rely on daylight for general lighting. This could reduce the peak lighting load that would be available for demand responsive load shed.</p>
--	---

2. Methodology

This section describes the methodology that we followed to assess the savings, cost, and cost effectiveness of the proposed code change. The key elements of the methodology are as follows:

- ◆ Data Collection
- ◆ Development of Prototype Space Models
- ◆ Development of Compliance Scenarios
- ◆ Savings Analysis
- ◆ Cost Analysis
- ◆ Cost Effectiveness Analysis

This work was publicly vetted through our stakeholder outreach process, which through in-person meetings, webinars, email correspondence and phone calls, requested and received feedback on the direction of the proposed changes. The stakeholder meeting process is described at the end of the Methodology section.

2.1 Data Collection

HMG conducted a review of literature pertaining to the demand responsive lighting market. The purpose of the literature review was to gather supporting data to characterize the following aspects of the DR lighting market, to estimate the savings from the proposed measures, and to inform a discussion among the utilities and lighting stakeholders about the proposed code changes.

- ◆ The major types of Demand Response programs offered to customers
- ◆ Participation rates of customers in DR programs
- ◆ Load shed potential from lighting
- ◆ Technologies enabling load shed of lighting

The DR Lighting CASE team worked with members of the Controllable Lighting CASE team and manufacturers of lighting controls to obtain cost information and design scenarios that would enable demand response and remain compliant with the lighting controls required in Title 24, Part 6, Section 131. The Controllable Lighting CASE team is concurrently proposing requirements increasing the granularity of control required by Section 131(b). A dimmable lighting system is the most likely

method of meeting the Controllable Lighting proposed requirements, therefore research and discussions about scenarios under their proposed requirements focus on dimming systems.²

2.1.1 Review of Market Assessment and Program Evaluation Literature

As part of the literature review, information was collected about the current Investor Owned Utilities (IOU) DR program rates, specifically those related to dynamic pricing. The assumption underlying this code change proposal is that by 2012 customers will be enrolled in a time-of-use (TOU) utility pricing structure that has additional peak charges for hours that occur on days that the utility has identified as a peak day. According to documents filed by the California Public Utilities Commission (CPUC), commercial customers with interval smart meters are placed on the TOU rate structure by default³. All new IOU customers receive smart meters. To determine how commercial customers may respond to a dynamic price rate, we researched existing rate-based demand response programs for the commercial sector.

A complete list of documents reviewed is available in Section 4.1.4 - Bibliography and other research. Highlights of the review are included in Section 3.1.

2.1.2 Interviews

To develop the strategies for meeting the DR lighting controls requirement, we interviewed several major manufacturers of lighting control products and conducted detailed cost analysis of the equipment and labor that would be required to install their systems in each of the prototype buildings. Manufacturers were identified that offered products that enabled centralized control of the dimming lighting systems. Interviews were conducted via a series of phone calls and emails, and on occasion demonstration of the equipment in person. Manufacturers contacted include:

- ◆ Acuity Brands Controls (LC&D)
- ◆ Adura Technologies
- ◆ Convergence Wireless, Inc
- ◆ Douglas Lighting Controls
- ◆ Lumenergi
- ◆ Lutron
- ◆ Schneider-Electric
- ◆ Universal Lighting Technologies

² Throughout the remainder of this document, the term Controllable Lighting will be used to describe lighting systems meeting the requirements being proposed in the concurrent Requirements for Controllable Lighting CASE effort. To comply with this proposal, lighting applications will be required to employ ballast or driver technologies that increase granularity of lighting control at the level of the individual luminaire.

³ http://docs.cpuc.ca.gov/PUBLISHED/NEWS_RELEASE/114096.htm

- ◆ Wattstopper

2.2 Development of Prototype Buildings

To assess the energy savings, cost, and cost effectiveness of the proposed requirement, we developed prototypes of a small office building and a large office building. Lighting power densities (LPDs) for the building are assumed to be the LPDs being proposed for 2013 Title 24 in a separate, concurrent CASE report – Indoor Lighting Controls. These values are essentially the same as the 2008 Title 24 code, but with a slightly lower allowance for open office areas (0.8W/sf instead of 0.9W/sf). [Figure 2](#) shows the basic characteristics of the small and large office prototypes.

	Occupancy Type (Residential, Retail, Office, etc)	Area (Square Feet)	Number of Stories	Other Notes
Prototype 1	Small Office	8,200	1	Rectangular in shape, consists of several open office areas and one- and two-person offices linked by corridors
Prototype 2	Large Office	34,000	1	Rectangular in shape, consists of a core surrounded by a large concentric open office area, with some perimeter private offices.

Figure 2 Description of Prototype Office Buildings Used for Analysis

We chose these office buildings as prototypes because offices are the most common and complex type of buildings in which to implement demand responsive lighting controls. This is because offices are often subdivided into many spaces, have complex routing for wiring, and are already required to install several other lighting control strategies. Offices also have a relatively low allowed lighting power densities (LPDs), reducing the potential savings from demand response (DR) as opposed to other building types with higher LPDs, such as retail. Therefore, the measure cost effectiveness calculated for offices is likely to be at least as high (per square foot) as for other building types. We chose two prototypes; a small and large office, to evaluate multiple scenarios for compliance with demand response. We expected the economies of scale to allow a larger office building to prove more cost effective than a smaller one.

Small Office Prototype

The small office prototype is a building that was surveyed in 2005 by HMG, as part of a study on photocontrol systems conducted for the California investor-owned utilities, and the Northwest Energy Efficiency Alliance (Pacific Gas & Electric, et al 2006). This building was chosen because it is typical of the layout of many small California offices, which have a number of open office areas and single-person or multi-person offices around the perimeter, linked together by internal corridors. This specific building was also chosen because as part of the 2005 study we collected very comprehensive data on its lighting and control systems, and daylight distribution, and because we have both a reflected ceiling plan and a furniture layout for the entire building.

Large Office Prototype

This building was chosen because, unusually, it has a mix of both perimeter private offices and perimeter open office areas. This allowed us to accommodate both those common configurations within the same building model, rather than using two models. For structural reasons it is arranged around a central core, like the vast majority of larger office buildings. A reflected ceiling plan and a furniture layout were also available for this building.

Space Breakdowns for Each Prototype Building

The breakdown of rooms in the prototype small and large office buildings is shown in [Figure 3](#). This table allows for comparison of the space breakdowns, showing key differences between the two prototypes, such as the higher ratio of office space to total floor area for the larger office (81% vs. 68%) and the higher percentage of spaces devoted to corridors and ancillary functions in the small office. As will be shown in the analysis below, these features contribute to the comparatively higher costs in the small office prototype. The space types in the table are used to develop LPDs and therefore estimates of the total lighting energy use of the prototype buildings. The percentage of total installed lighting power by space type, assuming area category LPD allowances, is also displayed in the table below. This information is helpful in prioritizing which spaces within the office have the greatest demand response savings potential.

Type of room	Small Office Prototype				Large Office Prototype			
	Number of Rooms	Net Area [sf]	% of Floor	% of Total Wattage	Number of Rooms	Net Area [sf]	% of Floor	% of Total Wattage
Open Offices	5	4,358	53.0%	47%	6	21,675	63.6%	58%
Private Offices	5	1,260	15.3%	19%	36	5,934	17.4%	20%
Conference Rooms	2	402	4.9%	8%	3	1,810	5.3%	8%
Break Room					1	845	2.5%	3.5%
Restrooms	1	384	4.7%	4%	4	685	2.0%	1%
Mechanical/ Electrical					4	645	1.9%	1%
Corridor	5	981	11.9%	8%	5	600	1.8%	1%
(Elevator) Lobby	2	342	4.2%	7%	1	333	1.0%	2%
Kitchen	1	241	2.9%	5%	1	845	2.5%	3.5%
Stairs					2	306	0.9%	1%
Printer/copier	1	87	1.1%	1%	1	214	0.6%	<1%
Server room	1	75	0.9%	1%				
Storage	2	93	1.1%	1%	6	118	0.3%	<1%
Janitor					1	77	0.2%	<1%
TOTAL:		8,223	100%	100%		34,087	100%	100%

Figure 3 Breakdown of Spaces in Prototype Buildings

2.3 Compliance Scenarios

There are several available methods of enabling demand response in a lighting system using currently available technology. As the market for demand response grows and the variety of enabling products increases; so too will available methods of complying with this requirement for demand responsive lighting controls.

To address the various compliance methods, we first categorized the approaches for the application of demand responsive lighting controls into two distinct scenarios. The first scenario assumes the 2008 Title 24 requirements serve as the baseline lighting design, which includes multi-level lighting controls and shut-off controls as specified in sections 131(b) and (d), respectively. The subsequent scenarios assume dimmable lighting is the baseline in most nonresidential spaces, as proposed by the Controllable Lighting CASE team. These requirements include more levels of control, which we have assumed will be met by the use of a dimmable lighting system. If a switching system is installed, the scenario addressing the 2008 Title 24 base case would apply.

2.4 Savings Analysis Methodology

To estimate savings from the proposed changes, we need to estimate the typical lighting power density (LPD) for the prototype buildings. [Figure 4](#) below shows the 2008 and Proposed 2013 Area Category LPD space types typically found in offices. The typical relative square footage for an office is also presented as "% Area", sourced from Table 6.2 of the Database of Energy Efficient Resources final report (DEER 2005). These area breakdowns are relatively similar to those of the prototypes presented in [Figure 3](#).

The savings estimates assume the prototype buildings are in compliance with the proposed 2013 Title 24 area category LPD allowances. The area category LPDs are shown in [Figure 4](#).

Area Type	% Area	2008 Area Category LPD (W/sf)	Proposed 2013 Area Category LPD (W/ft ²)
Conference Room	4%	1.2	1.2
Copy Room	2%	0.6	0.6
Corridor	10%	0.6	0.6
Lobby	5%	1.1	1.1
Mechanical/Electrical	4%	0.7	0.7
Private Office	25%	1.1	1.1
Open Office	45%	0.9	0.8
Restrooms	5%	0.6	0.6
Weighted Average		0.91	0.86

Figure 4 Area Category LPD allowance for Office Spaces

The savings estimate is based on the hourly value of energy using Time Dependent Valuation (TDV) for the full load equivalent hours that lights are shut off due to demand response. Using 15-year nonresidential TDV values as a proxy for the peaks of dynamic pricing rates, the top 1% of TDV hourly values were identified (approximately 88 hours). The values were then filtered to only include those that fell on weekdays between 9am and 7pm. Assumptions used in the savings calculation are discussed in detail in Section 3.3. Key assumptions are summarized as follows:

- ◆ Customers are enrolled in a time-of-use utility pricing structure by their electricity provider (These rate structures are the default for commercial customers in California IOU territory)
- ◆ 70% of customers would participate in this rate and respond to high prices (30% opt out)
- ◆ Customers respond to the top 1% of hourly prices (approximately 88 hours each year)
- ◆ Customer respond by shedding 20% of their lighting load that is controlled for purposes of DR
- ◆ 10% of customers override the automated demand response for each peak hour
- ◆ Only high TDV hours that occur during normal business hours are included in the analysis (Monday - Friday, 9am to 7pm)

The PG&E Peak Day Pricing program for small/medium commercial customers serves as an example⁴, being the most recently implemented of the IOU rate based Demand Response programs. Key points are summarized below:

- ◆ 9-15 event days each year
- ◆ Each event day lasts 4 or 6 hours

Assuming 6 hours of participation on 15 days each year provides for 90 hours of demand response annually. This an almost identical number of hours as identified by selecting the top one percent of TDV values (88). Dynamic price rates such as Peak Day Pricing enhance the ability of utility rates to reflect the true cost of providing energy at different times of the day and year, representing the peaks in TDV values more closely than before.

2.5 Cost Analysis Methodology

Cost estimates were developed for the compliance scenarios identified in Section 3.2. There were various assumptions made about the granularity of control of the base case lighting system, as required by Title 24 Section 131(b). The scenario considered without Controllable Lighting utilizes the existing requirement for multi-level controls in 2008 Title 24 Section 131(b). Scenarios for the Controllable Lighting case are based on system types consistent with the requirements of the Controllable Lighting CASE proposal. These include a digitally addressable lighting system, a centralized powerline carrier dimming control system, and a zone based digital lighting system. Each of these systems is assumed to have dimmable ballasts.

The office prototypes were chosen for analysis because they will be the most difficult to implement in a manner that is cost effective. The combination of complex wiring for many small rooms and relatively low LPDs compared to other building types, lead to our conclusion that these compliance strategies can be scaled up to larger spaces, or space types with higher LPDs, and be shown to be cost effective. The complete building LPD allowances for nonresidential buildings are shown in [Figure 5](#). The building types with complete building LPDs lower than that of offices are: commercial & industrial storage buildings (warehouses), parking garages and “other”. Parking garages are not part of the scope of demand responsive lighting, and warehouses benefit from economies of scale and simplicity of design. Additionally, if warehouses reduce their LPD to below 0.5 W/sf, they can avoid triggering the requirement for enabling demand response. By showing that the proposed change is cost-effective in office buildings we will show that the proposed change is cost-effective for all nonresidential building types.

⁴ <http://www.pge.com/mybusiness/energysavingsrebates/demandresponse/peakdaypricing/facts/charges/>

TYPE OF USE	ALLOWED LIGHTING POWER (W/sf)
Auditoriums	1.5
Classroom Building	1.1
Commercial and industrial storage buildings	0.6
Convention centers	1.2
Financial institutions	1.1
General commercial and industrial work buildings	
High bay	1.0
Low bay	1.0
Grocery stores	1.5
Library	1.3
Medical buildings and clinics	1.1
Office buildings	0.85
Parking Garages	0.3
Religious facilities	1.6
Restaurants	1.2
Schools	1.0
Theaters	1.3
All others	0.6

Figure 5 Title 24 Table 146-E Complete Building Method LPD Values (Watts/sf)

Data regarding the costs of the various demand responsive lighting compliance scenarios were collected from a combination of interviews with lighting controls manufacturers, lighting designers, and utilizing Means Costworks equipment and labor cost estimates (RS Means 2010). This included interviews with representatives at:

- ◆ Douglas Lighting Controls
- ◆ Leviton
- ◆ Lutron
- ◆ Schneider Electric / Square D
- ◆ Watt Stopper

In these interviews, we established the following:

- ◆ Which of their systems were compatible for demand response purposes
- ◆ Which systems provided the least expensive or most risk-free approach to demand response
- ◆ The typical contractor price for the equipment
- ◆ How much labor is typically associated with installing each piece of equipment

Estimates of contractor costs and labor times provided by the manufacturers were used in conjunction with the labor rate for an electrician from RS Means CostWorks Online Construction Cost Data (RS Means 2010) to develop tailored cost estimates for each control system scenario in each of the two prototype buildings.

2.6 Lifecycle Cost (LCC) Analysis

HMG calculated lifecycle cost analysis using methodology explained in the California Energy Commission report *Life Cycle Cost Methodology 2013 California Building Energy Efficiency Standards*, written by Architectural Energy Corporation, using the following equation:

$$\Delta LCC = \text{Cost Premium} - \text{Present Value of Energy Savings}^{[1]}$$

$$\Delta LCC = \Delta C - (PV_{TDV-E} * \Delta TDV_E + PV_{TDV-G} * \Delta TDV_G)$$

Where:

ΔLCC	change in life-cycle cost
ΔC	cost premium associated with the measure, relative to the base case
PV_{TDV-E}	present value of a TDV unit of electricity
PV_{TDV-G}	present value of a TDV unit of gas
ΔTDV_E	TDV of electricity
ΔTDV_G	TDV of gas

We used a 15-year lifecycle as per the LCC methodology for nonresidential lighting control measures. LCC calculations were completed for two building prototypes, in all sixteen (16) climate zones analyzed, for high, low, and average load shed rates. This provided a range of cost effectiveness to accommodate for varying scenarios.

2.7 Cost Effectiveness Analysis

This proposal expands the requirement for DR lighting controls applied to controllable lighting in commercial buildings larger than 10,000 sf. Retail spaces with sales floors of 50,000 square feet and larger were required to have demand responsive lighting controls per the 2008 Title 24 code cycle. The analysis performed for the 2008 Title 24 updates showed that DR could be cost effective in retail stores as small as 25,000 square feet, even those permitting under the "Area" or "Whole Building" method of Title 24 compliance (PG&E 2008 – Demand Responsive Controls for Indoor Lighting). Retail stores are commonly equipped with lighting controls that support the ability for scene lighting

^[1] The Commission uses a 3% discount rate for determining present values for Standards purposes.

control. This ability is in line with the ability to participate in DR events, as the setting for a demand response scenario can be set up as one of the scenes. Additionally, the LPD in retail spaces is commonly much higher than those found in other space types, such as offices. For these reasons, it is assumed that for any size office space that is proven cost effective, retail space with equivalent size will also be found cost effective.

As shown in section 3 – Analysis and Results, there are several strategies identified that meet the proposed requirements for demand response. Analysis was done for the two office building prototypes previously described, because implementation of DR controls will be most expensive relative to other nonresidential building types. By showing that the proposed change is cost-effective in office buildings, we show that the proposed change is cost-effective in all types of nonresidential buildings.

2.8 Statewide Savings Estimates

The statewide energy savings associated with the proposed measures will be calculated by multiplying the energy savings per square foot with the statewide estimate of new construction in 2014. Details on the method and data source of the nonresidential construction forecast are in [Appendix C -- Non-Residential Construction Forecast details](#).

2.9 Stakeholder Meeting Process

All of the main approaches, assumptions and methods of analysis used in this proposal have been presented for review at one of three public Lighting Stakeholder Meetings funded by the California investor-owned utilities (Pacific Gas and Electric, Southern California Edison, and Southern California Gas Company).

At each meeting, the utilities' CASE team asked for feedback on the proposed language and analysis thus far, and sent out a summary of what was discussed at the meeting, along with a summary of outstanding questions and issues.

A record of the Stakeholder Meeting presentations, summaries and other supporting documents can be found at www.calcodesgroup.com. Stakeholder meetings were held on the following dates and locations:

- ◆ First Lighting Stakeholder Meeting: March 18th, 2010, Pacific Energy Center, San Francisco, CA
- ◆ Controls and DR topics Stakeholder Meeting: July 7th, 2010, San Ramon Conference Center, San Ramon, CA
- ◆ Second Lighting Stakeholder Meeting: September 21st, 2010, California Lighting Technology Center, Davis, CA
- ◆ Third Lighting Stakeholder Meeting: February 24th, 2011, UC Davis Alumni Center, Davis, CA

In addition to the Stakeholder Meetings, a Stakeholder Work Sessions covering specific technical issues on demand responsive lighting was held on October 26th, 2010.

3. Analysis and Results

This section describes our analysis and assumptions in detail.

3.1 Review of Market Assessment and Program Evaluation Literature

A comprehensive review of literature related to applying demand response requirements to nonresidential lighting systems provided the following highlights:

Commercial building lighting demand is largely coincident with total statewide peak demand and on peak days is responsible for 30% of the total demand during the 2:00 PM- 5:00 PM summer peak compared to 32% for A/C (Rubinstein et al 2007).

Types of controllers that can operate dimming ballasts and multi-level lighting include:

- ◆ Low-voltage digital
- ◆ Powerline-carrier
- ◆ Pure wireless communication protocols

In any dimming system, the ballasts and controllers must be able to speak and hear the same language. In the case of digital dimming systems, this language is either proprietary or an open standard. The Digital Addressable Lighting Interface (DALI) protocol has been a NEMA Standard (243-2004) in the United States since 2004 and seems to have been adopted by the lighting industry as the principal wired digital control protocol for dimming ballasts (Rubinstein et al 2007)

Studies conducted by National Research Council Canada found that occupants mostly did not notice dimming of 20% in areas with no or low levels of daylight. In areas with high daylight levels, occupants did not notice dimming up to 60% (Newsham et al. 2008). They also found that occupants would notice, but still accept, dimming of 40% with no or low daylight or 80% with high daylight levels. The Lighting Research Center (LRC) conducted a lab study under non-daylit conditions and found that 50% of subjects noticed an illuminance reduction of 15% over a few seconds, and that 50% of subjects accepted an illuminance reduction of 40%. LRC also looked at the effect of “bias”, and found that subjects would accept an additional 20-30% illuminance reduction if they were informed of the economic, social and environmental reasons for demand response (LRC 2003, pp22-40).

HMG conducted a demand response acceptance test during a pilot study of low ambient / task lighting for PG&E in which overhead lights were switched (not dimmed) by 30%, to a level of 12fc (PG&E 2009). Most occupants did not notice the event, and all occupants found the event acceptable based on occupant surveys conducted shortly after the event.

The California Investor Owned Utilities (IOUs) have begun to offer Automated Demand Response (Auto-DR) programs⁵. There are two types of Auto DR customers: hardware clients and software clients (Grover 2010). For hardware clients, a CLIR (Client & Logic with Integrated Relay) box is installed at the facility site that automatically triggers a load curtailment during a demand response event. Alternatively, for software clients, an XML signal is sent directly to the site's Energy Monitoring and Control System (EMCS).

The three electric IOUs; SDG&E, SCE, and PG&E, have made CPP the default rate for large commercial customers. The CPUC has approved plans to expand it to the default rate for all commercial customers, starting with PG&E⁶. CPP is a time-of-use rate with a multiplier that increases the price to the customer at times of peak demand, as determined by the utility provider or ISO.

- ◆ SDG&E increased focus on their Auto-DR program in 2009 with an incentive of \$300 per kW⁷
- ◆ The SCE Auto-DR program option was officially initiated at the end of 2007, with the first full program year completed in 2008⁸.
 - The Auto-DR program became a new element of the SCE Technical Assistance & Technology Incentive⁹ program in 2008, with incentives up to \$300 per KW of verified load reduction¹⁰
- ◆ PG&E plan for the 2009-2011 program cycle¹¹:
 - Lower customer incentives for the Auto-DR program from \$300 to \$250 per kW

3.2 Compliance scenarios

These scenarios utilize existing technology to prepare the lighting system in an office building to shed load for purposes of demand response. As long as the system is capable of shedding load in a way that maintains functionality of the spaces affected, it is considered demand response enabled.

Existing requirements in Title 24, including Section 131(d) automatic shutoff control, are assumed to require a centralized network connection to a timeclock or a control panel with built in timeclock functionality. Discussions with lighting and electrical designers and lighting control panel manufacturers reveal that dry contact inputs are a standard feature of lighting control panels on the market today; even base models. There are some exceptions to this assumption, for example a

⁵ <http://www.auto-dr.com/>

⁶ http://docs.cpuc.ca.gov/PUBLISHED/NEWS_RELEASE/114096.htm

⁷ SDG&E: http://www.sdge.com/business/esc/documents/PPP_workshop.pdf

⁸ SCE: http://www.sce.com/NR/rdonlyres/E779A538-F1FD-43CC-B256-D0863F07C7E2/0/080602_PBCCommercial.pdf

⁹ <http://www.sce.com/b-rs/demand-response-programs/demand-response-programs.htm>

¹⁰ <http://www.sce.com/b-rs/large-business/auto-demand-response.htm>

¹¹ PG&E: http://www.pge.com/tariffs/tm2/pdf/ELEC_PRELIM_EX.pdf

scenario where each space is connected to occupancy sensors, which meets the requirements for automatic shutoff control without the need for a timeclock. In this scenario, the assumptions for the zone based lighting system will apply, utilizing network adapters to enable each room to be monitored and controlled for demand response.

The addition of a device that brings Demand Response signals into the building is not included as part of the compliance scenarios. The requirements for this device could change depending upon the specific demand response program in which the participant is enrolled. The compliance scenarios here meet the requirement for demand responsive capabilities, meaning the lighting fixtures are connected appropriately to take advantage of the existing requirement for multilevel lighting control.

Specific compliance strategies are identified below; Strategy A begins with the assumption of the 2008 Title 24 Code as the baseline. The subsequent strategies consider the requirements of the controllable lighting CASE proposal as the baseline. The controllable lighting CASE proposes updates to Section 131(b) and associated table 131(a), requiring a higher granularity of control for lighting in nonresidential spaces larger than 100 square feet with an LPD greater than 0.5 W/sf. This higher granularity of control is assumed to generally require the lighting system to have dimming functionality. In these scenarios we assume that the addition of specific components and control wiring will be required to enable demand responsive capabilities that can take advantage of the increased granularity of the lighting controls.

We assume that the Controllable Lighting will be connected to a junction box within a zone; the size and scope of each zone can vary and does not affect our underlying assumptions. The code language leaves open the possibility of installing individual ballasts that are Internet Protocol (IP)-configured and can receive the demand response signal directly, if the occupant so desires. However, the means of enabling demand responsive lighting will most likely entail a single entry point for the demand response signal that is then connected to all of the controllable lighting in the floor/building. A reasonable location to receive the DR signal is at the existing lighting control panel, likely located in the electrical room. Alternatively, a zone based digital lighting system could require adapters installed in each room and networked together to enable demand responsive capabilities.

3.2.1 Strategy A: Bi-Level Wiring

This scenario utilizes the existing requirements in the 2008 Title 24 Section 131(b) for multi-level control. Multi-level controls are required to have at least one control step that is between 30% and 70% of design lighting power. To maintain a conservative estimate, it is assumed that the minimum step (30%) is used for demand responsive load shed.

Additional line voltage wiring from the control panel to each of the bi-level lighting zones would ensure that each branch of lighting in the bi-level switching zones can be controlled directly at the control panel. A separate relay would be designated to control the demand response circuit. The assumption includes the ability of the lighting control panel to receive and respond to an input. Dry contact inputs are the minimum input required to enable communication for purposes of demand response. This would enable the reception of demand response signals via a device similar to the one depicted in [Figure 17](#).

One compliance option resides at the circuit level. Switching off 15% of the lights in an eligible space or building is a simple and effective means of enabling demand response. Designing the circuits so

that all of the “demand response lighting” is on the same circuit allows for the use of relays to shut off the DR circuit upon reception of a demand response signal. Depending on the layout, enabling demand responsive lighting could require some additional wiring; it is also possible that some additional time would be required for an engineer to design a functional layout using the existing materials.

Interviews with stakeholders have indicated that under certain circumstances, installing dimmable lights could be a cost effective method of enabling demand response. The additional costs for dimmable ballasts and controllers could be offset by the savings of time that a lighting designer would have to spend to lay out a lighting system that effectively enables DR. Additionally, less wiring is needed for a dimmable scenario, and it becomes easier for future changes to take place, for purposes of demand response or otherwise. The added energy saving benefit of dimmable lighting shortens the time required for a return on investment. This could be a particularly attractive option if frequent tenant turnover is expected, and the lighting layout is expected to change repeatedly.

3.2.2 Strategy B: Addressable lighting system

The addressable lighting system is similar in design to that of a centralized control panel, but with additional granularity of control. With the addressable system each fixture can be addressed individually, whereas a centralized control panel is limited to an entire channel, or circuit, being controlled in unison. The cost of enabling demand response on a system with a centralized control panel is more independent of building size or number of rooms than the zone based system.

Enabling demand response for the addressable lighting system entails making a dry contact input available to receive an electronic signal. This is a feature that is included in the base model of most lighting control panels. Some smaller scale addressable lighting systems may have a limited number of inputs dedicated for alternative uses, such as a timeclock. If this is the case, an I/O input device can be added to the network to provide an additional closed contact input. This device can then transmit that signal to as many as five (5) local node controllers. Each local node controller can serve up to 100 ballasts (approximately 5,000 sf).

3.2.3 Strategy C: Centralized Powerline Dimming Control

This scenario uses a system that has centralized control of dimmable ballasts using a type of powerline carrier signal. There is no additional wiring required as the control signal travels over the existing power line. This can be a very effective means of enabling demand response in small scenarios, such as our small office prototype. This requires the use of a lighting control panel downstream of the breaker panel. The lighting circuit relays are replaced by circuit controllers, which can send the dimming signal via line voltage wires. The panel has seven (7) dry contact inputs that are dedicated levels of demand response. Different channels can be assigned to have different levels of dimming as part of the demand response. Local controls can be provided by either line voltage or low voltage controls.

If there are two different signals being sent to a particular group of ballasts, the system uses the lowest setpoint by default. This means that upon reception of a DR signal, if the default response is to set the ballasts to 70%, and a room is already set to 50%, it will stay at 50%. Any ballasts set higher than the demand response level will be trimmed to the programmed level. The level of response can be chosen

when the system is programmed, or reprogrammed if the building occupant wants to change the setting.

3.2.4 Strategy D: Digital Zone Based System

Enabling demand response for the zoned system entailed adding a network adapter to each room to be controlled for purposes of demand response. The network adapter allows for each room to be monitored and controlled by an energy management control system (EMCS). These types of systems are commonly used for HVAC systems, and to respond to demand response signals. The assumption is that if the building is installing an EMCS, the preference would be to add the lighting network to that existing demand response system. There is additional functionality that results from adding the lighting system to an EMCS. In addition to being able to control the lighting for demand response, the status of the lighting system can then be monitored by the EMCS. For example, occupancy sensors would be able to be used as triggers for the HVAC system, turning A/C on and off when people entered and left the room. Therefore the potential for savings from this type of system is higher than the value of the lighting load shed for demand response.

3.3 Savings Analysis

This section describes the analysis that was performed to determine the savings that will result from this measure.

As part of the literature review, information was collected about the current IOU DR program rates, specifically those related to dynamic pricing. The assumption underlying this CASE is that customers are enrolled in a time-of-use utility pricing structure. The criteria of the PG&E Peak Day Pricing program described in the methodology section 2.4 are similar to the method we chose to identify peak TDV hours. The analysis undertaken to identify these peak hours is described in detail here.

Figure 6 contains the top 1% of hourly TDV values, broken down by climate zone and hour of the day. The row labeled “99% TDV” is the 99th percentile of TDV values for that climate zone. This value was used as the cutoff value for identifying peak TDV values; the row below titled “avg TDV value >99% (M-F)” is the average value of all weekday TDV values identified in that climate zone that are higher than the 99th percentile. The data in the rows titled “Hour ending...” contain a count of how many peak TDV values occur during each labeled weekday hour. Hour ending 9 includes hourly values between 8:01 AM and 9:00 AM. The bottom row contains the total count of peak TDV hourly values that occur on weekdays between the hours of 8am and 7pm. For all but three climate zones (5, 7, and 8) each of the highest 88 hourly TDV values occurred between 8am and 7pm, Monday through Friday.

The weighted average of the TDV values identified by this exercise is \$16.13/kWh. This value is used in the cost effectiveness analysis in Section 3.5.

Climate Zone	CZ1	CZ2	CZ3	CZ4	CZ5	CZ6	CZ7	CZ8	CZ9	CZ10	CZ11	CZ12	CZ13	CZ14	CZ15	CZ16
Minimum TDV	0.92	0.91	0.91	0.91	0.92	0.90	0.94	0.91	0.90	0.90	0.91	0.91	0.91	0.89	0.90	0.89
Maximum TDV	16.75	24.16	28.26	25.90	20.61	35.34	31.61	24.55	32.67	24.68	25.06	21.08	17.60	15.38	15.74	22.94
Average TDV	2.00	1.99	1.99	1.99	2.00	1.99	2.02	1.99	1.98	1.98	1.99	1.99	1.99	1.98	1.98	1.97
99 th percentile TDV	9.41	10.65	10.01	10.20	9.62	9.27	10.00	10.16	10.09	10.76	10.87	12.05	11.05	10.60	9.87	10.90
avg TDV value >99% (M-F)	12.93	17.57	17.79	16.67	13.25	18.75	17.62	14.58	20.24	17.70	18.96	16.79	13.82	13.16	12.21	17.26
Hour ending 9	0	0	2	0	4	2	5	2	2	1	0	0	0	0	0	0
Hour ending 10	3	2	4	3	7	9	5	8	5	4	1	1	1	1	0	2
Hour ending 11	5	8	8	5	9	11	6	9	8	10	5	1	2	5	3	5
Hour ending 12	8	12	14	11	12	11	11	12	13	18	9	9	8	10	12	10
Hour ending 13	16	16	15	15	13	13	12	14	17	19	13	14	15	17	16	18
Hour ending 14	19	17	16	16	14	13	13	15	15	16	13	14	17	18	17	24
Hour ending 15	18	16	14	16	15	13	14	14	13	12	15	17	18	16	19	18
Hour ending 16	13	10	10	14	9	12	12	8	10	6	15	14	17	13	14	8
Hour ending 17	6	4	4	6	4	3	3	3	3	1	10	12	8	6	6	3
Hour ending 18	0	3	1	2	0	1	2	2	1	1	6	5	1	2	1	0
Hour ending 19	0	0	0	0	0	0	1	0	1	0	1	1	1	0	0	0
# of hours (8am-7pm):	88	88	88	88	87	88	84	87	88	88	88	88	88	88	88	88

Figure 6 Hourly TDV Values Triggering Demand Response

The savings estimate is based on the value of TDV for the full load equivalent hours that lights are shut off due to price based demand response events.

Figure 7 summarizes the assumptions about rates of participation and load shed from commercial customers. Under the controllable lighting proposal, which is assumed to be the baseline for this measure, the lights will be tuned down by a factor of 15% at time of inspection. The assumptions about enrollment rate, participation rate, and signal reception are consistent with the assumptions used in the 2008 Title 24 DR code change proposal (Pacific Gas & Electric 2007). We assume that 70% of customers remain enrolled in their default utility time-of-use pricing structure, and therefore would utilize their demand response capabilities in response to the top 1% of prices. This is based on time-of-use or real-time pricing being the default rate, and 30% of customers choosing to opt-out (Pacific Gas & Electric 2007). Additionally we assume that the demand response price signal is received 97% of the time, allowing for any technical difficulties or disruption in service to be accounted for in our estimate of savings. We also assumed that 10% of the time, a building owner or occupant would override the automated load shed during a DR event; depicted as the “Participation Rate”. The estimated load shed is 20% of the installed lighting load. This is based on the premise that occupants will accept a 40% reduction of dimmable lighting with no or low daylight levels (Newsham 2008), and at least 50% of the installed lighting load would be designated as available for demand response. These assumptions add a level of conservatism to the estimates of savings; a building owner could theoretically achieve greater energy savings with a more aggressive approach, utilizing the same equipment installed to meet this proposed requirement.

Tuning	15%
Enrollment Rate	70%
Signal Reception	97%
Participation Rate	90%
% Load Shed	20%

Figure 7 Assumptions for demand responsive lighting load shed

The total adjustment to the 20% load shed from the other factors presented in **Figure 7** is 52%. This results in an adjusted load shed of 10.4% for use in statewide estimation of savings.

Figure 8 shows the lighting power density (LPD) assumed for commercial building types affected by the proposed demand responsive lighting controls requirement. For all building types we compared the proposed 2013 Title 24 LPD values to the CEUS LPD values and chose the lower LPD value of these two sources in order to generate a conservative estimate for calculating energy savings. Offices and schools use the Title 24 LPD allowance from Table 146-E (complete building method). Hotels use the area category method for Corridors because that is the majority of the floorspace that will be required to be capable of being controlled for demand response, unless it is designed below the 0.5 W/sf threshold. The other building types use CEUS estimated interior lighting power density values.

Building type	Building LPD (W/sf)	Building LPD Source	Adjusted Load Shed (W/sf)
Office	0.80	Proposed 2013 Title 24	0.08
Retail	1.34	CEUS	0.14
Warehouse	0.65	CEUS	0.07
Refrigerated Warehouse	0.68	CEUS	0.07
Grocery Store	1.34	CEUS	0.14
Hotel	0.6	Title 24 Area Category Method for Corridors	0.06
Restaurant	1.17	CEUS	0.12
Schools	1.00	Proposed 2013 Title 24	0.10

Figure 8 Lighting Power Density and Adjusted Load Shed by Building Type

The Adjusted Load Shed in last column of [Figure 8](#) is the product of the building LPD and the assumptions identified in [Figure 7](#). The adjusted load shed is multiplied by the number of hourly TDV values in each climate zone and the average TDV value of those hours of energy as identified in [Figure 6](#). Each building type in each climate zone then has a sum product of the value of energy saved over the course of 15 years. These TDV savings values by building type and by climate zone are presented in [Figure 9](#). The bottom row contains the savings values in dollars per square foot, averaged across all climate zones, weighted by commercial building stock in each climate zone according to forecast data provided by the California Energy Commission (CEC 2010). The rightmost column contains the savings per square foot averaged across building types, weighted by relative floor space.

	Office	Retail	Warehouse	Refrigerated Warehouse	Grocery Store	Hotel	Restaurant	Schools	Average Savings Weighted by Building Types
CZ1 (\$/sf)	\$0.09	\$0.16	\$0.08	\$0.08	\$0.16	\$0.07	\$0.14	\$0.12	\$0.12
CZ2 (\$/sf)	\$0.13	\$0.22	\$0.10	\$0.11	\$0.22	\$0.10	\$0.19	\$0.16	\$0.16
CZ3 (\$/sf)	\$0.13	\$0.22	\$0.11	\$0.11	\$0.22	\$0.10	\$0.19	\$0.16	\$0.17
CZ4 (\$/sf)	\$0.12	\$0.20	\$0.10	\$0.10	\$0.20	\$0.09	\$0.18	\$0.15	\$0.16
CZ5 (\$/sf)	\$0.10	\$0.16	\$0.08	\$0.08	\$0.16	\$0.07	\$0.14	\$0.12	\$0.12
CZ6 (\$/sf)	\$0.14	\$0.23	\$0.11	\$0.12	\$0.23	\$0.10	\$0.20	\$0.17	\$0.17
CZ7 (\$/sf)	\$0.12	\$0.21	\$0.10	\$0.10	\$0.21	\$0.09	\$0.18	\$0.15	\$0.16
CZ8 (\$/sf)	\$0.11	\$0.18	\$0.09	\$0.09	\$0.18	\$0.08	\$0.15	\$0.13	\$0.13
CZ9 (\$/sf)	\$0.15	\$0.25	\$0.12	\$0.13	\$0.25	\$0.11	\$0.22	\$0.19	\$0.19
CZ10 (\$/sf)	\$0.13	\$0.22	\$0.11	\$0.11	\$0.22	\$0.10	\$0.19	\$0.16	\$0.16
CZ11 (\$/sf)	\$0.14	\$0.23	\$0.11	\$0.12	\$0.23	\$0.10	\$0.20	\$0.17	\$0.18
CZ12 (\$/sf)	\$0.12	\$0.21	\$0.10	\$0.10	\$0.21	\$0.09	\$0.18	\$0.15	\$0.16
CZ13 (\$/sf)	\$0.10	\$0.17	\$0.08	\$0.09	\$0.17	\$0.08	\$0.15	\$0.13	\$0.13
CZ14 (\$/sf)	\$0.10	\$0.16	\$0.08	\$0.08	\$0.16	\$0.07	\$0.14	\$0.12	\$0.12
CZ15 (\$/sf)	\$0.09	\$0.15	\$0.07	\$0.08	\$0.15	\$0.07	\$0.13	\$0.11	\$0.11
CZ16 (\$/sf)	\$0.13	\$0.21	\$0.10	\$0.11	\$0.21	\$0.09	\$0.18	\$0.16	\$0.16
Average Savings Weighted by Climate Zones (\$/sf)	\$0.12	\$0.20	\$0.10	\$0.10	\$0.20	\$0.09	\$0.17	\$0.15	\$0.14

Figure 9 Statewide Savings (\$/sf) from DR Lighting by Climate Zone and Building Type

It is important to note that some current demand response programs provide an additional economic incentive for verified load shed of up to \$300 per kW¹². We have chosen to ignore those additional payments, which simplifies the calculation of savings and under-estimates the potential cost savings that would be realized by participants in actual DR programs.

3.4 Cost Analysis

Data regarding the costs of the various demand responsive lighting compliance scenarios was collected from a combination of interviews with lighting controls manufacturers, lighting designers, and Means Costworks (RS Means 2010) equipment and labor cost estimates.

In developing this proposal, we want to make sure that the lighting system is capable of being used for demand response. There are products currently available on the market that brings an Automated Demand Response signal into the building. The requirements for this device could change depending upon the specific demand response program in which the participant is enrolled. The assumption is that this component is added by the building owner/operator at the time of enrollment in a demand response program. The compliance scenarios here meet the requirement for demand responsive capabilities, meaning the lighting fixtures are connected appropriately to take advantage of the existing requirement for multilevel lighting control. The cost of adding this component is not being included in this analysis. Similarly for an alternative compliance scenario, we are including the cost of preparing a lighting network to communicate with an energy management control system (EMCS), but not the cost of the EMCS itself.

There are several possible compliance methods for enabling demand responsive capabilities, as described in Section 3.2 above. The associated equipment and labor costs used in our scenario estimates are displayed in [Figure 10](#). The focus of our compliance estimates was for the prototype buildings presented in Section 2.2. The emphasis was on office buildings since we assumed that they would be harder to prove cost effectiveness, and represent a large percentage of commercial building stock (Rubinstein et al 2007). Retail is another large portion of commercial floor space; however the higher LPDs and more sophisticated lighting controls in the baseline scenarios allowed us to assume that proving cost effectiveness for offices would also demonstrate retail spaces being cost effectively able to include demand responsive capabilities in new construction.

¹² <http://www.auto-dr.com/>

ID	Description	Unit	Bare Material (equip cost to contractor)	Cost Source	Labor hours to install each unit	Labor cost	Total O&P (includes labor, overhead and profit)
1	Relays, 120 V or 277 V standard	Ea.	\$38	RS Means	0.667	\$57	\$90
2	line-voltage wires (600 volt, THW, copper, #12, solid)	100 linear feet	\$12	RS Means	0.727	\$63	\$78
3	Digital Lighting Network Adapter	Ea.	\$100	Manufacturer	1	\$86	\$214
4	#18-2conductor wire - thermostat, jacket non-plenum	100 linear feet	\$13	RS Means	(labor included in network adapter cost assumption per room)		\$17
5	Addressable network I/O device	Ea.	\$500	Manufacturer	0.5	\$43	\$683
6	Addressable Network Programming Interface	Ea.	\$150	Manufacturer	(labor included in programming DR response)		\$192
7	Programming DR response	Each building	Varies by scenario	Manufacturer	4	\$344	\$344
8	Control wire, 2 conductor	100 linear feet	\$18	RS Means	1.27	\$109	\$132
9	Power-line dimming head-end controller	Ea	\$500	Manufacturer	-	-	\$640
10	Power-line dimming circuit controller	Ea	\$100	Manufacturer	1	\$86	\$214

Figure 10 Costs associated with various demand response enabling strategies

Strategy A: Bi-level Wiring Costs

Enabling demand response using the bi-level lighting scenario requires additional wiring and relays to provide for the demand response circuit(s). Costs to install an additional relay and #14 line voltage wires were quoted from Means Costworks (RS Means 2010) in [Figure 10](#) on lines 1 and 2, respectively. We assumed that an additional run of line voltage was required from the control panel to the area being controlled for demand response. This additional run allows the multi-level switching capabilities to be controlled from the control panel by the relay that was added. Multi-level control capabilities are already required by Title 24 Section 131(b) and are sufficient to enable demand response. The number of additional relays required depends on the amount of wattage being

controlled for demand response. Assuming that one relay per 277V circuit is loaded with 10 amps on average; would require one relay for each 2,770 Watts of load being controlled for demand response.

$$277 \text{ Volts} * \frac{10 \text{ amps}}{\text{circuit}} = 2,770 \frac{\text{Watts}}{\text{circuit}}$$

The equation used to determine cost per square foot of building area controlled for demand response for Strategy A is as follows:

$$\frac{\left[\left(\frac{\text{Area}}{10} * \frac{\text{LVwire}}{100\text{ft}} \right) + \left(\text{Relay} * \frac{\text{LP}}{2,770\text{Watts}} \right) \right]}{\text{Area}}$$

Where:

Area = Total Area Controlled for Demand Response (in square feet)

LVwire = cost of line voltage wire in \$/100 linear feet, as depicted in Line 2 of [Figure 10](#)

Relay = cost of a relay, as depicted in Line 1 of [Figure 10](#)

LP = Sum of Lighting Power (in Watts) for total area controlled for DR

Strategy B: Addressable Lighting System Costs

Enabling demand response for the addressable lighting system entails making a dry contact input available to receive an electronic signal. This is a feature that is included in the base model of most lighting control panels, however in some smaller scale addressable lighting systems, there may be a limited number of inputs, and they can already be dedicated for alternative uses, such as a timeclock. If this is the case an I/O input device can be added to the network to provide an additional closed contact input. This device can then transmit that signal to as many as five (5) local node controllers.

The cost of the addressable network I/O device is \$683.05 including installation and contractor markup, as shown on line 5 of [Figure 10](#). This device can attach to up to four (4) nodes. Each node includes two lighting control loops, each with a maximum of 64 ballasts or ballast modules. This accounts for a maximum of 128 ballasts per node. Contractors commonly install to 80% of capacity, to leave room for future additions; so we assume there will be a maximum of 100 ballasts connected per node. For purposes of calculating how much floor space can be served by 100 ballasts, we assumed that each ballast accounts for approximately 40 Watts. This builds in some conservatism to our estimate since a commonly installed lighting fixture is 2-lamp or 3-lamp T8 (Heschong Mahone Group 2009). Therefore each node can carry approximately 4,000 Watts. With offices in the range of 0.8 – 1.0 Watts/sf, each node is serving 4,000-5,000 sf. Connecting each I/O device to 4 nodes would serve as much as 20,000 sf. Adding each node would entail some additional wiring.

The system response logic needs to be programmed into the node controller. This can be performed either by the contractor if he has an understanding of the programming language, or by the manufacturer representative when the entire system is commissioned. There is an additional programming interface required to program the desired load shed of the system during demand response events. The additional cost for this interface is \$192, depicted in line 6 of [Figure 10](#). Programming the system is necessary regardless of whether demand response is added to the system or not. Therefore the entire cost of this device should be shared among the various lighting controls

that require programming. We then add 4 hours of labor to program the demand response settings, which is a mostly fixed cost, regardless of size of the building. At an electrician's rate of \$86/hr, this programming adds an additional \$344 to the cost of the system.

The fixed cost components are the programming interface (\$192, line 6), time (\$344, line 7) and the I/O device (\$683, line 5), summing to \$1,219. The fixed cost per square foot ranges from \$0.24/sf for a 5,000sf space to \$0.06/sf for a 20,000 sf floor plan. The additional control wiring costs \$132 per 100 linear feet (line 8). Assuming a 20,000 sf rectangular office floor plan and a worst case scenario of each node located in a different corner of the building, we estimate requiring approximately 200 linear feet of wiring per node added to connect to the I/O device centrally located in the electrical room. This adds about \$0.05/sf to the total DR cost for each node added to the system (approximately every 5,000 sf).

The cost of enabling demand response for an addressable lighting system is comprised almost entirely of the initial fixed cost of adding an input to receive DR signals and the programming interface to setup the load shed settings. As mentioned previously, for some systems this capability is built in to the control panel, and therefore the added cost is solely based on the programming interface and labor time of programming the load shed settings.

The equation used to determine cost per square foot of building area controlled for demand response for Strategy B is as follows:

$$\frac{\left[\text{Interface} + \text{Program} + \left(\frac{\text{Area}}{4000\text{sf}} * 2 * C_{\text{wire}} \right) + \left(\text{IO} * \frac{\text{LP}}{(4 * \text{Node} * 4000\text{W} / \text{Node})} \right) \right]}{\text{Area}}$$

Where:

Interface = Cost of a programming interface as depicted in Line 6 of [Figure 10](#)

Program = Cost to program the demand response load shed settings, as depicted in Line 7 of [Figure 10](#)

Area = Total Area Controlled for Demand Response (in square feet)

C_{wire} = cost of control wire in \$/100 linear feet, as depicted in Line 8 of [Figure 10](#)

IO = cost of addressable input (I/O) device, as depicted in Line 5 of [Figure 10](#)

LP = Sum of Lighting Power (in Watts) for total area controlled for DR

Node = Controller for approximately 100 addressable ballasts (up to 4 can share a single I/O device)

Strategy C: Centralized Powerline Dimming Control Costs

This scenario uses a system that has centralized control of dimmable ballasts using a type of powerline carrier signal. There is no additional wiring required as the control signal travels over the existing power line. This can be a very effective means of enabling demand response in small scenarios, such as our small office prototype. This requires the use of a lighting control panel downstream of the breaker panel. The lighting circuit relays are replaced by circuit controllers, which can send the dimming signal via line voltage wires. The panel has seven (7) dry contact inputs that are dedicated levels of demand response. Different channels can be assigned to have different levels of

dimming as part of the demand response. Local controls can be provided by either line voltage or low voltage controls.

If there are two different signals being sent to a particular group of ballasts, the system uses the lowest setpoint by default. This means that upon reception of a DR signal, if the default response is to set the ballasts to 70%, and a room is already set to 50%, it will stay at 50%. Any ballasts set higher than the demand response level will be trimmed to the programmed level. The level of response can be chosen when the system is programmed, or reprogrammed if the building occupant wants to change the setting.

The cost of the circuit controller to replace the relays is \$100 more than the cost of a relay, as indicated on line 10 of [Figure 10](#). The circuit controller sends the dimming signal on the line voltage wire to the ballasts. The head-end controller is also required as the “brains”. The controller interprets the dry contact input and tells each assigned group of circuit controllers what light level to set; it costs \$500. The cost of this system is dependent upon the number of circuits that need to be controlled, but with a fixed cost of \$500 for the controller. Labor time for installation of a line-voltage relay from Means Costworks (RS Means 2010) was used to estimate the labor cost of setting up this system.

The equation used to determine cost per square foot of building area controlled for demand response for Strategy C is as follows:

$$\frac{\text{Brain} + \text{Program} + \left(\frac{LP}{2770W} * PLC \right)}{\text{Area}}$$

Where:

Brain = Powerline dimming head-end controller cost, as depicted in Line 9 of [Figure 10](#)

Program = Cost to program the demand response load shed settings, as depicted in Line 7 of [Figure 10](#)

LP = Sum of Lighting Power (in Watts) for total area controlled for DR

PLC = Cost of Powerline circuit controller as depicted in Line 10 of [Figure 10](#)

Area = Total Area Controlled for Demand Response (in square feet)

Strategy D: Digital Zone Based System Costs

Enabling demand response for the zoned system entailed adding a network adapter to each room to be controlled for purposes of demand response. The network adapter allows for each room to be monitored and controlled by an energy management control system (EMCS). These types of systems are commonly used for HVAC systems. The assumption is that if the building is installing an EMCS, which is defined by Title 24 as being equipped with demand response functionalities, the preference would be to add the lighting network to that existing demand response system. There is additional functionality that results from adding the lighting system to an EMCS. In addition to being able to control the lighting for demand response, the status of the lighting system is then available to the EMCS. For example, occupancy sensors could also be used as triggers for the HVAC system, turning A/C on and off when people entered and left the room. Therefore the potential for savings from this type of system is higher than the value of the lighting load shed for demand response.

Cost per network adapter was quoted by the manufacturer at \$100 wholesale, with one network adapter required per room added to the network. Installation is estimated by the manufacturer at 20 minutes per adapter by an electrician, with an additional 40 minutes to install the wiring to add each room to the network. The sum of lines 3 and 4 in [Figure 10](#) is the cost per adapter installed, assuming the labor rate of \$86.11 per hour for a union electrician in California in 2010 (RS Means 2010). Commissioning of the EMCS would be required to set up the HVAC system. We are assuming a flat rate of 4 hours of additional labor time would be required to add the network adapters for the lighting system to the EMCS.

The cost for this strategy depends entirely on the floor plan. There is a fixed cost component of setting up the network adapters with the EMCS (\$344). Then there is the cost of adding each room to that network (\$214 plus wiring cost – dependent on size of room). Starting with the largest rooms in the building such as the open office areas and conference rooms, the cost per sf rapidly decreases. This can be seen in [Figure 11](#) and [Figure 12](#) in Section 3.5 - Cost Effectiveness Analysis. As the size per room decreases, the marginal cost of controlling each additional room increases. In practice, the smallest rooms of the prototype would not be connected to this network. The proposed controllable lighting requirements exclude spaces less than 100 sf or with an LPD of less than 0.5 W/sf. The last several rooms of both prototypes identified in this report would be exempt from the controllable lighting requirement based on size.

The equation used to determine cost per square foot of building area controlled for demand response for Strategy D is as follows:

$$\frac{[Program + (Rooms * NA) + (\frac{Area}{10} * \frac{AWire}{100})]}{Area}$$

Where:

Program = Cost to program the demand response load shed settings, as depicted in Line 7 of [Figure 10](#)

Rooms = Number of individual rooms making up the Total Area Controlled for DR

NA = Cost of the network adapter required to add each room to the EMCS network

AWire = cost of #18 2-conductor wire in \$/100 linear feet, as depicted in Line 4 of [Figure 10](#)

Area = Total Area Controlled for Demand Response (in square feet)

3.5 Cost Effectiveness Analysis

Cost effectiveness of enabling demand response in the small and large office prototypes is depicted graphically in [Figure 11](#) and [Figure 12](#), respectively. These graphs show the savings from demand responsive lighting controls as dashed blue lines. The dashed blue lines show the savings per square foot of the area being controlled for DR. The lighter blue dashed line shows the dollar value of energy saving, assuming 20% of the watts for the area controlled are shed 87 hours each year over the 15 year life cycle. This dollar value is the weighted average of the average TDV value for the top 1% of hours (line 6 of [Figure 6](#)), ~\$16/kWh. The lower, darker blue line reflects the adjusted load shed potential based on the full set of assumptions in [Figure 7](#), reflecting enrollment rate, participation rate

etc. The x-axis for this graph is the area in square feet that is being made available for demand response. The y-axis is the cost in \$/sf (left axis) and savings in TDV \$/sf (right axis).

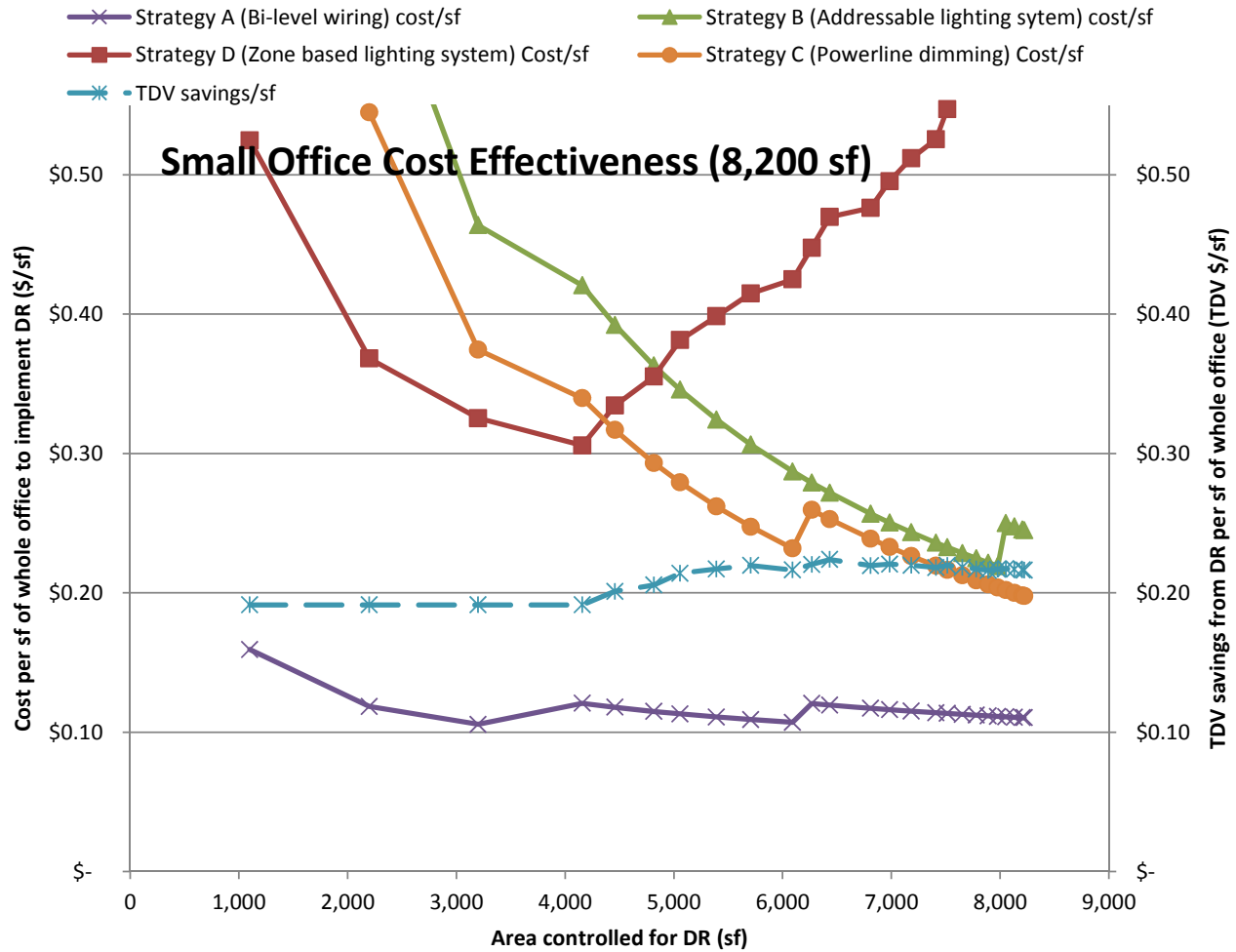

Figure 11 Cost Effectiveness of DR in Small Office Prototype

Each marker represents an additional room being controlled for DR. The largest rooms with the most available lighting load were controlled first, as this is the most cost effective approach. The breakdown of rooms is available in [Figure 3](#). The solid colored lines show the cost of each proposed compliance strategy, per square foot, at increasing amounts of area controlled. [Figure 11](#) depicts the cost effectiveness for the small office prototype building, beginning with the open office areas and progressively adding smaller rooms until the entire floor plan is DR enabled.

Strategy A: bi-level lighting (purple with “x” markers) represents a mostly variable cost of wiring, with additional relays required when load reaches more than 2700 Watts. This is reflected in the relatively constant cost per square foot. Strategies B and C reflect a high fixed cost with low marginal cost of adding subsequent areas of the building to be controlled for DR, resulting in a declining cost per square foot as the floor area being controlled for DR increases. Strategy D, the zone based system, (red with square markers) has a mix of fixed and variable costs, reflected in the U-shaped cost curve.

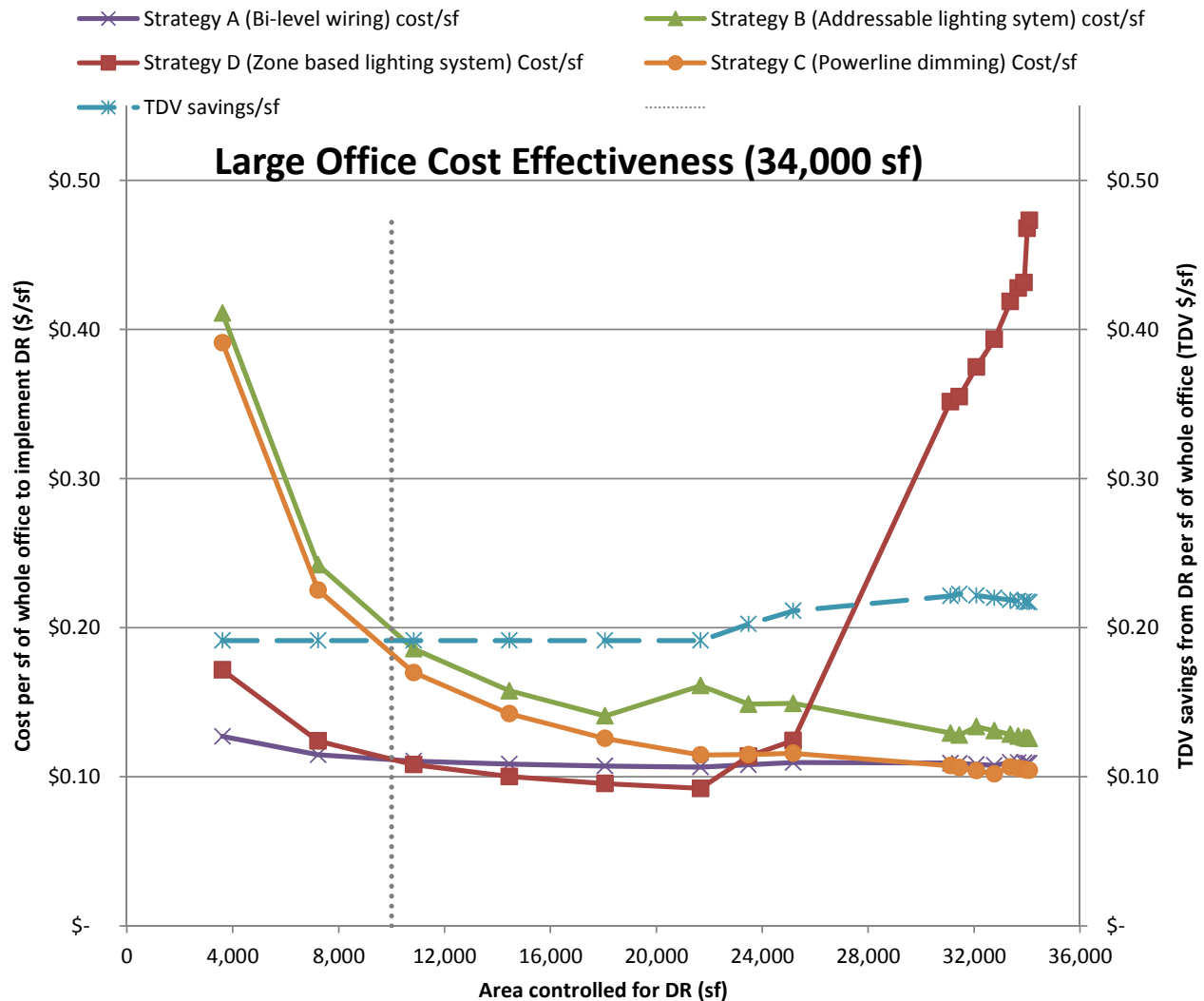

Figure 12 Cost Effectiveness of DR in Large Office Prototype

The graphs show that there are at least two compliance strategies that are cost effective for buildings with more than 10,000 sf of lighting controlled for demand response. The dashed gray line represents the proposed size threshold of 10,000 sf. As mentioned previously in the methodology, it is assumed that cost effectiveness demonstrated in offices translates to other nonresidential building types as well.

It is important to note that the last several data points on both [Figure 11](#) and [Figure 12](#) represent the smallest spaces in each prototype; storage closets, janitor’s closet, server room, etc. These spaces

generally will be too small to trigger the requirement for controllable lighting, which excludes spaces less than 100sf, less than 0.5 W/sf, or with only one lighting fixture.

3.6 Statewide Demand Response Savings

To assess the statewide savings potential presented in [Figure 13](#), we obtained data from the CEC¹³ regarding total construction and new construction by building type (column a). The approximate percentage of floorspace larger than 10,000 sf for each building type (column b) was calculated from data obtained from the Table A6 of the 2003 Commercial Building Energy Consumption Survey (CBECS 2006). These percentages were applied to the estimates of new construction to calculate the floorspace affected by the proposed code change. The annual savings in kWh/sf (column c) was calculated using the adjusted load shed values presented in [Figure 8](#) and multiplying by the number of peak hours identified in [Figure 6](#).

The estimate of statewide savings was calculated by multiplying the estimate of new construction, percent of floor space affected, and annual savings (columns a, b, and c in [Figure 13](#)). Total statewide savings were estimate for the building types shown in [Figure 13](#). There were an additional 32 million square feet of new construction estimate for the “miscellaneous” building type. Not enough information was available about type, size or lighting power density of building in the miscellaneous category to calculate a statewide savings estimate for that sector. The sum total of the annual statewide energy savings presented in [Figure 13](#) is 875 MWh.

The statewide demand savings is presented using two different calculations. The statewide demand savings using 250 peak hours uses the CEC approved demand allocation factors that allocate the demand savings on 250 specific hours that have been defined as peak by the CEC. The savings from those hours are weighted and summed, resulting in the 3.68MW of peak demand savings. The other method presented calculates the average demand savings over the peak period defined as 12pm to 6pm on weekdays between July and September. This method is how the CPUC defines peak demand for purposes of calculating IOU program savings. The statewide demand savings from demand responsive lighting controls over this peak period is 1.44 MW.

¹³ “NonRes Construction Forecast by BCZ v7”; Developed by Heschong Mahone Group with data sourced September, 2010 from Sheridan, Margaret at the California Energy Commission (CEC).

Building Type	Office	Retail	Warehouse	Refrigerated Warehouse	Grocery Store	Hotel	Restaurant	Schools	Total Statewide
2014 New Construction (millions sf)	36.78	32.44	32.07	1.75	8.51	9.10	5.08	9.98	103
Percent of Floorspace in Buildings >10,000sf	81%	83%	83%	83%	39%	41%	40%	91%	76%
Annual Energy Savings (Wh/sf)	7.28	12.20	5.92	6.19	12.20	5.46	10.65	9.10	71.37
Statewide Energy Savings (MWh)	216.98	326.85	156.56	8.95	40.48	20.37	21.65	82.63	883.3
Demand savings (250 Peak Hours) (MW)	0.90	1.36	0.65	0.04	0.17	0.12	0.09	0.34	3.68
Average Peak Demand Savings (Weekdays 12pm - 6pm, July - Sept) (W/sf)	0.01	0.02	0.01	0.01	0.02	0.01	0.02	0.02	1.44
Statewide Average Peak Demand Savings (Weekdays 12pm - 6pm, July - Sept) (MW)	0.36	0.54	0.26	0.01	0.07	0.03	0.04	0.14	12.31

Figure 13 Statewide Annual Energy and Demand Savings

4. Recommended Language for the Standards Document, ACM Manuals, and the Reference Appendices

An exception for non-addressable luminaires is proposed below, due to the technical limitation of a 0-10V dimming ballast being unable to receive two competing control voltage inputs. To our knowledge, this issue does not have any common solutions using existing equipment. It is reasonable that a product could be developed in the near future that would alleviate this issue, but to the best of our knowledge it does not exist currently, so we have included this exception in the language.

In the following proposed language additions are shown bold and underlined and deletions are shown in strikeout and italics.

4.1.1 Section 101(b) Definitions

ADDRESSABLE LUMINAIRE is a luminaire that receives networked control signals and determines whether to respond to those signals based on an address programmed into the luminaire.

DEMAND RESPONSE is ~~controlling electricity loads in buildings in response to an electronic signal sent by the local utility requesting their customers to reduce electricity consumption.~~ **short-term changes in electric usage by end-use customers from their normal consumption patterns in response to changes in the price of electricity over time, or to incentive payments designed to induce lower electricity use at times of high wholesale market prices or when system reliability is jeopardized.**

DEMAND RESPONSE PERIOD is a period of time during which ~~the local utility is curtailing~~ electricity loads **are curtailed in response to** ~~by sending out~~ a demand response signal.

DEMAND RESPONSE SIGNAL is ~~an electronic signal sent out by the local utility indicating a request to their customers to curtail electricity consumption.~~ **a signal sent by the local utility, Independent System Operator (ISO), or designated curtailment service provider or aggregator indicating a price or a request to their customers to curtail electricity consumption for a limited time period.**

DEMAND RESPONSIVE ~~LIGHTING~~-CONTROL is a control that ~~reduces lighting power consumption in response to a demand response signal.~~ **is capable of receiving and automatically responding to a demand response signal sent via a third-party network or device.**

4.1.2 Section ~~131(e)~~**130.1(e)**

~~(eg) Demand Responsive Lighting Controls. Demand responsive automatic lighting controls that uniformly reduce lighting power consumption by a minimum of 15 percent shall be installed in retail buildings with sales floor areas greater than 50,000 square feet.~~

1. In buildings larger than 10,000 square feet, lighting required to comply with Section 131(b) shall be capable of being automatically reduced by a demand responsive control as follows:

A. By a minimum of 15 percent for continuous dimming systems, or

B. By one level below full ON in accordance with Table 131-A for stepped dimming or stepped switching.

EXCEPTION 1 to Section 131 ~~(eg): Buildings where more than 50 percent of the lighting power is~~

~~controlled by daylighting controls.~~ **Luminaires that receive a dimming signal only from a Photo Control.**

Section 130.5(e)

(e) Demand Response Signals. Demand response signals shall conform to a nationally recognized open communication standard. Acceptable standards include those defined by groups such as the Organization for the Advancement of Structured Information Standards (OASIS), Energy Interoperation Technical Committee (also known as Energy InterOp and OpenADR) or the ZigBee Alliance (also known as Smart Energy profile).

[For the scenario where the controllable lighting proposal *is not* adopted]

Section 130.1(e) Demand Responsive Lighting System. Buildings larger than 10,000 square feet, excluding residential common areas, areas with automatic daylight controls, or any space with an LPD less than or equal to 0.5 W/s.f., shall have demand responsive controls capable of temporarily limiting lighting power to no more than 85% of the permanently installed lighting power in the enclosed space. If general lighting is reduced, it must be done in a uniform manner in accordance with Table 131(a).

4.1.3 TABLE 146-C LIGHTING POWER ADJUSTMENT FACTORS

TYPE OF CONTROL		TYPE OF SPACE				FACTOR
Multi-level occupant sensor (see Note 2) combined with multi-level circuitry and switching in accordance with Section 146(a)2D		Any space ≤ 250 square feet enclosed by floor-to-ceiling partitions; any size classroom, corridor, conference or waiting room.				0.20
Multi-level occupant sensor (see Note 2) that reduces lighting power at least 50% when no persons are present. May be a switching or dimming (see Note 3) system.		Hallways of hotels/motels , multi-family, dormitory, and senior housing				0.25
		Commercial and Industrial Storage stack areas (max. 2 aisles per sensor)				0.15
		Library Stacks (maximum 2 aisles per sensor)				0.15
Dimming system	Manual	Hotels/motels, restaurants, auditoriums, theaters				0.10
	Multiscene programmable	Hotels/motels, restaurants, auditoriums, theaters				0.20
Demand responsive lighting control that reduces lighting power consumption in response to a demand response signal. (See Note 1)		All buildings types not required to meet Section 130.1(e)				0.05
Manual dimming of dimmable electronic ballasts. (see Note 3)		All building types				0.10
Demand responsive lighting control that reduces lighting power consumption in response to a demand response signal when used in combination with manual dimming of dimmable electronic ballasts (see Note 1 and 3).		All buildings types not required to meet Section 130.1(e)				0.15
Combined controls	Multi-level occupant sensor (see Note 2) combined with multi-level circuitry and switching in accordance with Section 146(a)2D combined with automatic multi-level daylighting controls	Any space ≤ 250 square feet within a daylight area and enclosed by floor-to-ceiling partitions, any size classroom, corridor, conference or waiting room. The PAF may be added to the daylighting control credit				0.10
	Manual dimming of dimmable electronic ballasts (see Note 3) when used in combination with a multi-level occupant sensor (see Note 2) combined with multi-level circuitry and switching in accordance with Section 146(a)2D.	Any space ≤ 250 square feet enclosed by floor-to-ceiling partitions; any size classroom, corridor, conference or waiting room				0.25
Automatic multi-level daylighting controls (See Note 1)	Total primary sidelit daylight areas less than 2,500 ft ² in an enclosed space and all secondary sidelit areas. (see Note 4)	Effective Aperture				
		General Lighting Power Density (W/ft ²)	>10% and ≤20%	>20% and ≤35%	>35% and ≤65%	> 65%
		All	0.12	0.20	0.25	0.30
	Total skylit daylight areas in an enclosed space less than 2,500 square feet, and where glazing material or diffuser has ASTM D1003 haze measurement greater than 90%	Effective Aperture				
		General Lighting Power Density (W/ft ²)	0.6% ≤ EA < 1%	1% ≤ EA < 1.4%	1.4% ≤ EA < 1.8%	1.8% ≤ EA
		LPD < 0.7	0.24	0.30	0.32	0.34
		0.7 ≤ LPD < 1.0	0.18	0.26	0.30	0.32
		1.0 ≤ LPD < 1.4	0.12	0.22	0.26	0.28
		1.4 ≤ LPD	0.08	0.20	0.24	0.28

NOTES FOR TABLE 146-C:

1. PAFs shall not be available for lighting controls required by Title 24, Part 6.
2. To qualify for the PAF the multi-level occupant sensor shall comply with the applicable requirements of Section 119.
3. To qualify for the PAF all dimming ballasts for T5 and T8 linear fluorescent lamps shall be electronic and shall be certified to the Commission with a minimum RSE in accordance with Table 146-D.
4. If the primary sidelit daylight area and the secondary sidelit daylight area are controlled together, the PAF is determined based on the secondary sidelit effective aperture for both the primary sidelit daylight area and the secondary sidelit daylight area.

4.1.4 NA7.6.5 Demand Responsive Lighting Controls Acceptance***NA7.6.5.1 Construction Inspection*****Prior to Functional testing, verify and document the following:**

- **That the demand responsive control is capable of receiving a demand response signal directly or indirectly through another device.**
- **If the demand response signal is received from another device (such as an EMCS), that system must itself be capable of receiving a demand response signal from a utility meter or other external source.**

NA7.6.5.2 Functional testing of Demand Responsive Lighting Controls

For buildings with up to seven (7) enclosed spaces requiring demand responsive lighting controls, all spaces shall be tested. For buildings with more than seven (7) enclosed spaces requiring demand responsive lighting controls, sampling may be done on additional spaces with similar lighting systems. If the first enclosed space with a demand responsive lighting control in the sample group passes the acceptance test, the remaining building spaces in the sample group also pass. If the first enclosed space with a demand responsive lighting control in the sample group fails the acceptance test the rest of the enclosed spaces in that group must be tested. If any tested demand responsive lighting control system fails it shall be repaired, replaced or adjusted until it passes the test.

Test the reduction in lighting power due to the demand responsive lighting control using one or the following two methods.

Method 1: Illuminance Measurement. Measure the reduction in illuminance in enclosed spaces required to meet Section 131(b), as follows:

- **In each space, select one location for illuminance measurement. The chosen location must not be in a primary skylit or sidelit area. When placed at the location, the illuminance meter must not have a direct view of a window or skylight. If this is not possible, perform the test at a time and location at which daylight illuminance provides less than half of the design illuminance. Mark each location to ensure that the illuminance meter can be accurately located.**
- **Full output test**
 - **Using the manual switches/dimmers in each space, set the lighting system to full output. Note that the lighting in areas with photocontrols or occupancy/vacancy sensors may be at less than full output, or may be off.**

- Take one illuminance measurement at each location, using an illuminance meter.
- Simulate a demand response condition using the demand responsive control.
- Take one illuminance measurement at each location with the electric lighting system in the demand response condition.
- Calculate the area-weighted average reduction in illuminance in the demand response condition, compared with the full output condition. The area-weighted reduction must be at least 15% but must not reduce the combined illuminance from electric light and daylight to less than 50% of the design illuminance in any individual space.
- Minimum output test
 - Using the manual switches/dimmers in each space, set the lighting system to minimum output (but not off). Note that the lighting in areas with photocontrols or occupancy/vacancy sensors may be at more than minimum output, or may be off.
 - Take one illuminance measurement at each location, using an illuminance meter.
 - Simulate a demand response condition using the demand responsive control.
 - Take one illuminance measurement at each location with the electric lighting system in the demand response condition.
 - In each space, the illuminance in the demand response condition must not be less than the illuminance in the minimum output condition or 50% of the design illuminance, whichever is less.
 - EXCEPTION: In daylight spaces, the illuminance in the demand response condition may reduce below the minimum output condition, but in the demand response condition the combined illuminance from daylight and electric light must be at least 50% of the design illuminance.

Method 2: Current measurement. Measure the reduction in electrical current in spaces required to meet Section 131(b), as follows:

- At the lighting circuit panel, select at least one lighting circuit that serves spaces required to meet Section 131(b).
- Full output test
 - Using the manual switches/dimmers in each space, set the lighting system to full output. Note that the lighting in areas with photocontrols or occupancy/vacancy sensors may be at less than full output, or may be off.
 - Take one electric current measurement for each selected circuit.
 - Simulate a demand response condition using the demand responsive control.
 - Take one electric current measurement for each selected circuit with the electric lighting system in the demand response condition.

- **Add together all the circuit currents, and calculate the reduction in current in the demand response condition, compared with the full output condition. The combined reduction must be at least 15% but must not reduce the output of any individual circuit by more than 50%.**
- **Minimum output test**
 - **Using the manual switches/dimmers in each space, set the lighting system to minimum output (but not off). Note that the lighting in areas with photocontrols or occupancy/vacancy sensors may be at more than minimum output, or may be off.**
 - **Take one electric current measurement for each selected circuit.**
 - **Simulate a demand response condition using the demand responsive control.**
 - **Take one electric current measurement for each selected circuit with the electric lighting system in the demand response condition.**
 - **In each space, the electric current in the demand response condition must not be less than 50% or the electric current in the minimum output condition, whichever is less.**
 - **EXCEPTION: Circuits that supply power to the daylit portion of enclosed spaces as long as lighting in non-daylit portions of the space are providing at least their minimum light output (but not off).**

5. Bibliography and Other Research

- California Energy Commission. 2006. *California Commercial End-Use Survey Final Report* (Report number CEC-400-2006-005). Prepared by Itron, Inc. for the California Energy Commission. Published 2006. Retrieved November 2010 from <http://www.energy.ca.gov/ceus/>.
- California Energy Commission. 2010. "NonRes Construction Forecast by BCZ v7"; Developed by Heshcong Mahone Group with data sourced September, 2010 from Sheridan, Margaret at the California Energy Commission (CEC).
- Commercial Building Energy Consumption Survey (CBECS). 2006. "Table A6. Building Size, Floorspace for All Buildings (Including Malls)"; Source: Energy Information Administration, Office of Energy Markets and End Use, Form EIA-871A of the 2003 Commercial Buildings Energy Consumption Survey. Retrieved February 2010 from http://www.eia.gov/emeu/cbecs/cbecs2003/detailed_tables_2003/detailed_tables_2003.html.
- DEER, 2005. Database of Energy Efficient Resources (DEER) final report. Prepared by Itron, Inc. for the California Energy Commission (CEC) and California Public Utilities Commission (CPUC). Published 2005. Updated 2008 by CPUC.
- G.R. Newsham, S Mancini, and R.G. Marchand. Detection and acceptance of demand-responsive lighting in office with and without daylight. National Research Council Canada, 2008. <http://www.nrc-cnrc.gc.ca/obj/irc/doc/pubs/nrcc50324/nrcc50324.pdf>.
- Granderson, J. , Piette, M.A. , Ghatikar, G. , Price, P. , (2009). Preliminary Findings from an Analysis of Building Energy Information System Technologies. Lawrence Berkley National Laboratory (LBNL-2224E).
- Grover, Stephen. ECONorthwest. Process Evaluation of the 2006-2008 Statewide Technical Assistance and Technology Incentive Program: Supplementary Evaluation for PY2008. Final Report Study ID SDG0242.01. March 8, 2010.
- Hatley, D.D. , Meador, R.J. , Katipamula, S. , Brambley, M.R. , Wouden, Carl. (2005). Energy Management and Control System: Desired Capabilities and Functionality. Pacific Northwest National Laboratory (PNNL-15074).
- Heshcong Mahone Group. (2009). High Efficiency Office Low Ambient/Task Lighting: Large Office. Pacific Gas & Electric Company (PGE 0819). <http://www.etcc-ca.com/component/content/article/21/2892-high-efficiency-office-low-ambienttask-lighting-large-office->
- Heshcong Mahone Group. (2009). Oregon Lighting Market Assessment. Prepared by Heshcong Energy Trust of Oregon (ETO 0911).
- LRC (Lighting Research Center). 2003. *Reducing Barriers to the Use of High Efficiency Lighting Systems. Final Report: Year 2.* <http://www.lrc.rpi.edu/researchAreas/reducingBarriers/pdf/year2FinalReport.pdf>
- Newsham, G.R. "The role of dimmable lighting in demand-responsive buildings." *Lighting design + application : LD + A*. 39, no. 4 (04 2009): 30-32, 34, 36.

Newsham, G.R., S. Mancini, and R.G. Marchand. "Detection and acceptance of demand-responsive lighting in offices with and without daylight." *Leukos* 4, no. 3 (Jan 2008): 130-156.

"NonRes Construction Forecast by BCZ v7"; Developed by Heschong Mahone Group with data sourced August, 2010 from Abrishami, Moshen at the California Energy Commission (CEC)

PG&E (Pacific Gas & Electric). 2007. Demand Responsive Controls for Indoor Lighting. http://www.energy.ca.gov/title24/2008standards/prerulemaking/documents/2007-02-26-27_workshop/supporting/2007-02-15_REPORT_DEMAND_RESPONSIVE_CONTRLOS_INDOOR_LIGHTNG.PDF

PG&E (Pacific Gas & Electric). 2009. High Efficiency Office Low Ambient/Task lighting: Large Office. PGE 0819. <http://www.etcc-ca.com/component/content/article/21/2892-high-efficiency-office-low-ambienttask-lighting-large-office->

Roth, Kurt W., Westphalen, Detlef, Feng, Michael Y., Llana, Patricia, Quartararo, Lous, (2005). Energy Impact of Commercial Building Controls and Performance Diagnostics: Market Characterization, Energy Impact of Building Faults and Energy Savings Potential. U.S. Department of Energy (DOE-50528).

RS Means. 2010. CostWorks Online Construction Cost Data. Reed Construction Data. <https://www.meanscostworks.com>. Accessed January 2011.

Rubinstein, F., Kiliccote, S., (2007). Demand Responsive Lighting: A Scoping Study. Lawrence Berkley National Laboratory (LBNL-62226).

6. Appendix A--Prototype Building Layouts

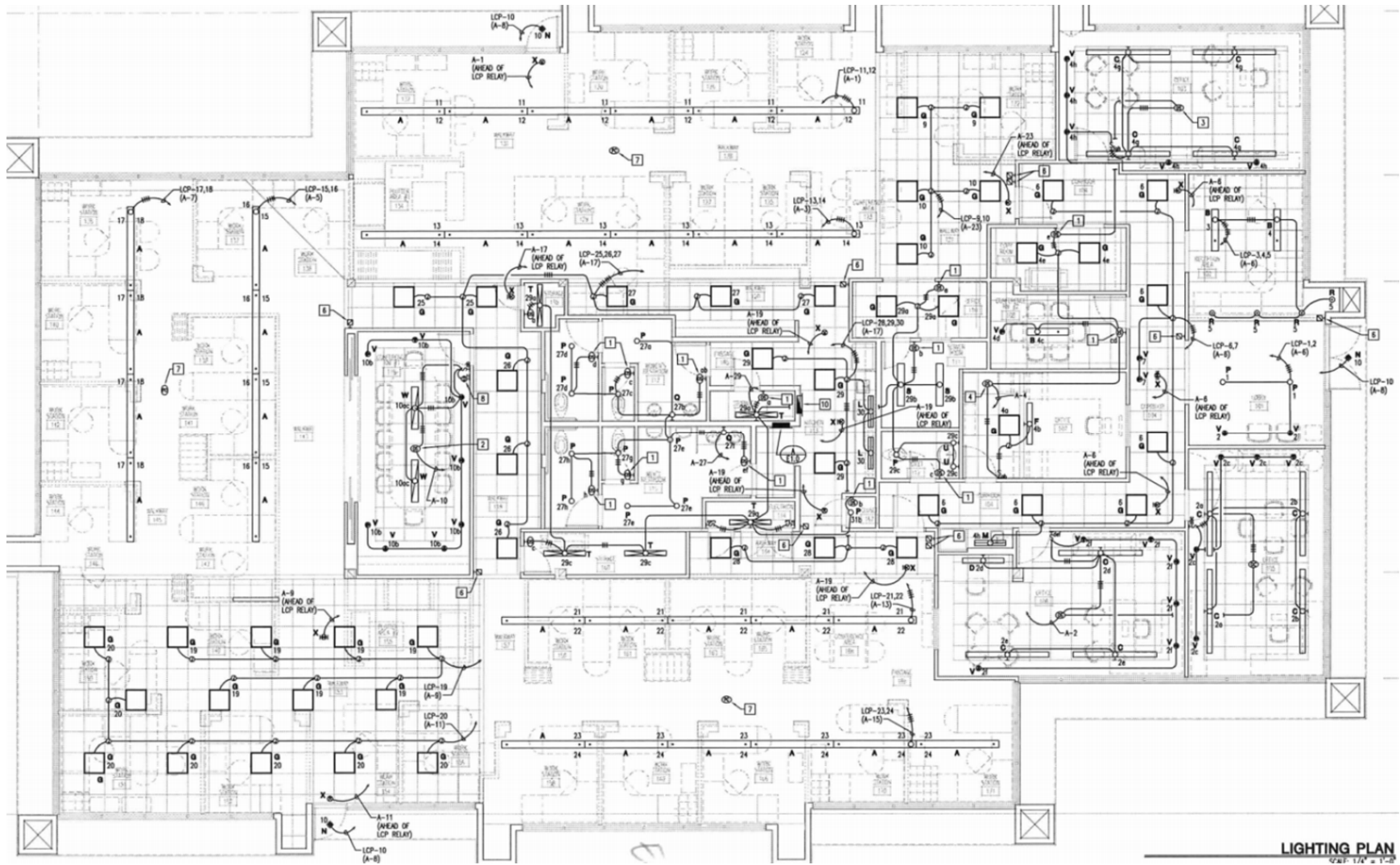
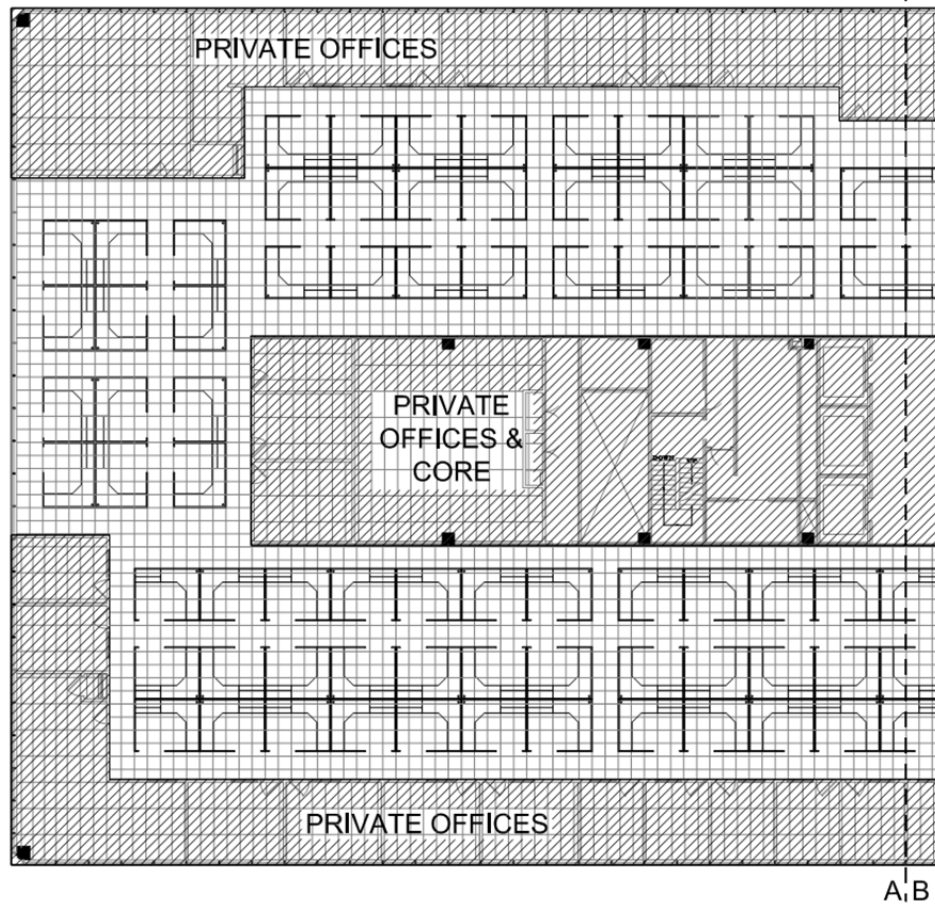

Figure 14 Small office prototype building reflected ceiling and floor plan



LEGEND

<p>KEY MAP</p>	<p>NORTH</p>	<p>ORIGINAL SCALE: 1/16"=1'-0"</p>	<p>CLANTON & ASSOCIATES LIGHTING DESIGN AND ENGINEERING <small>10000 W. CENTRAL EXPRESSWAY, SUITE 100 LOS ANGELES, CALIFORNIA 90024 (310) 552-1111</small></p>	<p>TITLE 24 BASELINE CUBICLE LAYOUT TITLE 24 2011: OPEN OFFICE LIGHTING</p>	<p>Drawing No. SK-0A Date: 09-13-10</p>
----------------	--------------	------------------------------------	---	---	--

Figure 15 West Wing of Large Office Prototype Floor Plan

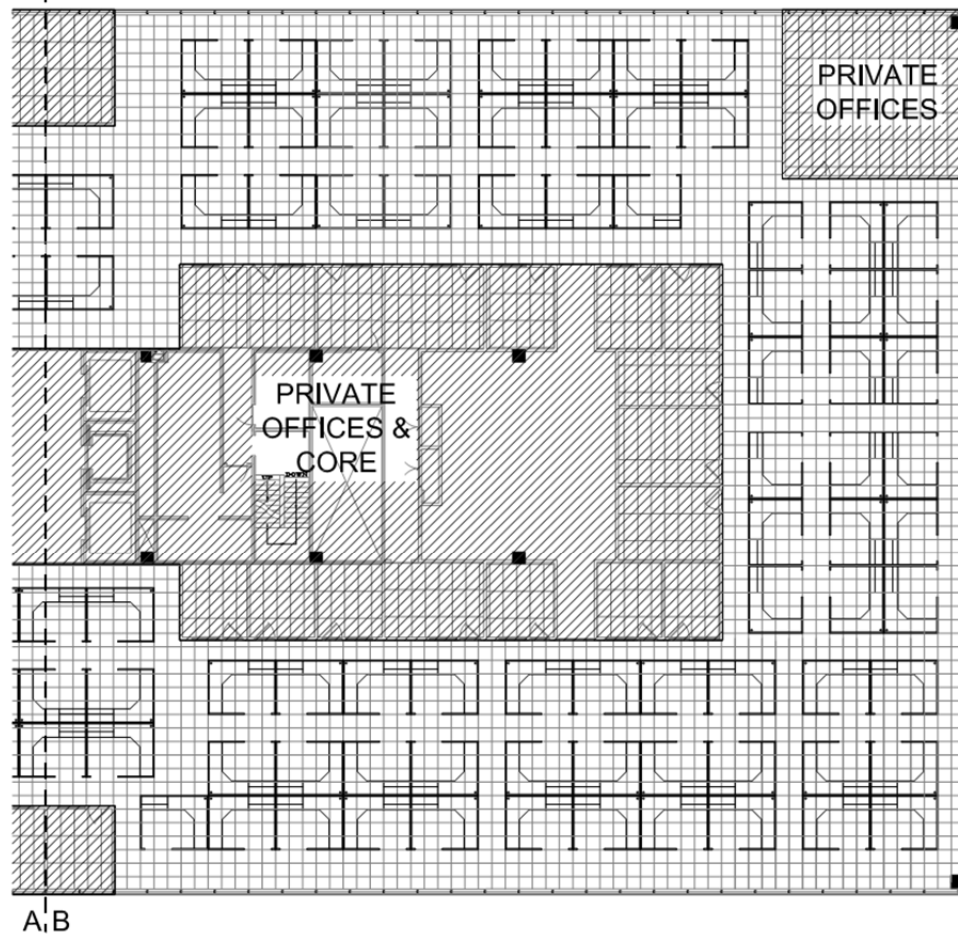

<p>KEY MAP</p>	<p>NORTH</p>	<p>ORIGINAL SCALE: 1/16"=1'-0"</p>	<p>CLANTON & ASSOCIATES</p> <p>LIGHTING DESIGN AND ENGINEERING</p> <p>1000 W. COLORADO AVENUE, SUITE 100 PUEBLO, COLORADO 81001 (303) 733-1111</p>	<p>TITLE 24 BASELINE CUBICLE LAYOUT TITLE 24 2011: OPEN OFFICE LIGHTING</p>	<p>Drawing No. SK-0B Date: 09-13-10</p>
----------------	--------------	------------------------------------	---	---	--

Figure 16 East Wing of Large Office Prototype Floor Plan

7. Appendix B—Controllable Lighting Technology and Products

There are scenarios for compliance with the controllable lighting requirements that would already include demand response capabilities. Several higher end lighting control systems currently on the market include demand response functionality as a standard feature. There are several addressable lighting systems that run on a dedicated server. These are relatively rare in smaller project, but can be found in larger buildings, generally larger than 50,000 sf. In the absence of a dedicated server, some of these addressable systems are controlled by local nodes, which are capable of enabling or disabling "Load Shed" mode using a maintained closure (dry-contact or solid state output).

Compliance options include the use of Ethernet or serial ports that can receive standard building automation communication protocols. There is at least one commercially available controller that can function as a standalone Demand Response Automation Server (DRAS) client. It can be wired into a control panel via Ethernet, or a serial port for networking to a common building communication protocol, such as ModBus¹⁴, DNP3¹⁵, or SNMP¹⁶. It also provides discrete outputs that can be wired to relays directly. The layout of this module can be seen in [Figure 17](#). The installation of this piece of hardware would not be required specifically by the code language. However, the lighting system would need to be ready to receive demand response signals from a similar sort of device. Several major manufacturers of lighting controls indicated during interviews that they are planning to include a similar capability in some of their product lines in the near future. A system with built-in functionality enabling participation in DR programs would also meet the proposed requirements.

There are other addressable lighting network solutions that use a control panel to serve the purpose of both breaker and relay control. This type of system requires a 0-10V module to enable control of dimmable ballasts. This module would be networked onto the system using an Ethernet-type of cable. The controller head end itself can communicate with an energy management control system (EMCS), connect to a third party Auto-DR module like the one depicted in [Figure 17](#), or receive dry contact inputs directly from another source. In higher end models, the control panel may have the capability of being connected directly to the internet via an Ethernet connection.

¹⁴ <http://www.modbus.org/faq.php>

¹⁵ <http://www.dnp.org/About/Default.aspx>

¹⁶ <http://www.net-snmp.org/>

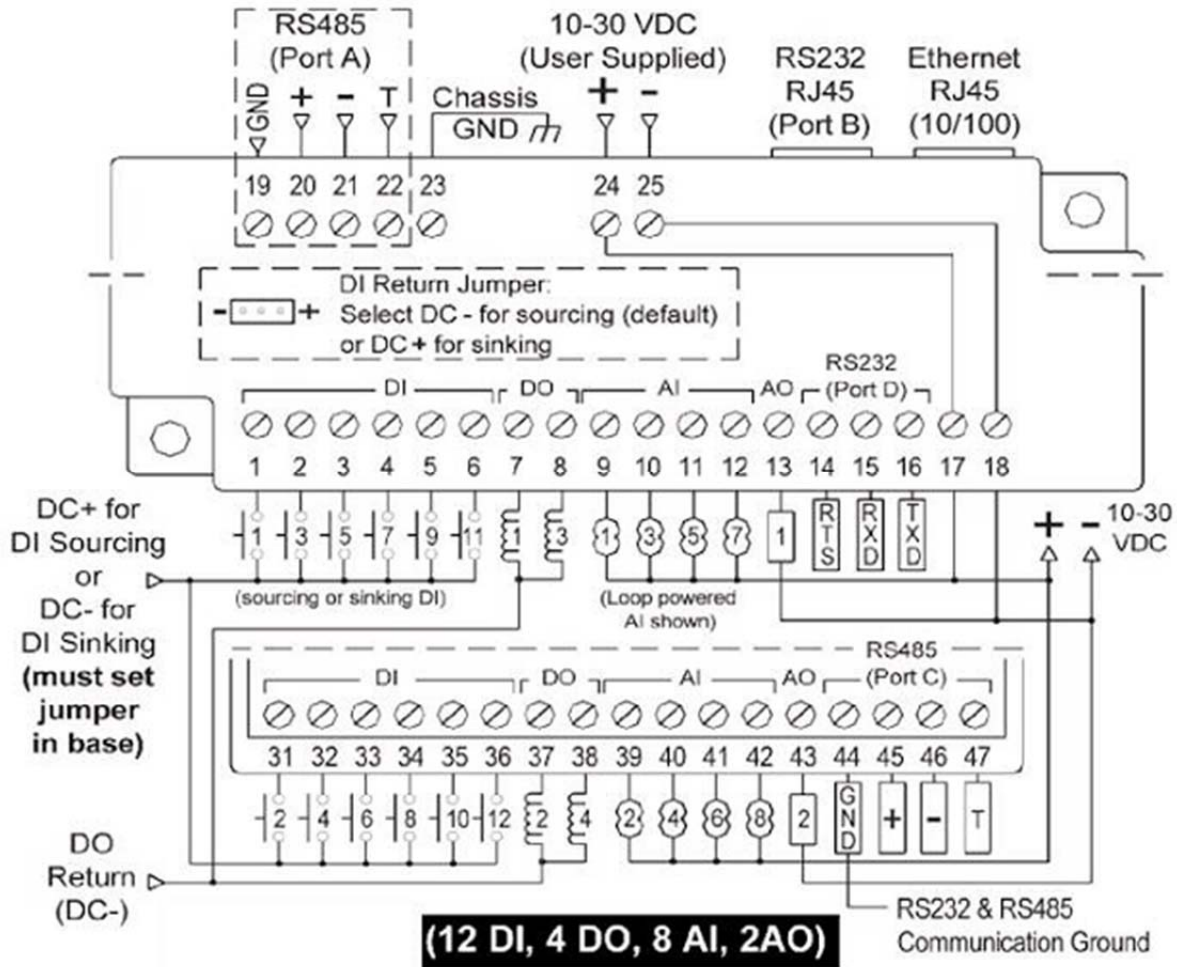

Figure 17 Diagram of third party Auto-DR module inputs and outputs

A zone based lighting control system that allows for scalability allows individual rooms to be added to a controllable EMCS network via proprietary network bridge adapters. This particular scenario would enable the lighting control system to communicate with and respond to commands sent by the EMCS. This type of system makes sense if there is an existing EMCS in place and each adapter would connect to it to add lighting as another end use to be controlled for DR.

8. Appendix C -- Non-Residential Construction Forecast details

8.1 Summary

The Non-Residential construction forecast dataset is data that is published by the California Energy Commission's (CEC) demand forecast office. This demand forecast office is charged with calculating the required electricity and natural gas supply centers that need to be built in order to meet the new construction utility loads. Data is sourced from Dodge construction database, the demand forecast office future generation facility planning data, and building permit office data.

All CASE reports should use the statewide construction forecast for 2014. The TDV savings analysis is calculated on a 15 or 30 year net present value, so it is correct to use the 2014 construction forecast as the basis for CASE savings.

8.2 Additional Details

The demand generation office publishes this dataset and categorizes the data by demand forecast climate zones (FCZ) as well as building type (based on NAICS codes). The 16 climate zones are organized by the generation facility locations throughout California, and differ from the Title 24 building climate zones (BCZ). HMG has reorganized the demand forecast office data using 2000 Census data (population weighted by zip code) and mapped FCZ and BCZ to a given zip code. The construction forecast data is provided to CASE authors in BCZ in order to calculate Title 24 statewide energy savings impacts. Though the individual climate zone categories differ between the demand forecast published by the CEC and the construction forecast, the total construction estimates are consistent; in other words, HMG has not added to or subtracted from total construction area.

The demand forecast office provides two (2) independent data sets: total construction and additional construction. Total construction is the sum of all existing floor space in a given category (Small office, large office, restaurant, etc.). Additional construction is floor space area constructed in a given year (new construction); this data is derived from the sources mentioned above (Dodge, Demand forecast office, building permits).

Additional construction is an independent dataset from total construction. The difference between two consecutive years of total construction is not necessarily the additional construction for the year because this difference does not take into consideration floor space that was renovated, or repurposed.

In order to further specify the construction forecast for the purpose of statewide energy savings calculation for Title 24 compliance, HMG has provided CASE authors with the ability to aggregate across multiple building types. This tool is useful for measures that apply to a portion of various building types' floor space (e.g. skylight requirements might apply to 20% of offices, 50% of warehouses and 25% of college floor space).

The main purpose of the CEC demand forecast is to estimate electricity and natural gas needs in 2022 (or 10-12 years in the future), and this dataset is much less concerned about the inaccuracy at 12 or 24 month timeframe.

It is appropriate to use the CEC demand forecast construction data as an estimate of future years construction (over the life of the measure). The CEC non-residential construction forecast is the best publicly available data to estimate statewide energy savings.

8.3 Citation

“NonRes Construction Forecast by BCZ v7”; Developed by Heschong Mahone Group with data sourced August, 2010 from Abrishami, Moshen at the California Energy Commission (CEC)