

Pipe Sizing, Monitoring, and Leak Testing for Compressed Air Systems – Results Report

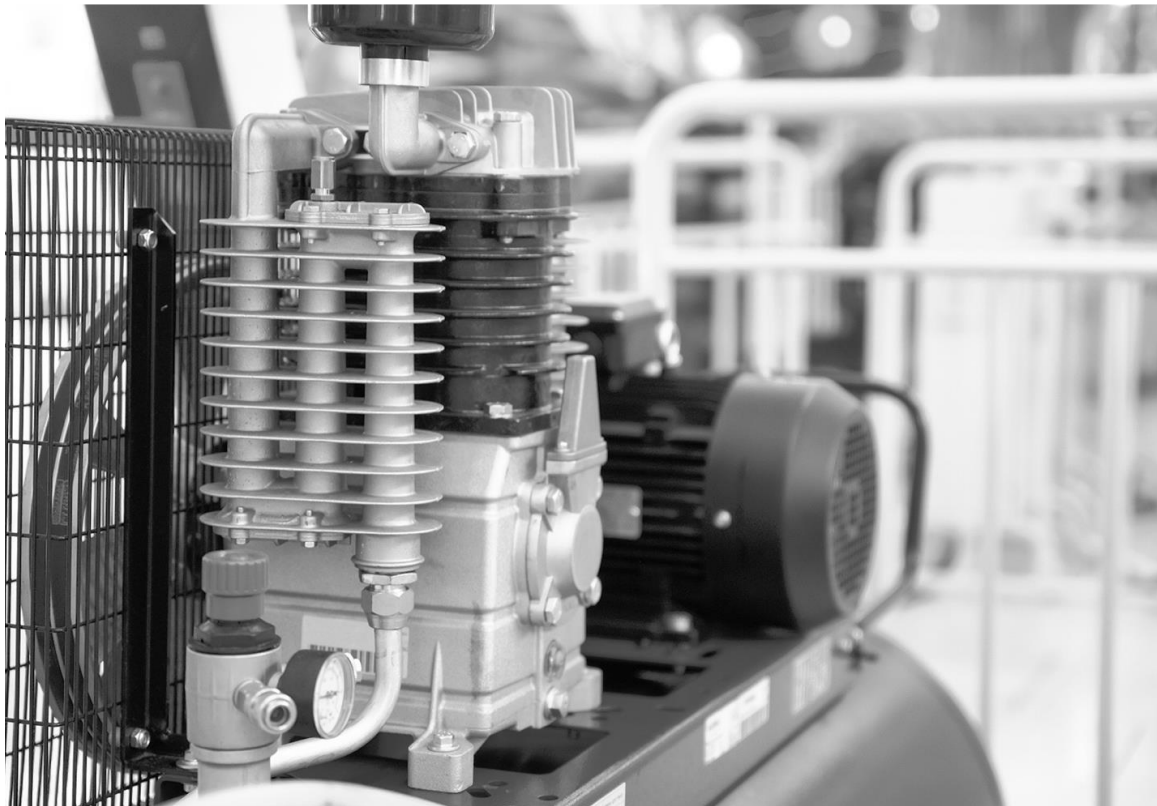

Measure ID: 2022-NR-COV-PROC1-F
Nonresidential Covered Processes

December 2022



This report was prepared by the California Statewide Codes and Standards Enhancement (CASE) Program that is funded, in part, by California utility customers under the auspices of the California Public Utilities Commission.

Copyright 2022 Pacific Gas and Electric Company, Southern California Edison, San Diego Gas & Electric Company, Los Angeles Department of Water and Power, and Sacramento Municipal Utility District. All rights reserved, except that this document may be used, copied, and distributed without modification.

Neither Pacific Gas and Electric Company, Southern California Edison, San Diego Gas & Electric Company, Los Angeles Department of Water and Power, Sacramento Municipal Utility District or any of its employees makes any warranty, express or implied; or assumes any legal liability or responsibility for the accuracy, completeness or usefulness of any data, information, method, product, policy or process disclosed in this document; or represents that its use will not infringe any privately-owned rights including, but not limited to, patents, trademarks or copyrights.



Document Information

Category:	Codes and Standards
Keywords:	Statewide Codes and Standards Enhancement (CASE) Initiative, Statewide Utility Codes and Standards Team, Codes and Standards Enhancements, 2022 Title 24, Part 6, efficiency, compressed air; air compressor; industrial; covered processes; building energy efficiency standards; pneumatic; energy monitoring; key performance indicators; manufacturing; production efficiency
Authors:	M M Valmiki, PE (AESC, Inc.) Kiri Coakley (Energy Solutions)
Prime Contractor	Energy Solutions
Project Management:	California Utilities Statewide Codes and Standards Team: Pacific Gas and Electric Company, Southern California Edison, San Diego Gas & Electric Company, Los Angeles Department of Water and Power, and Sacramento Municipal Utility District

Table of Contents

1. Introduction	1
2. Measure Description	1
2.1 Summary of Adopted Requirements	1
2.2 Summary of Proposed Requirements That Were Not Adopted	5
3. Statewide Energy Impacts of Adopted Requirements	5
4. Compliance and Enforcement	5
5. Interactions with Existing Regulations	6
6. Evolution of Code Requirements	6
6.1 Editorial Revisions	6
6.2 Compliance Manual Development	6
7. Adopted Code Language	7
7.1 California Energy Code, Title 24, Part 6	7
8. Bibliography	11
Attachment 1: Public Comments Submitted by the Statewide CASE Team	12
Attachment 2: Final CASE Report	1189

List of Tables

Table 1: Scope of Adopted Code Changes	5
Table 2: Estimated Statewide First Year ^a Energy and Water Savings	5

1. Introduction

The Codes and Standards Enhancement (CASE) Initiative presents recommendations to support the California Energy Commission’s (CEC) efforts to update the California Energy Code (Title 24, Part 6) to include new requirements or to upgrade existing requirements for various technologies. Three California Investor Owned Utilities (IOUs) – Pacific Gas and Electric Company, San Diego Gas and Electric, and Southern California Edison – and two Publicly Owned Utilities – Los Angeles Department of Water and Power, and Sacramento Municipal Utility District (herein referred to as the Statewide CASE Team when including the CASE Author) – sponsored this effort. The program goal is to prepare and submit proposals that will result in cost-effective enhancements to improve energy efficiency and energy performance in California buildings to the CEC, the state agency that has authority to adopt revisions to Title 24, Part 6. The CEC evaluates proposals submitted by the Statewide CASE Team and other stakeholders and may revise or reject proposals.

In September 2020, the Statewide CASE Team submitted the CASE Report that is presented in Attachment 1 to recommend code changes related to pipe sizing, monitoring, and leak testing for compressed air systems. This document explains the revisions that occurred to the proposed code changes between the submittal of the Final CASE Report to the CEC and the CEC’s adoption of the 2022 Title 24, Part 6 Standards including the Reference Appendices on August 11, 2021. The document begins with a concise description of the adopted code language, followed by the estimated energy savings of the adopted requirements, with the remainder of the document outlining the evolution of the code changes and the final adopted language.

2. Measure Description

2.1 Summary of Adopted Requirements

The sections below summarize recommended changes to the standards, Reference Appendices, and compliance documents that have been adopted.

2.1.1 Changes to Existing Mandatory Requirements for Compressed Air Systems

Several proposed changes to the existing language were adopted exactly as the Statewide CASE Team proposed in the Final CASE Report. These changes were designed to simplify the existing language, address some confusing terms, and align the existing code with new adopted subsections. The Statewide CASE Team was able to

support the CEC decision-making process such that all the proposed changes were adopted without modification.

Because the term “online” is not an industry-standard term or universally definable for covered compressed air situations, the adopted changes included removal of the word from Section 120.6(e). This change helps avoid confusion in compliance and coverage by eliminating terminology ambiguity reported by stakeholders. The existing stringency was kept intact by adjusting the existing controls requirements language to cover systems with “three or more compressors.” This adopted change excludes coverage of systems with a redundant or backup compressor, as was the original intent of using the term “online.”

Also adopted as proposed was the relocation of Exception 1 to Section 120.6(e). The original location exempted alterations of existing compressed air systems with centrifugal compressors. This exception was moved from the overall section 120.6(e) to the existing subsection 120.6(e)1. This change ensured that original control requirements and the new requirements apply to systems with centrifugal compressors. This was necessary since only the trim requirement has particularly prohibitive barriers with existing centrifugal compressors and the new adopted subsections are applicable and feasible regardless of compressor type.

A modification to Exception 2 to Section 120.6(e) was also adopted as proposed in the Final CASE Report. The original exception to 120.6(e) exempted all compressed air systems in healthcare facilities when the only exempted systems should be critical medical gas systems. Since healthcare facilities often have non-medical gas compressed air systems that should be covered, the language was modified so the compressed air requirements apply to healthcare except for medical gas compressed air systems. This change ensured coverage of process compressed air unrelated to life-support and medically-critical loads. The CEC adopted the code as proposed based on feedback from California’s Department of Health Care Access and Information, formerly known as the Office of Statewide Health Planning and Development (OSHPD).

The CEC adopted the proposed changes to exceptions in Section 120.6(e)1 – Trim Compressor and Storage. The changes mitigated any effects of removing the term “online”, which may have had the negative effect of increasing stringency of the existing trim compressor requirement without mitigating language. Additionally, an exception for alterations that include new variable speed compressors and sufficient storage was added since that type of compressor will inherently provide additional trim capacity.

The last adopted change to the existing language was a slight change in specificity in Section 120.6(e)2 – Controls. The language was modified to simplify, avoid confusion, and align the code language with commercially-available control products, and to ensure that controls can operate in response to demand as determined by any industry-standard method instead of “based on the current air demand as measured by a

sensor.” This change ensured that industry-standard control methods can be used without concern or confusion over code language that previously could be interpreted as requiring direct airflow measurements. This was necessary since stakeholders had expressed concern and confusion over the meaning of the existing language that is in conflict with typical controller capabilities and best practices.

2.1.2 Section 120.6(e)3 – Monitoring

The CEC adopted the proposed language for the new monitoring subsection without changes. This new subsection requires metering and monitoring of key performance indicators of a compressed air system’s supply and demand. The required monitoring points include system pressure, compressor power or amps, airflow, and system efficiency. The requirement provides facility operators insight into their system’s energy consumption, performance, and demand characteristics.

This change was important because compressed air users typically have little-to-no insight into the compressor system performance and do not often have justification or visible reasons to maintain system efficiency. The monitoring requirement directly addresses the primary barriers to continuous system improvement and maintenance by providing insight, visibility, accountability, and enabling quantification of cost and energy benefits. The Statewide CASE Team and the CEC had extensive discussions on the merits and justification of the behavioral-dependent measure. Stakeholder feedback and available published research on the technology was instrumental in the CEC ultimately adopting of the proposed language without changes.

2.1.3 Section 120.6(e)4 Leak Testing of Compressed Air Piping

This new subsection requires leak testing to ensure quality installation of new compressed air piping. The purpose of this new requirement is to ensure piping installers are following industry standard best practices for piping installation and commissioning. This is important because new piping should be absent of leaks that would then be difficult or impossible to address after start-up and that could last for the life of the plant. Beyond energy savings, this will benefit facility operations by ensuring long-term system reliability and compressed air availability.

The proposed language for leak testing of new piping was adopted with one change. The section relies upon test language from the California Plumbing Code. The proposal in the Final CASE Report reiterated the instrumentation requirements in the plumbing code word-for-word so that market actors would not have to look up the separate code for pressure gauge requirements. However, the CEC decided that the Title 24, Part 6 language should simply reference the plumbing code section instead of rewriting the reference language. This change will ensure that any future changes to the plumbing

code will automatically pass through to Title 24, Part 6. Otherwise, the proposed language was adopted as proposed and the intent and scope are unaffected.

2.1.4 Section 120.6(e)5 – Pipe Sizing

The proposed language for compressed air piping was adopted without changes. This new subsection requires proper sizing of compressed air piping at design and construction phases, per typical best practice guidelines. The purpose of this is to minimize pressure losses in undersized piping which then require compressors to run at avoidably high pressure setpoints, therefore using more energy to overcome the avoidable losses. This is important because systems can be undersized due to poor adherence to design practices or cost-cutting efforts associated with pipe material and installation costs. Once installed, piping frictional pressure losses will be present for the life of the system and should be avoided upfront with proper pipe sizing practices.

2.1.5 Summary of Changes to the Reference Appendices

Section NA7.13 of the Reference Appendices was amended with a new monitoring functional test. The proposed language from the Final CASE Report was adopted without changes.

2.1.6 Summary of Changes to the Nonresidential Compliance Manual

The Final CASE Report did not include any suggested changes to the Nonresidential Compliance Manual. However, the Statewide CASE Team did work with CEC to recommend revisions to the Nonresidential Compliance Manual after publishing the Final CASE Report. The proposed content for Section 10.8 of the Nonresidential Compliance Manual includes clarifying examples of covered situations for the new adopted sections. Additionally, the proposal includes modifications of the existing examples to match the clean-up efforts for existing language.

2.1.7 Summary of Changes to Compliance Documents

The code changes require modification of some compliance documentation (NRCI-PRC-01-E and NRCA-PRC-01-F) but should not require any new forms. At the time this report was published, these CEC is still finalizing these compliance forms.

2.1.8 Scope of Code Change Proposal

Table 1 identifies sections of the Standards and Reference Appendices that were modified due to advocacy activities and whether compliance software will be updated.

Table 1: Scope of Adopted Code Changes

Measure Name	Type of Requirement	Modified Section(s) of Title 24, Part 6	Modified Title 24, Part 6 Appendices	Will Compliance Software Be Modified?
Pipe Sizing	Mandatory (New Construction)	Section 120.6(e)	N/A	No
Leak Monitoring	Mandatory (New Construction, Additions and Alterations)	Section 120.6(e)	NA7.13	No
Leak Testing	Mandatory (New Construction, Additions and Alterations)	Section 120.6(e)	N/A	No

2.2 Summary of Proposed Requirements That Were Not Adopted

All of the Statewide CASE Team’s proposed requirements were adopted by the CEC.

3. Statewide Energy Impacts of Adopted Requirements

Table 2 shows the estimated energy savings of the adopted requirements over the first twelve months that are in effect. The first-year savings have not changed since submitting the Final CASE Report.

Table 2: Estimated Statewide First Year^a Energy and Water Savings

Measure	First Year Electricity Savings (GWh/yr)	First Year Peak Electrical Demand Reduction (MW)	First Year Water Savings (million gallons/yr)	First Year Natural Gas Savings (million therms/yr)
Pipe Sizing	13.6	1.25	N/A	N/A
Leak Monitoring	29.3	3.11	N/A	N/A
Leak Testing	1.4	0.19	N/A	N/A

a. First year savings from all buildings completed statewide in 2023.

4. Compliance and Enforcement

There were no changes to the compliance or enforcement recommendations between the time the Statewide CASE Team submitted the Final CASE Report and the CEC adopted requirements. Compliance and enforcement is discussed in Sections 2.5 and

Appendix E of the Final CASE Report, which is provided in Attachment 2: Final CASE Report.

5. Interactions with Existing Regulations

Section 2.4 of the Final CASE Report describes how the proposed code changes interact with existing regulations. Since CEC adopted the requirements as proposed, the information in the Final CASE Report remains an accurate description of how the adopted requirements interact with existing regulations. See the Final CASE Report in Attachment 2: Final CASE Report.

6. Evolution of Code Requirements

The Statewide CASE Team submitted the Final CASE Report to the CEC during September 2020. The Final CASE Report addresses input that was received during utility-sponsored stakeholder meetings held on September 19, 2019 and November 17, 2019 and during the CEC's pre-rulemaking workshop that was held on September 23, 2020. This section describes how the code change proposal evolved between the time Final CASE Report was submitted to the CEC and the time the standards were adopted.

6.1 Editorial Revisions

During the CEC review of the Final CASE Report, the Statewide CASE Team provided support and explanations to CEC staff when needed through adoption. Although the CEC ultimately adopted all the suggested measures and proposed language, there was one notable editorial change. The proposed language for the leak testing measure was developed, in part, by referencing pressure gauge requirements already existing in the California Plumbing Code. In the Final CASE Report, the Statewide CASE Team proposed language that explicitly included these requirements so that no reference to external documents was needed when one is using Title 24, Part 6. However, the CEC ultimately decided that using an explicit reference to the plumbing code (California Plumbing Code section 318.3, 318.4, and 318.5) was better than spelling out the requirement. This would help avoid having to revise Title 24, Part 6 in the event that the plumbing code section is changed, itself. The Statewide CASE Team agreed with the change since it does not alter the intent of the proposed language.

6.2 Compliance Manual Development

Once the pre-rulemaking process was underway, the Statewide CASE Team developed suggested language and revisions to the Nonresidential Compliance Manual sections

relevant to compressed air measures. Since covered processes and compressed air have many real-world conditions and alternative industry terminology, examples for the new code coverage and application were needed. Additionally, the adopted changes to the existing language also required updates to the existing examples in the compliance manual. The Statewide CASE Team will continue to collaborate with the CEC as the Nonresidential Compliance Manual undergoes revisions during the post-rulemaking efforts.

7. Adopted Code Language

The adopted code language for the standards and Reference Appendices are presented in the following sections. Additions to the 2019 Title 24, Part 6 code language are underlined and deletions are ~~struck~~.

7.1 California Energy Code, Title 24, Part 6

7.1.1 Section 120.6 – Mandatory Requirements for Covered Processes

(e) **Mandatory Requirements for Compressed Air Systems.** All new compressed air systems, and all additions or alterations of compressed air systems where the total combined ~~online~~ horsepower (hp) of the compressor(s) is ~~25 horsepower~~ 25 hp or more shall meet the requirements of Subsections 1 through ~~53~~. These requirements apply to the compressors, related piping systems, and related controls that provide compressed air and do not apply to any equipment or controls that use or process the compressed air.

~~**EXCEPTION 1 to Section 120.6(e):** Alterations of existing compressed air systems that include one or more centrifugal compressors.~~

~~**EXCEPTION 24 to Section 120.6(e):** Compressed Air Systems, including Medical gas compressed air systems, serving healthcare facilities.~~

1. Trim Compressor and Storage. The compressed air system shall be equipped with an appropriately sized trim compressor and primary storage to provide acceptable performance across the range of the system and to avoid control gaps. The compressed air system shall comply with Subsection A or B below:

A. The compressed air system shall include one or more variable speed drive (VSD) compressors. For systems with more than one compressor, the total combined capacity of the VSD compressor(s) acting as trim compressors must be at least 1.25 times the largest net capacity increment between combinations of compressors. The compressed air system shall include primary storage of at least one gallon per actual cubic feet per minute (acfm) of the largest trim compressor; or,

B. The compressed air system shall include a compressor or set of compressors with total effective trim capacity at least the size of the largest net capacity increment between combinations of compressors, or the size of the smallest compressor, whichever is larger. The total effective trim capacity of single compressor systems shall cover at least the range from 70 percent to 100 percent of rated capacity. The effective trim capacity of a compressor is the size of the continuous operational range where the specific power of the compressor (kW/100 acfm) is within 15 percent of the specific power at its most efficient operating point. The total effective trim capacity of the system is the sum of the effective trim capacity of the trim compressors. The system shall include primary storage of at least 2 gallons per acfm of the largest trim compressor.

EXCEPTION 1 to Section 120.6(e)1: ~~Compressed air systems in existing facilities that are adding or replacing less than 50 percent of the online capacity of the system~~
Alterations where the total combined added or replaced compressor horsepower is less than the average per-compressor horsepower of all compressors in the system.

EXCEPTION 2 to Section 120.6(e)1: Alterations where all added or replaced compressors are variable speed drive (VSD) compressors and compressed air system includes primary storage of at least one gallon per actual cubic feet per minute (acfm) of the largest trim compressor.

EXCEPTION 3 to Section 120.6(e)1: Compressed air systems that have been approved by the Energy Commission Executive Director as having demonstrated that the system serves loads for which typical air demand fluctuates less than 10 percent.

EXCEPTION 4 to Section 120.6(e)1: Alterations of existing compressed air systems that include one or more centrifugal compressors.

2. **Controls.** Compressed air systems with three or more than one compressors online, having and a combined horsepower rating of more than 100 hp, must shall operate with ~~a controller that is~~ controls that are able to choose the most energy efficient combination and loading of compressors within the system based on the current compressed air demand as measured by a sensor.

3. **Monitoring.** Compressed air systems having a combined horsepower rating equal to or greater than 100 hp shall have an energy and air demand monitoring system with the following minimum requirements:

A. Measurement of system pressure.

B. Measurement of amps or power of each compressor.

C. Measurement or determination of total airflow from compressors in cfm.

D. Data logging of pressure, power in kW, airflow in cfm, and compressed air system specific efficiency in kW/100 cfm at intervals of 5 minutes or less.

E. Maintained data storage of at least the most recent 24 months.

F. Visual trending display of each recorded point, load, and specific energy.

4. Leak Testing of Compressed Air Piping. Compressed air system piping greater than 50 adjoining feet in length shall be pressure tested after being isolated from the compressed air supply and end uses. The piping shall be pressurized to the design pressure and test pressures shall be held for a length of time at the discretion of the authority having jurisdiction, but in no case for less than 30 minutes, with no perceptible drop in pressure.

If dial gauges are used for conducting this test, these gauges must conform with California Plumbing Code section 318.3, 318.4, and 318.5.

Piping less than or equal to 50 adjoining feet in length shall be pressurized and inspected. Connections shall be tested with a noncorrosive leak-detecting fluid or other leak detecting methods at the discretion of the Authority Having Jurisdiction.

5. Pipe Sizing. Compressed air piping greater than 50 adjoining feet in length shall be designed and installed to minimize frictional losses in the distribution network. These piping installations shall meet the requirements of Section 120.6(e)5A and either Section 120.6(e)5B or 120.6(e)5C:

A. Service line piping shall have inner diameters greater than or equal to $\frac{3}{4}$ inch. Service line piping are pipes that deliver compressed air from distribution piping to end uses.

B. Piping section average velocity. Compressor room interconnection and main header piping shall be sized so that at coincident peak flow conditions, the average velocity in the segment of pipe is no greater than 20 ft/sec. Compressor room interconnection and main header piping are the pipes that deliver compressed air from the compressor outlets to the inlet to the distribution piping. Each segment of distribution and service piping shall be sized so that at coincident peak flow conditions, the average velocity in the segment of pipe is no greater than 30 ft/sec. Distribution piping are pipes that deliver compressed air from the compressor room interconnection piping or main header piping to the service line piping.

C. Piping total pressure drop. Piping shall be designed such that piping frictional pressure loss at coincident peak loads are less than 5 percent of operating pressure between the compressor and end use or end use regulator.

63. Compressed Air System Acceptance. Before an occupancy permit is granted for a compressed air system subject to Section 120.6(e), the following equipment and systems shall be certified as meeting the Acceptance Requirements for Code Compliance, as specified by the Reference Nonresidential Appendix NA7. A Certificate

of Acceptance shall be submitted to the enforcement agency that certifies that the equipment and systems meet the acceptance requirements specified in NA 7.13.

7.1.2 Reference Appendices

NA7.13 Compressed Air System Acceptance Tests

NA7.13.1 Compressed Air Control System

Acceptance tests for compressed air controls in accordance with Section 120.6(e)2.

NA7.13.1.1 Construction Inspection

~~Prior to functional testing, a compressed air system must v~~Verify and document the following prior to functional testing:

- (a) Size (hp), rated capacity (acfm), and control type of each air compressor.
- (b) Total online system capacity (the sum of the individual capacities).
- (c) System operating pressure.
- (d) Compressor(s) designated as trim compressors.
- (e) Method for observing and recording the states of each compressor in the system, which shall include at least the following states:

Off Unloaded

Partially loaded

Fully loaded

Short cycling (loading and unloading more often than once per minute) Blow off (venting compressed air at the compressor itself)

NA7.13.1.2 Functional Testing

Step 1: As specified by the test methods outlined in the Construction Inspection, verify that these methods have been employed, so that the states of the compressors and the current air demand (as measured by a flow sensor or otherwise inferred by system measurements) can be observed and recorded during testing.

Step 2: Run the compressed air supply system steadily at as close to the expected operational load range as can be practically implemented, for a duration of at least 10 minutes.

Step 3: Observe and record the states of each compressor and the current air demand during the test.

Step 4: Confirm that the combinations of compressors states meet the following criteria:

- (a) No compressor exhibits short-cycling (loading and unloading more often than once per minute).
- (b) No compressor exhibits blowoff (venting compressed air at the compressor itself).
- (c) For new systems, the trim compressors shall be the only compressors partially loaded, while the base compressors will either be fully loaded or off by the end of the test.

NA7.13.2 Compressed Air Monitoring

Acceptance tests for compressed air monitoring installed in accordance with Section 120.6(e)3.

NA7.13.2.1 Construction Inspection

Verify and document the following monitoring system capabilities prior to functional testing:

- (a) Measurement of header or compressor discharge pressure.
- (b) Measurement of amps or power of each compressor.
- (c) Measurement or determination of airflow in cfm.
- (d) Data logging of pressure, power, airflow, and calculated compressed air system specific efficiency in kW/100 cfm at intervals of 5 minutes or less.
- (e) Maintained data storage.
- (f) Visual trending display of each recorded point, load, and specific efficiency.

NA7.13.2.2 Functional Testing

Verify and document the following monitoring system capabilities:

- (a) Data observed during test is being recorded to a log file that can be opened and viewed to see trend of airflow, power, and specific efficiency in at least 5 minute intervals.
- (d) Airflow and compressor power data vary with loading and unloading of the compressor within typical performance expectations. Measurements should be observed across various loading, whether manually varied in response to actual operational loads.

8. Bibliography

There were no references necessary for the Results Report. See the Bibliography of the Final CASE Report for additional references used in the proposal development.

Attachment 1: Public Comments Submitted by the Statewide CASE Team

Attachment 1 presents comments that the Statewide CASE Team submitted to the Energy Commission's docket that are relevant to this measure.

- Statewide CASE Team, Docket #21-BSTD-01 TN#238087 “Statewide Utility Codes and Standards Enhancement Team Comments on Outdoor Lighting Controls for 45-Day Language”, 6/1/2021,
<https://efiling.energy.ca.gov/GetDocument.aspx?tn=238087&DocumentContentId=71361>
- Statewide CASE Team, Docket #21-BSTD-01 TN#238404 “Statewide Utility Codes and Standards Enhancement Team Comments on 45-Day Express Terms_Part 1”, 6/21/2021,
<https://efiling.energy.ca.gov/GetDocument.aspx?tn=238404&DocumentContentId=71705>
- Statewide CASE Team, Docket #21-BSTD-01 TN#238406, “Statewide Utility Codes and Standards Enhancement Team Comments -Comments on 45-Day Express Terms_Part 2”, 6/21/2021,
<https://efiling.energy.ca.gov/GetDocument.aspx?tn=238406&DocumentContentId=71707>
- Statewide CASE Team, Docket #21-BSTD-01 TN#238409 “Statewide Utility Codes and Standards Enhancement Team Comments on 45-Day Express Terms_Part 3”, 6/21/2021,
<https://efiling.energy.ca.gov/GetDocument.aspx?tn=238409&DocumentContentId=71710>

Attachment 2: Final CASE Report

The final version of the CASE Report is provided in full in Attachment 2 to this report.

Pipe Sizing, Monitoring, and Leak Testing for Compressed Air Systems

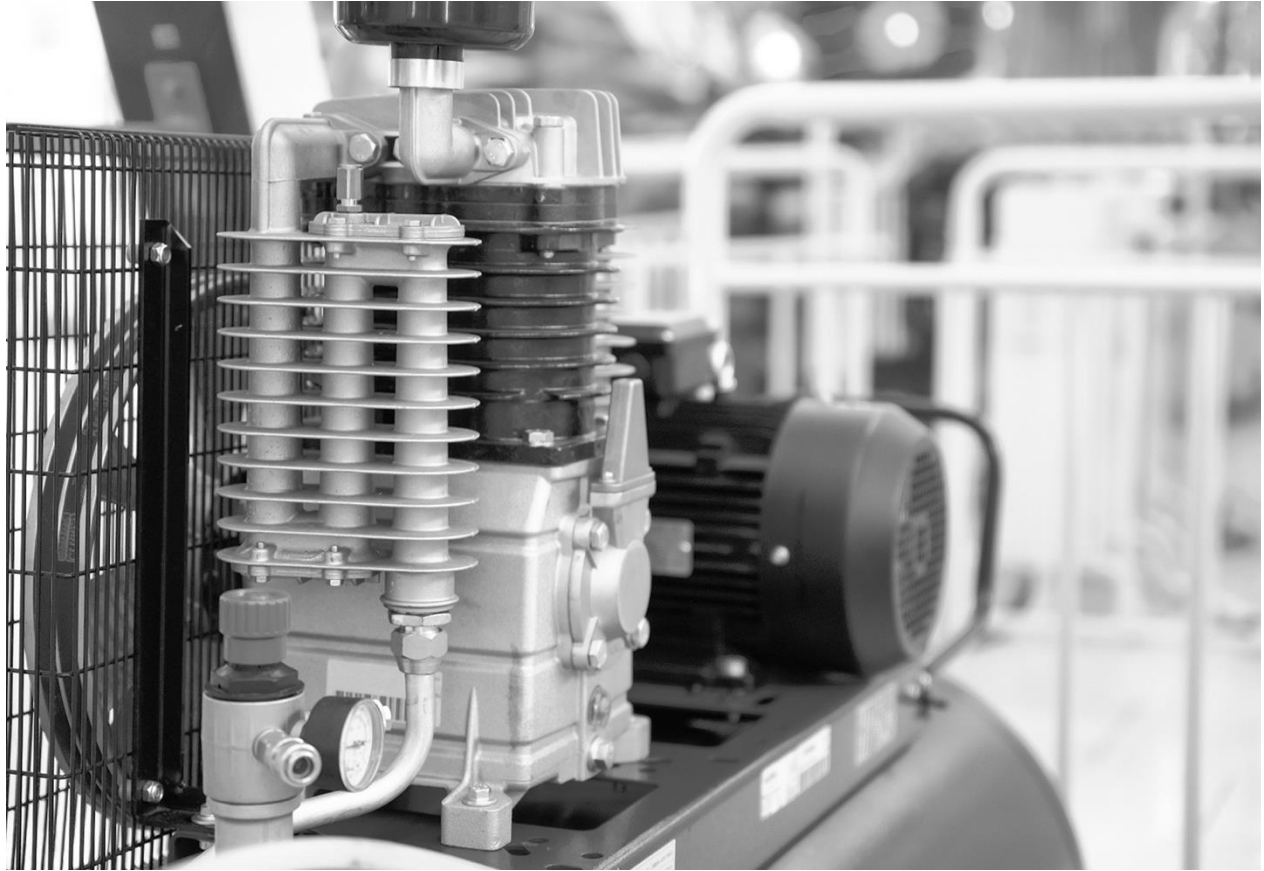

2022-NR-COV-PROC1-F | Nonresidential Covered Processes
Prepared by AESC, Inc. and Energy Solutions

FINAL CASE REPORT
September 2020

Please submit comments to info@title24stakeholders.com.



This report was prepared by the California Statewide Codes and Standards Enhancement (CASE) Program that is funded, in part, by California utility customers under the auspices of the California Public Utilities Commission.

Copyright 2020 Pacific Gas and Electric Company, Southern California Edison, San Diego Gas & Electric Company, Los Angeles Department of Water and Power, and Sacramento Municipal Utility District. All rights reserved, except that this document may be used, copied, and distributed without modification.

Neither Pacific Gas and Electric Company, Southern California Edison, San Diego Gas & Electric Company, Los Angeles Department of Water and Power, Sacramento Municipal Utility District or any of its employees makes any warranty, express or implied; or assumes any legal liability or responsibility for the accuracy, completeness or usefulness of any data, information, method, product, policy or process disclosed in this document; or represents that its use will not infringe any privately-owned rights including, but not limited to, patents, trademarks or copyrights.

Document Information

Category:	Codes and Standards
Keywords:	Statewide Codes and Standards Enhancement (CASE) Initiative; California Statewide Utility Codes and Standards Team; Codes and Standards Enhancements; 2022 California Energy Code; 2022 Title 24, Part 6; efficiency; compressed air; air compressor; industrial; covered processes; building energy efficiency standards; pneumatic; energy monitoring; key performance indicators; manufacturing; production efficiency
Authors:	M M Valmiki, PE, Joseph Ling, PE, Keith Valenzuela, PE, Regina Caluya (AESC, Inc.) Kiri Coakley (Energy Solutions)
Prime Contractor	Energy Solutions
Project Management:	California Statewide Utility Codes and Standards Team: Pacific Gas and Electric Company, Southern California Edison, San Diego Gas & Electric Company, Los Angeles Department of Water and Power, Sacramento Municipal Utility District.

Table of Contents

1. Introduction	15
2. Measure Description	18
2.1 Measure Overview	18
2.2 Measure History	20
2.3 Summary of Proposed Changes to Code Documents	23
2.4 Regulatory Context	26
2.5 Compliance and Enforcement	31
3. Market Analysis	34
3.1 Market Structure	34
3.2 Technical Feasibility, Market Availability, and Current Practices	36
3.3 Market Impacts and Economic Assessments	44
3.4 Economic Impacts	50
4. Energy Savings	59
4.1 Key Assumptions for Energy Savings Analysis	60
4.2 Energy Savings Methodology	61
5. Cost and Cost Effectiveness	82
5.1 Energy Cost Savings Methodology	82
5.2 Energy Cost Savings Results	82
5.3 Incremental First Cost	83
5.4 Incremental Maintenance and Replacement Costs	86
5.5 Cost Effectiveness	87
6. First-Year Statewide Impacts	90
6.1 Statewide Energy and Energy Cost Savings	90
6.2 Statewide Greenhouse Gas (GHG) Emissions Reductions	91
6.3 Statewide Water Use Impacts	92
6.4 Statewide Material Impacts	92
6.5 Other Non-Energy Impacts	93
7. Proposed Revisions to Code Language	94
7.1 Guide to Markup Language	94
7.2 Standards	94
7.3 Reference Appendices	97
7.4 ACM Reference Manual	98
7.5 Compliance Manuals	98
7.6 Compliance Documents	99
8. Bibliography	100

Appendix A : Statewide Savings Methodology	106
Appendix B : Nominal Cost Savings	108
Appendix C : Environmental Impacts Methodology	109
Appendix D : California Building Energy Code Compliance (CBECC) Software Specification	111
Appendix E : Impacts of Compliance Process on Market Actors	112
Appendix F : Summary of Stakeholder Engagement	116

List of Tables

Table 1: Scope of Code Change Proposal	10
Table 2: First-Year Statewide Energy and Impacts	12
Table 3: First-Year Statewide GHG Emissions Impacts	13
Table 4: California Construction Industry, Establishments, Employment, and Payroll	45
Table 5: Specific Subsectors of the California Commercial Building Industry Impacted by Proposed Change to Code	46
Table 6: California Building Designer and Energy Consultant Sectors	47
Table 7: Employment in California State and Government Agencies with Building Inspectors	50
Table 8: Estimated Impact that Adoption of the Proposed Measure would have on the California Commercial Construction Sector – Pipe Sizing	52
Table 9: Estimated Impact that Adoption of the Proposed Measure would have on the California Commercial Construction Sector – Leak Testing	52
Table 10: Estimated Impact that Adoption of the Proposed Measure would have on the California Commercial Construction Sector – Leak Monitoring	53
Table 11: Estimated Impact that Adoption of the Proposed Measure would have on the California Building Designers and Energy Consultants Sectors – Pipe Sizing	53
Table 12: Estimated Impact that Adoption of the Proposed Measure would have on the California Building Designers and Energy Consultants Sectors – Leak Monitoring	54
Table 13: Estimated Impact that Adoption of the Proposed Measure would have on California Building Inspectors – Pipe Sizing	54
Table 14: Estimated Impact that Adoption of the Proposed Measure would have on California Building Inspectors – Leak Testing	55
Table 15: Estimated Impact that Adoption of the Proposed Measure would have on California Building Inspectors – Leak Monitoring	55

Table 16: Net Domestic Private Investment and Corporate Profits, U.S.	57
Table 17: Representative Compressed Air Systems	62
Table 18: Leak Testing and Monitoring Standard Design and Proposed Design Conditions	66
Table 19: Prototype Piping Systems	69
Table 20: Conditions for Pressure Drop Calculations of Each Prototype System	70
Table 21: Standard Design Pressure Drop Calculations for Each Prototype System....	73
Table 22: Proposed Design Pressure Drop Calculations for Each Prototype System...	74
Table 23: Pressure Drop Reduction for Each Prototype System.....	74
Table 24: Loop Piping Pressure Drop Inputs.....	75
Table 25: Loop Piping Pressure Drop Calculation Using 20 Sections	76
Table 26: Velocity of Loop Piping at Actual Pressure (100 psig nominal)	77
Table 27: First-Year Energy Impacts Per Prototype Building – Pipe Sizing	79
Table 28: First-Year Energy Impacts Per Prototype Building – Leak Monitoring.....	79
Table 29: First-Year Energy Impacts Per Prototype Building – Leak Testing.....	80
Table 30: First-Year Energy Impacts Per Compressor Horsepower – Pipe Sizing.....	80
Table 31: First-Year Energy Impacts Per Compressor Horsepower – Leak Monitoring	80
Table 32: First-Year Energy Impacts Per Compressor Horsepower – Leak Testing	81
Table 33: 2023 PV TDV Energy Cost Savings Over 15-Year Period of Analysis – Pipe Sizing	83
Table 34: 2023 PV TDV Energy Cost Savings Over 15-Year Period of Analysis – Leak Monitoring	83
Table 35: 2023 PV TDV Energy Cost Savings Over 15-Year Period of Analysis – Leak Testing	83
Table 36: Pipe Sizing Incremental Costs.....	85
Table 37: Monitoring System Costs.....	85
Table 38: Leak Testing Costs.....	86
Table 39: Labor Rates.....	86
Table 40: 15-Year Cost-Effectiveness Summary Per Prototype – Pipe Sizing.....	88
Table 41: 15-Year Cost-Effectiveness Summary Per Prototype – Leak Monitoring	88
Table 42: 15-Year Cost-Effectiveness Summary Per Prototype – Leak Testing	89

Table 43: Statewide Energy and Energy Cost Impacts – Pipe Sizing	90
Table 44: Statewide Energy and Energy Cost Impacts – Leak Monitoring.....	91
Table 45: Statewide Energy and Energy Cost Impacts – Leak Testing.....	91
Table 46: First-Year Statewide GHG Emissions Impacts	92
Table 47: First-Year Statewide Impacts on Material Use	93
Table 48: Manufacturing Compressed Air Market Size	106
Table 49: Estimated Statewide Market Size by Prototype.....	107
Table 50: Nominal TDV Energy Cost Savings Over 15-Year Period of Analysis – Pipe Sizing	108
Table 51: Nominal TDV Energy Cost Savings Over 15-Year Period of Analysis – Leak Monitoring	108
Table 52: Nominal TDV Energy Cost Savings Over 15-Year Period of Analysis – Leak Testing	108
Table 53: Roles of Market Actors in the Proposed Compliance Process	113
Table 54: Partial List of Contributing Stakeholders	118

List of Figures

Figure 1: Example monitoring points (only first two would be required)	19
Figure 2: Simplified compressed air system.....	21
Figure 3: Compressed air system marketplace.....	35
Figure 4: Prototype weekday load profiles.	63
Figure 5: Prototype weekend load profiles.	64
Figure 6: Energy and demand savings dependence on leak load reduction.	65
Figure 7: Piping layout of Prototype 1 showing path of greatest frictional pressure loss.	67
Figure 8: Piping layouts, not to scale.....	68
Figure 9: Energy and demand savings dependence on piping pressure loss.	78
Figure 10: Aluminum piping costs per foot (black dashed line is average of identified costs).....	84
Figure 11: Piping installation costs.....	85

Executive Summary

This document presents recommended code changes that the California Energy Commission will be considering for adoption in 2021. If you have comments or suggestions prior to the adoption, please email info@title24stakeholders.com. Comments will not be released for public review or will be anonymized if shared.

Introduction

The Codes and Standards Enhancement (CASE) Initiative presents recommendations to support the California Energy Commission's (Energy Commission) efforts to update the California Energy Code (Title 24, Part 6) to include new requirements or to upgrade existing requirements for various technologies. Three California Investor Owned Utilities (IOUs) – Pacific Gas and Electric Company, San Diego Gas and Electric, and Southern California Edison– and two Publicly Owned Utilities – Los Angeles Department of Water and Power and Sacramento Municipal Utility District - (herein referred to as the Statewide CASE Team when including the CASE Author) sponsored this effort. The program goal is to prepare and submit proposals that would result in cost-effective enhancements to improve energy efficiency and energy performance in California buildings. This report and the code change proposals presented herein are a part of the effort to develop technical and cost-effectiveness information for proposed requirements on building energy-efficient design practices and technologies.

The Statewide CASE Team submits code change proposals to the Energy Commission, the state agency that has authority to adopt revisions to Title 24, Part 6. The Energy Commission will evaluate proposals submitted by the Statewide CASE Team and other stakeholders. The Energy Commission may revise or reject proposals. See the Energy Commission's 2022 Title 24 website for information about the rulemaking schedule and how to participate in the process: <https://www.energy.ca.gov/programs-and-topics/programs/building-energy-efficiency-standards/2022-building-energy-efficiency>.

The overall goal of this Final CASE Report is to present a code change proposal for pipe sizing, leak testing, and leak monitoring of compressed air systems. The report contains pertinent information supporting the code change.

Measure Description

Background Information

Compressed air is often called the fourth utility for industrial customers after water, electricity, and natural gas. The associated energy consumption accounts for about 10 percent of all electricity usage in the industrial sector (Xenergy, Inc. 2001, Greenstone, et al. 2019). Based on the market size calculations for this effort, estimated California

compressed air energy consumption is about 9,784 gigawatt hours per year (GWh/yr). Compressed air is used for a wide-ranging spectrum of applications and end uses, from handheld tools to large, custom-built pneumatic machines, to conveyance and transportation in manufacturing processes. This wide range of applications, ubiquity, and distribution of compressed air throughout a facility is why it is often referred to as a utility, despite it not being strictly so.

Despite this widespread, energy-intensive usage, there remain many opportunities for efficiency improvement and increased adoption of best practices. There are several key handbooks and guidelines for compressed air system design and management made available by trade associations, publishers, and compressed air manufacturing firms. Although there is consistency between these various references, adoption of best practices is not assured. Code changes can help encourage proper design, control, and management of this vastly important and largely inefficient fourth utility.

Compressed air typically travels through distribution piping to various end uses in a facility. Demand-side inefficiencies in compressed air systems include inappropriate end uses and artificial demand. Inappropriate end uses include poor utilization of compressed air such as open pipe blowing to clean surfaces. Artificial demand is excess air and energy use due to elevated system pressures. One source of artificial demand is excessive pressure loss in a system between the source and end use resulting from undersized piping. Undersized piping causes excessive frictional pressure losses from rapidly moving air. Operators are then forced to increase the pressure setpoint at the source so that the pressure at the end use is sufficient. Just one undersized pipe to a critical end use can result in excessive pressure setpoints, even if the rest of the distribution system is properly sized.

Compressed Air Challenge guidelines suggest that compressed air systems should be designed to have less than 10 percent pressure loss between the compressor discharge and end use. This includes about five percent loss in the compressor room from dryers and filters and five percent for the frictional piping losses (Marshall 2013). This can be achieved by either comprehensively designing a system using pressure loss calculations or by limiting the air velocity to 20 feet per second (ft/s) in compressor room piping and 30 ft/s in distribution and service line piping. Properly sized piping can help avoid artificial loads which add about 1 percent energy consumption for every two pounds per square inch (psi) increase in discharge pressure needed to overcome this frictional pressure loss.

Due to the physical nature of high-pressure air, piping and tubing fittings, harsh environments, vibration, and long useful life of compressed air systems, leaks are a ubiquitous challenge. A reasonable target for leaks in an industrial setting is about 5-10 percent of total system flow. However, leaks typically account for about 20-30 percent of load in most compressed air systems without proactive leak management programs

(U.S. Department of Energy 2016). Extrapolating from the total California compressed air energy estimate, roughly 2,000-3,000 GWh are wasted each year on leaks statewide.

Leak identification and repair should be an ongoing or periodic maintenance task. Two of the barriers to adoption and implementation of leak management programs are lack of leak load visibility and quantifiable financial benefit from repairs. The literal and figurative invisibility of leaks gets lost in the operation of a busy, noisy industrial facility and is often not easily separable from total compressed air load profile data. Additionally, labor to repair leaks is not trivial, especially if a streamlined management practice has not been established, becoming more daunting over time as leaks mount. As leaks accumulate, they can simply become an accepted operating expense without due consideration. Then practices such as replacing failed drains with partially-open ball valves can become an accepted yet wasteful practice.

Recent developments and trends in the compressed air market include the availability of cost-effective monitoring equipment that can track load, system efficiency, and energy consumption. A non-mandatory standard in Canada was recently developed by the Canada Standards Association (CSA C837-16) that recommends specific monitoring system design and specifications for compressed air systems. Monitoring systems can address barriers to adoption and justification of leak management programs by quantifying and displaying leak loads and energy effects. Valves throughout the piping system can be used for zoning to facilitate leak detection in conjunction with the monitoring data.

Furthermore, tracking of total system efficiency can help flag changes to system efficiency or out-of-expectation energy consumption that would warrant corrective action. A monitoring system enables facility operators to clearly quantify and view the energy and cost returns of such efforts. Indeed, the existing Title 24, Part 6 control requirements for compressed air systems can easily operate sub-optimally; a monitoring system would clearly identify this, enhancing persistence and effectiveness of existing requirements as well as providing a source of new savings. Specific efficiency is a primary key performance indicator (KPI) in most monitoring systems and is important for both ensuring total system efficiency and also in quantifying leaks, especially in systems that include centrifugal compressors that may have excess blow-off.

In addition to the ongoing management of leaks over the life of a compressed air system, new piping installations should be leak and pressure tested before system start-up. Leaks present in distribution piping at installation may be particularly difficult to address once operational due to piping inaccessibility and production schedules. Stakeholders have suggested that new systems should have total leak loads of well below 2 percent if properly tested and sealed before startup. Although many installing contractors perform appropriate leak testing on installation, not all do. The Statewide

CASE Team plans to address this issue by targeting these market actors not following best practices. Furthermore, initializing a system at minimal leak fractions would also help establish a baseline for subsequent monitoring of leak loads over time.

The Statewide CASE Team developed a Title 24, Part 6 proposal for supply-side measures which were adopted in 2013. Soon after, a paper was written on recommended expansions to California's Title 24, Part 6 building codes as it relates to industrial measures (McHugh 2013). Included in these industrial recommendations were compressed air piping leak testing, pipe sizing, air dryer efficiency, and capacity control requirements for centrifugal compressors. All but the compressed air dryer efficiency requirements are being addressed in this proposal. Industry surveys, best practice and design handbooks, and a Canada monitoring standard have been developed over the years, but those were not strictly targeting California or energy codes.

Proposed Code Change

The proposed code change to Title 24, Part 6 includes new mandatory requirements in Covered Processes Section 120.6(e) – Mandatory Requirements for Compressed Air Systems. The new language includes requirements for pipe sizing in the design phase, monitoring systems of air compressor power and system loads, and leak testing of new piping installations. The proposed measures would cover any building types with the covered process but would primarily impact industrial and manufacturing facilities.

The monitoring measure would impact new construction (NC) and additions/alterations (AA) for compressed air systems over 100 hp. This is the same size threshold which requires a load sequencer in the existing code. In some cases monitoring and sequencing can be accomplished by the same equipment. Leak testing and piping sizing measures would impact new piping system installation or replacements greater than 50 adjoining linear feet.

Scope of Code Change Proposal

Table 1 summarizes the scope of the proposed changes and which sections of Standards, Reference Appendices, Alternative Calculation Method (ACM) Reference Manual, and compliance documents would be modified with the proposed changes.

Table 1: Scope of Code Change Proposal

Measure Name	Type of Requirement	Modified Sections of Title 24, Part 6	Modified Title 24, Part 6 Appendices	Would Compliance Software Be Modified	Modified Compliance Documents
Pipe Sizing	Mandatory (NC)	Section 120.6(e)	N/A	No	NRCI-PRC-01-E
Leak Monitoring	Mandatory (NC and AA)	Section 120.6(e)	NA7.13	No	NRCI-PRC-01-E NRCA-PRC-01-F
Leak Testing	Mandatory (NC and AA)	Section 120.6(e)	N/A	No	NRCA-PRC-01-F

Market Analysis and Regulatory Assessment

The compressed air market comprises compressor manufacturers, auxiliary equipment manufacturers, distributors, contractors, engineering firms, consultants, trade associations, and end users. These entities engage with one another to ensure that facilities have custom, reliable compressed air systems for their needs. Best practices and training are largely developed and provided by trade associations, consultants, and manufacturers. In general, there are no technical barriers to facilitating the proposed code changes in any given application as they are based on best practices and widely available technology.

Pipe sizing and design guidelines are consistent across various references. Pressure drop targets and methods for achieving those targets are well-understood and there are specific guidelines to that end. Design reference tables are freely available that can be used to size the diameter and length of pipe based on parameters such as system pressure, loads, velocity, and target pressure loss. However, stakeholders have explained that any given design firm may have its own tools and practices that may or may not adhere to these best practices. Stakeholders have explained that plans documents are routinely, although not universally, drafted for most new construction industrial installations. End users and facility operators are also free to design and install their piping systems themselves. In any case, installers may opt for smaller piping than specified as a cost-cutting measure during the construction process, potentially undercutting design measures.

Monitoring of compressed air systems is a growing trend in the marketplace, especially with proactive, larger facilities. Monitoring systems are available for nearly any potential situation, through a variety of communication protocols, cloud-based data storage and interface, onboard hardware, and a wide range of metering options.

Leak testing of new piping is a best practice, performed using leak detection fluid, observing the pressure decay in a system, observing compressor loading during non-production, ultrasonic leak detection, or by directly measuring leakage with a flow meter.

According to stakeholders, leak testing is performed in most new piping installations but is not necessarily ubiquitous.

The proposed measures would impact various stakeholders in the compressed air market. Builders (system installers) would have to adhere to pipe sizing plan documents, metering installations, and potentially act as test technicians for leakage testing. Building designers would need to adhere to pipe sizing best practices if they do not already and provide plans that demonstrate such practices for a compliance design review. Building owners and occupants would be impacted primarily by first costs, especially for monitoring system components. Building inspectors and plans examiners would have to perform new pipe design plans reviews, confirm installed pipe sizes, and confirm that new piping holds pressure without leaking. Field technicians would have to verify that installed metering is functional and in accordance with the proposed requirements.

Although there is some overlap with existing California plumbing standards, they do not generally impact compressed air except in healthcare buildings. There are no conflicts with any other state or federal codes. Industry standards and best practice guidelines such as the Compressed Air and Gas Institute's (CAGI) Compressed Air and Gas Handbook were used to develop this proposal.

Cost Effectiveness

The proposed code change was found to be cost effective for all climate zones where it is proposed to be required. The benefit-to-cost (B/C) ratio compares the benefits or cost savings to the costs over the 15-year period of analysis. Proposed code changes that have a B/C ratio of 1.0 or greater are cost effective. The larger the B/C ratio, the faster the measure pays for itself from energy cost savings. Based on four modeled prototypes, the B/C ratio is between 1.95 and 9.97 for the pipe sizing submeasure, 2.31 and 9.11 for the monitoring submeasure, and 4.82 and 28.10 for the leak testing submeasure

The measures are not dependent on climate zone. See Section 5 for the methodology, assumptions, and results of the cost-effectiveness analysis.

Statewide Energy Impacts: Energy, Water, and Greenhouse Gas (GHG) Emissions Impacts

Table 2 presents the estimated energy and demand impacts of the proposed code change that would be realized during the first 12 months that the 2022 Title 24, Part 6 requirements are in effect. First-year statewide energy impacts are represented by the following metrics: electricity savings in gigawatt-hours per year (GWh/yr), peak electrical demand reduction in megawatts (MW), natural gas savings in million therms per year

(MMTherms/yr), and time dependent valuation (TDV) energy savings in kilo British thermal units per year (TDV kBtu/yr). See Section 6 for more details on the first-year statewide impacts calculated by the Statewide CASE Team. Section 4 contains details on the per-unit energy savings calculated by the Statewide CASE Team.

Table 2: First-Year Statewide Energy and Impacts

Measure	Electricity Savings (GWh/yr)	Peak Electrical Demand Reduction (MW)	Natural Gas Savings (MMTherms/yr)	TDV Energy Savings (TDV kBtu/yr)
Pipe Sizing	13.6	1.25	N/A	382,330,076
Leak Monitoring	29.3	3.11	N/A	815,197,072
Leak Testing	1.4	0.19	N/A	39,444,846

The energy analysis utilized four prototype systems first developed in the 2013 code cycle for the introduction of compressed air into Title 24, Part 6. Pipe sizing savings were calculated by comparing properly sized piping to one incrementally smaller pipe size. This approach provides a conservative estimate since piping can easily be undersized by multiple standard size increments, thereby wasting more energy than the assumed conditions.

For each site, the leak testing and monitoring analysis assumed that leaks would be reduced from an average of 20 percent (low end of typical leak load assumption) to 10 percent (high end of target range). Of this 10 percent total leak rate reduction, two percent was attributed to leak testing of hard piping at installation and eight percent to ongoing monitoring. A discounted realization rate of 80 percent on monitored leaks was applied to account for imperfect facility behavioral response to leak monitoring alerts and information. Downstream programs implemented throughout California can help ensure that these savings are realized and persist. The required monitoring would have significant symbiosis with programs such as the third-party Industrial Compressed Air Systems Efficiency Program (ICASE) and facility-driven continuous improvement.

Leak monitoring instrumentation can easily be leveraged to include specific efficiency, the benefits are multiplied and complement existing code, providing additional energy benefits not included in this proposal. By providing an efficiency metric, facilities can better ensure that their systems are operating as intended, thereby increasing the realization rate of the existing code. Additional savings associated with responses to specific efficiency monitoring were not included, although they would certainly be present and were already accounted for in the 2013 code cycle to a large extent.

Statewide extrapolation was based on construction forecasts and a market survey that estimated market opportunity, best practice adoption rates, and sizes of installed systems throughout manufacturing facilities.

Table 3 presents the estimated avoided GHG emissions associated with the proposed code change for the first year the standards are in effect. Avoided GHG emissions are measured in metric tons of carbon dioxide equivalent (metric tons CO_{2e}). Assumptions used in developing the GHG savings are provided in Section a and Appendix C of this report. The monetary value of avoided GHG emissions is included in TDV cost factors and is thus included in the cost-effectiveness analysis.

Table 3: First-Year Statewide GHG Emissions Impacts

Measure	Avoided GHG Emissions (Metric Tons CO_{2e}/yr)	Monetary Value of Avoided GHG Emissions (\$2023/yr)
Pipe Sizing	3,275	\$98,251
Leak Monitoring	7,049	\$211,467
Leak Testing	339	\$10,180
Total	10,663	\$319,898

Water and Water Quality Impacts

The proposed measure is not expected to have any impacts on water use or water quality, excluding impacts that occur at power plants.

Compliance and Enforcement

Overview of Compliance Process

The Statewide CASE is continuing to discuss compliance pathways with stakeholders to develop the best process that would also minimize burden on all involved market actors. During rulemaking, the compliance process can be refined accordingly.

The compliance process is described in Section 2.5. Impacts that the proposed measure would have on market actors is described in Section 3.3 and Appendix E. The key issues related to compliance and enforcement are summarized below:

- Pipe sizing requirements would necessitate consistent development of piping plan documents which list pipe diameters and pressure drop calculations or peak loads in cubic feet per minute (cfm). A new plans review would be required. Installation shall adhere to approved plans and be verified in form NRCI-PRC-01-E.
- Monitoring equipment would be specified by designers for new systems or other market actors when compressors are replaced or added and the capacity threshold is triggered. The functionality of installed monitoring would be confirmed by the installer.

- Leak testing compliance would likely be performed by the building inspector by observing system pressure in a no-load state and confirming that pressure is maintained for 30 minutes. This is modeled on current gas pipe leak testing in the California Plumbing Code.

Field Verification and Acceptance Testing

A plans review and permit would be necessary for the proposed pipe sizing measure. A field verification of pipe sizing is not expected, but additional discussion with compliance market actors is needed to settle on a final recommendation. Some jurisdictions may opt for field verification as is already done in some cases. Plans may not always be available in smaller installations and pipe sizes could potentially be confirmed after installation by building inspectors.

Monitoring equipment would be verified via an installing technician acceptance test that includes confirmation of visual display of the required key performance indicators and a functional checklist. Inclusion of monitored points may also be required in the plans review associated primarily with the pipe sizing measure but is likely not necessary.

Leak testing compliance would require verification by building inspectors. The test would be a pressure test, modeled after currently codified pressure testing for natural gas piping. This is in lieu of an acceptance test of actual leak loads to avoid additional acceptance testing burden and addition of new testing methods to the code. The test must be completed on any triggered system and verified in the permitting documentation.

Section 2.5 provides additional details regarding the verification and acceptance testing of the proposed measures.

1. Introduction

This document presents recommended code changes that the California Energy Commission will be considering for adoption in 2021. If you have comments or suggestions prior to the adoption, please email info@title24stakeholders.com. Comments will not be released for public review or will be anonymized if shared.

The Codes and Standards Enhancement (CASE) initiative presents recommendations to support the California Energy Commission's (Energy Commission) efforts to update California Energy Code (Title 24, Part 6) to include new requirements or to upgrade existing requirements for various technologies. Three California Investor Owned Utilities (IOUs) – Pacific Gas and Electric Company, San Diego Gas and Electric, and Southern California Edison– and two Publicly Owned Utilities – Los Angeles Department of Water and Power and Sacramento Municipal Utility District - (herein referred to as the Statewide CASE Team when including the CASE Author) sponsored this effort. The program goal is to prepare and submit proposals that would result in cost-effective enhancements to improve energy efficiency and energy performance in California buildings. This report and the code change proposal presented herein are a part of the effort to develop technical and cost-effectiveness information for proposed requirements on building energy-efficient design practices and technologies.

The Statewide CASE Team submits code change proposals to the Energy Commission, the state agency that has authority to adopt revisions to Title 24, Part 6. The Energy Commission will evaluate proposals submitted by the Statewide CASE Team and other stakeholders. The Energy Commission may revise or reject proposals. See the Energy Commission's 2022 Title 24 website for information about the rulemaking schedule and how to participate in the process: <https://www.energy.ca.gov/programs-and-topics/programs/building-energy-efficiency-standards/2022-building-energy-efficiency>.

The overall goal of this Final CASE Report is to present a code change proposal for pipe sizing, monitoring, and leak testing of compressed air systems. The report contains pertinent information supporting the code change.

When developing the code change proposal and associated technical information presented in this report, the Statewide CASE Team worked with a number of industry stakeholders including building officials, compressed air system manufacturers, compressed air service providers, energy consultants, utility incentive program managers, Title 24, Part 6 energy analysts, and others involved in the code compliance process. The proposal incorporates feedback received during a public stakeholder workshop that the Statewide CASE Team held on November 7, 2019 (Statewide CASE Team 2019), outreach efforts through both phone and email conversations, and a public comment period.

The following is a brief summary of the contents of this report:

- Section 2 – Measure Description of this Final CASE Report provides a description of the measure and its background. This section also presents a detailed description of how this code change is accomplished in the various sections and documents that make up the Title 24, Part 6 Standards.
- Section 3 – In addition to the Market Analysis section, this section includes a review of the current market structure. Section 3.2 describes the feasibility issues associated with the code change, including whether the proposed measure overlaps or conflicts with other portions of the building standards, such as fire, seismic, and other safety standards, and whether technical, compliance, or enforceability challenges exist.
- Section 4 – Energy Savings presents the per-unit energy, demand reduction, and energy cost savings associated with the proposed code change. This section also describes the methodology that the Statewide CASE Team used to estimate per-unit energy, demand reduction, and energy cost savings.
- Section 5 – Cost and Cost Effectiveness includes a discussion and presents the lifecycle cost and cost-effectiveness analysis
- Section 6 – First-Year Statewide Impacts presents the statewide energy savings and environmental impacts of the proposed code change for the first year after the 2022 code takes effect. This includes the amount of energy that would be saved by California building owners and tenants and impacts (increases or reductions) on material with emphasis placed on any materials that are considered toxic by the state of California. Statewide water consumption impacts are also reported in this section.
- Section 7 – Proposed Revisions to Code Language concludes the report with specific recommendations with ~~strikeout~~ (deletions) and underlined (additions) language for the Standards, Reference Appendices, Alternative Calculation Method (ACM) Reference Manual, Compliance Manual, and compliance documents.
- Section 8 – Bibliography presents the resources that the Statewide CASE Team used when developing this report.
- Appendix A: Statewide Savings Methodology presents the methodology and assumptions used to calculate statewide energy impacts.
- Appendix B: Nominal Cost Savings presents the methodology and assumptions used to calculate the electricity embedded in water use (e.g., electricity used to draw, move, or treat water) and the energy savings resulting from reduced water use.
- Appendix C: Environmental Impacts Methodology presents the methodologies

and assumptions used to calculate impacts on GHG emissions and water use and quality.

- Appendix D: California Building Energy Code Compliance (CBECC) Software Specification presents relevant proposed changes to the compliance software (if any).
- Appendix E: Impacts of Compliance Process on Market Actors presents how the recommended compliance process could impact identified market actors.
- Appendix F: Summary of Stakeholder Engagement documents the efforts made to engage and collaborate with market actors and experts.

2. Measure Description

2.1 Measure Overview

This report proposes a series of changes to the compressed air system requirements in Title 24, Part 6 based on energy calculations, measure costs, market characteristics, and stakeholder input. Although the supply side of compressed air systems have been covered since the 2013 Title 24, Part 6 code cycle, the proposal expands coverage to include demand side measures. The proposed changes are mandatory and would impact any facility that has permanent compressed air system triggered by the requirements. Most of the covered situations would be in industrial and manufacturing buildings.

The proposal includes several standalone changes, each of which have their own associated savings, justification, and compliance pathways:

- Pipe sizing of compressed air distribution systems
- Monitoring for leak and efficiency maintenance
- Leak testing of compressed air piping
- Clean-up of existing language

Pipe Sizing of Compressed Air Distribution Systems

The pipe sizing measure would require selection of pipe diameters in line with recommended best practices to mitigate frictional pressure losses in the distribution network. This requirement would apply to any new construction piping installation or added piping over 50 adjoining feet in length. The measure would reduce unnecessarily high compressor discharge pressures. Compressor discharge pressures are often elevated to overcome excessive distribution piping pressure drops, which can be avoided through proper pipe sizing specifications. Compliance would be achieved through a plans design review and potentially a visual inspection after installation to confirm that diameters are equal to plan specifications.

Monitoring for Leak and Efficiency Maintenance

The monitoring measure would require the installation of meters which would facilitate continuous monitoring of energy, load, and efficiency of any new compressed air system with capacities greater than or equal to 100 horsepower (hp).

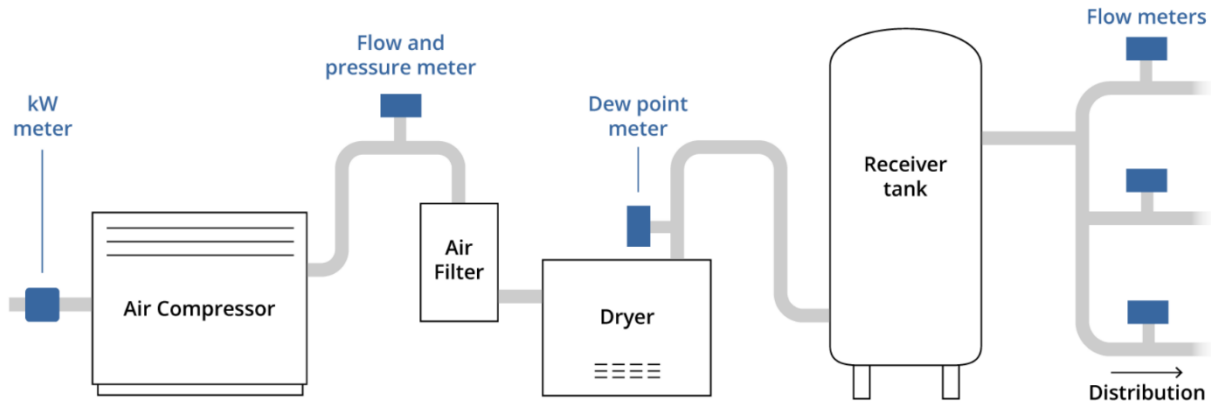

Figure 1: Example monitoring points

Additions or replacements of compressors to existing systems would also trigger this requirement if the 100 hp threshold is met. The measure would require that system pressure and airflow be monitored as well as power of each individual compressor. The monitoring system shall include power (kW), pressure (psig), load (cfm), and specific efficiency (kW/100 cfm), at a minimum. This would ensure that load growth due to leaks is identified, providing direct economic feedback when leakage rates are excessive and necessitate detection and repair. This type of monitoring can directly address the primary barriers to proper compressed air system management and energy efficiency maintenance. When combined with isolation valves, one could potentially use this monitoring system to identify which portions of the compressed air system is leaking. Even if existing code requirements are satisfied, specific efficiency monitoring could help flag issues – those caused by control system parameters or otherwise – that can cause a system to operate inefficiently. Compliance certification would be achieved by an acceptance test conducted by the installing technician of installed meters and monitoring output.

Leak Testing of Compressed Air Piping

The leak testing requirement applies to new construction of compressed air systems and to additions and alterations of over 50 adjoining feet in length. Any adjoining lengths greater than 50 feet would be tested for leaks according to a pressure test and any shorter lengths can be tested using a leak-detection fluid. Both of these methods are already codified for natural gas systems in the California Plumbing Code. This would ensure that leaks are not present at installation, codify best practices, and mitigate leaks in inaccessible header and distribution piping before plants or new end uses are operational. Compliance would be confirmed by the submission of an installation certificate by the installing contractor and confirmed by pressure gauge observation by the building inspector, similar to current natural gas piping verification.

Clean-up of Existing Language

Several clean-up measures that do not impact stringency are recommended. Removal of the term “online” from the existing language is necessary to streamline compliance, reduce confusion, and facilitate downstream programs. The use of “online” to designate which compressors are back-up is not an industry standard term, nor is it evident in any given plant whether a compressor should be considered “online.” This change would help mitigate confusion generated by the existing language as reported by stakeholders.

The existing language exempts alterations to any system that has a centrifugal compressor for all existing requirements. Although the 2013 CASE Report found that the existing measures were cost-effective for systems with centrifugal compressors, this exception was inserted during rulemaking in response to stakeholder feedback regarding limited compliance options and feasibility concerns. Advanced controls for centrifugal compressors were less feasible at the time. However, controls have advanced since then and products for the various situations that include centrifugal compressors are readily available. The proposed clean-up suggests removing the exception to the existing controls requirement which was originally found to be cost-effective for the centrifugal system prototype in the 2013 CASE Report. Additionally, the exception must be moved to ensure that the proposed new requirements apply to systems with centrifugal compressors.

Beyond these two clean-up changes, there are other, small changes to help simplify and clarify the language without any effect on intent or coverage.

None of the proposed changes require any modification to compliance software. Compliance software does not currently include compressed air, and the Statewide CASE Team does not recommend that it should.

2.2 Measure History

Compressed air systems were first introduced into Title 24, Part 6 in 2013 (California Utilities Statewide Codes and Standards Team 2013). The Final CASE Report for the 2013 code cycle focused on supply-side measures which were ultimately adopted by the California Energy Commission. These measures included controls, trim capacity, and storage and have remained in place and unchanged since 2013. Although leaks were identified as a large opportunity in the 2013 Final CASE Report, leak measures were not pursued, attributed to the fact that new construction systems have minimal leakage. Leak testing and performance monitoring were scoped by the Statewide CASE Team but were ultimately not pursued, particularly because it was the first time many of the users and manufacturers would be required to take in consideration and comply with Title 24 requirements. Therefore, it was very important to emphasize simplicity. As a

result, the 2013 proposal focused on two broadly applicable supply-side measures (variable speed compressors and smart controls).

Soon after adoption of the 2013 California Energy Code, members of the Statewide CASE Team recommended pursuing additional industrial efficiency measures including demand side compressed air efficiency measures in future code cycles (McHugh 2013). During the development of this report there were multiple stakeholders that contended that demand-side measures were the best unaddressed energy opportunity in the compressed air industry. There are no existing California code measures or standards regarding pipe sizing, leakage testing, and system monitoring. This proposal is based on best practice guidelines, such as the Compressed Air and Gas Institute's (CAGI) Compressed Air and Gas Handbook, and stakeholder recommendations.

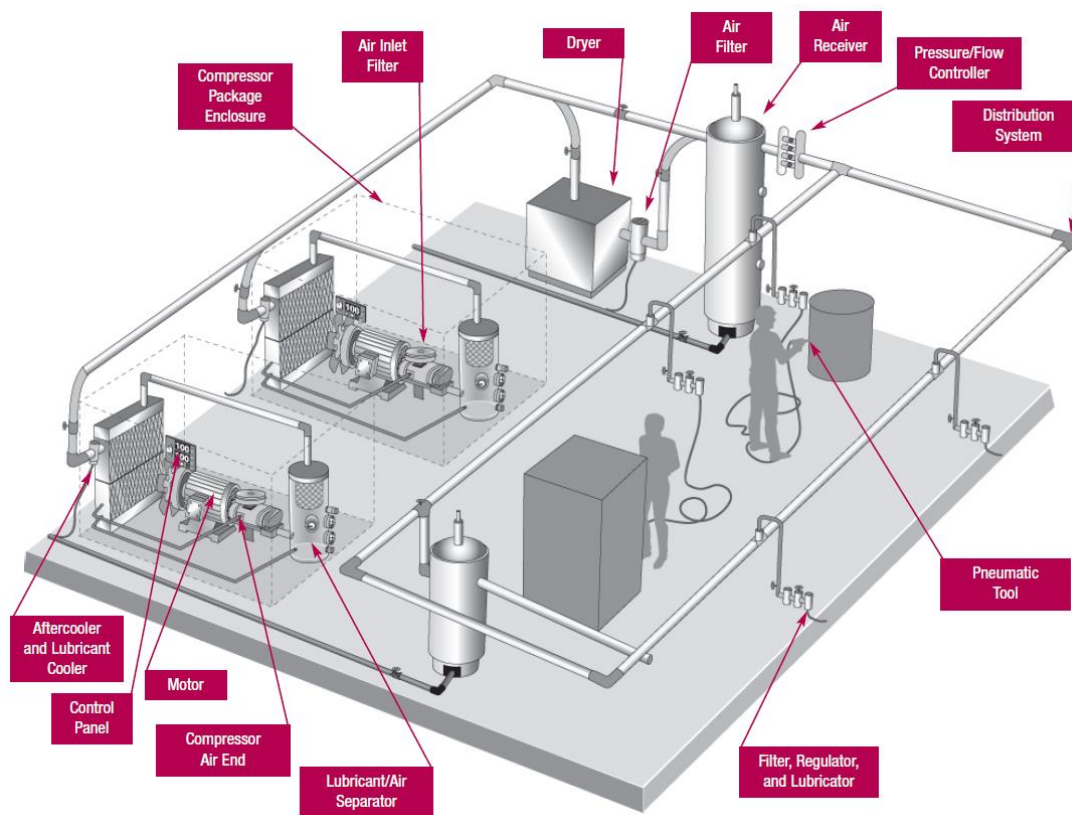

Figure 2: Simplified compressed air system.

Source: (U.S. Department of Energy 2016)

Distribution piping designs are unique for any given site, but all designs share a common principle regarding energy efficiency: undersized piping can result in overly constricted flow and frictional losses between the compressor and end uses. If pipes are undersized, compressor pressure setpoints must be increased to overcome frictional losses to deliver air at the required pressure throughout the system. This is often one of

the primary sources of artificial demand in a system and can be mitigated through proper pipe sizing.

Leak management in compressed air systems is not a new recommendation. The topic of leak management is covered throughout literature with supporting arguments, case studies, and best practice recommendations for as long as there has been compressed air. Despite this near-continuous advocacy, leak management best practices have never become ubiquitous and still are only utilized by a minority of end users (Xenergy, Inc. 2001). Based on discussions with stakeholders and literature, it is widely understood that leaks typically account for 20-30 percent of loads in most compressed air systems that do not have proactive leak management programs while 5-10 percent is the typical cost-effective target (U.S. Department of Energy 2004, CEA Technologies 2007, Marshall 2018).

Barriers to the market penetration of proper leak management include lack of visibility on total leak load and load growth, lack of visibility on financial incentive and cost effectiveness of fixing leaks, lack of perception of production effects of leaks, and other barriers typical to continuous improvement practices. As stated in one article:

“until recently, compressed air system maintenance was reactive... the facility is in the dark about maintenance needs, suffers from inefficiencies, and is at increased risk of breakdown... Understanding the entire compressed air system’s dynamics is the first step toward efficiency energy usage and energy savings. Remote monitoring of compressed air data will provide transparency into a compressed air network from the supply side through distribution. Logging critical parameters from the network is the only valid approach to show the current energy performance of the installation. These parameters include but are not limited to power, flow, and pressure,” (Blum 2015).

As CAGI’s 10 Steps to Savings states, “the first step to reduce compressed air energy costs is to measure and monitor your compressed air system’s energy consumption, flow rates and operating air pressure,” (Compressed Air & Gas Institute n.d.).

Monitoring of compressed air systems has begun to gain market traction, especially with larger, more efficiency-focused facility operators. Reduced sensor costs, improved capabilities, communication protocols, cloud data services, and data algorithms have all contributed to a relatively new, broadly applicable category of compressed air monitoring products. Case studies of monitoring technologies implemented at various facilities have demonstrated their benefits to leak load management and system efficiency improvements. The Statewide CASE Team spoke with many stakeholders who described monitoring of compressed air systems as the biggest forthcoming shift in the industry and one which would have wide-ranging energy benefits.

In addition to helping track, justify, and measure the benefits of leak management efforts, monitoring systems can easily include compressed air system specific power which is measured in kW/100 cfm for a given system pressure. A well-functioning system operating at 100 psig typically has a specific power of 20 kW/100 cfm or lower.

Specific efficiency tracking can easily flag effects of changes in the system controls, components, distribution system, or end uses. These effects are often otherwise unobservable, obfuscating unnecessary energy use increases uncoupled to production output. Stakeholders have explained that expected gains from code-required master controllers are often subverted by mechanical or programming issues (such as changes to control parameters). These failures can easily cause the system to operate inefficiently, even more so than if the currently required master controllers were not installed. Tracking system efficiency can ensure systems are operating as intended by alerting operators when faults or mistakes necessitate corrective action.

New piping lengths and distribution systems are typically installed by piping contractors, compressed air firms, or facility operators. Best practice in any case is to ensure tight fittings and mitigation of leaks prior to start-up. This can be done by testing for leaks in any new lengths of pipe by either pressurizing the system and observing compressor operation and pressure loss or by using a leak detection fluid at joints and fittings. Since this is best practice and can identify leaks in piping headers and branches that may be difficult to address once a plant is operational, requiring such a test can ensure that leaks are not present at system start-up, especially in hard-to-reach locations.

2.3 Summary of Proposed Changes to Code Documents

The sections below summarize how the standards, Reference Appendices, Alternative Calculation Method (ACM) Reference Manual, and compliance documents would be modified by the proposed change. See Section 7 of this report for detailed proposed revisions to code language.

2.3.1 Summary of Changes to the Standards

This proposal would modify the following sections of the California Energy Code as shown below. See Section 7.2 of this report for marked-up code language.

Section 120.6(e) – Mandatory Requirements for Compressed Air Systems: Three new subsections are proposed, 120.6(e)3-5, each of which is an individual code requirement: pipe sizing, monitoring, and leak testing of compressed air piping. The importance and purpose of each of these changes for each subsection is discussed below.

Section 120.6(e): strike the word “online” from the language. The purpose of this change is to help avoid confusion in compliance and coverage ambiguity that has been reported by stakeholders. This is necessary because “online” is not an industry-standard term or easily definable for any given situation. To ensure that stringency is not increased by striking this term, the existing language for controls is modified to cover systems with “three or more compressors” thereby excluding coverage of systems

with a redundant or backup compressor, as was the original intent of using the term “online.”

Exception 1 to Section 120.6(e): This existing exception for 120.6(e) exempts any alterations of existing compressed air systems with centrifugal compressors. This exception was moved from the overall section 120.6(e) to the existing subsection 120.6(e)1. The purpose of this is ensure that existing control requirements and the new proposed requirements apply to systems with centrifugal compressors. This is necessary since only the trim requirement would have particularly prohibitive barriers with existing centrifugal compressors and the other requirements are applicable and feasible regardless of compressor type.

Exception 2 to Section 120.6(e): This existing exception to 120.6(e) addresses how requirements for compressed air systems apply in healthcare facilities. The language was modified so the compressed air requirements apply to healthcare except for medical gas compressed air systems. The purpose of this is to ensure coverage of process compressed air that does not have life-support and medically-critical loads. This change is necessary since healthcare facilities can sometimes have non-medical gas compressed air systems that should be covered.

Section 120.6(e)1 – Trim Compressor and Storage: The measure language is unchanged, but exceptions are modified. The purpose of the changes to exceptions was to mitigate any effects of removing the term “online.” This is important since the removal of the term “online” could increase stringency of the existing trim compressor requirement without mitigating language. Additionally, an exception for alterations that include new variable speed compressors and sufficient storage was included since that type of compressor will inherently provide additional trim capacity.

Section 120.6(e)2 – Controls: The existing language is modified to enhance clarity and avoid confusion with control system requirements. In particular, it is modified to ensure that controls can operate in response to demand as determined by any industry-standard method instead of “based on the current air demand as measured by a sensor.” The purpose of this change is to ensure that industry-standard control methods can be used without concern or confusion over code language that previously could be interpreted to mean that controls must respond to direct airflow measurements. This is necessary since stakeholders had expressed concern and confusion over the meaning of the existing language that is in conflict with typical controller capabilities and best practices.

Section 120.6(e)3 – Monitoring: This is a new subsection requiring metering and monitoring of key performance indicators of a compressed air system’s supply and demand. The required monitoring points include system pressure, compressor power or amps, airflow, and system efficiency. The purpose of this monitoring requirement is to provide facility operators insight into their system’s energy consumption, performance,

and demand characteristics. This change is important because compressed air users typically have little-to-no insight into the compressor system performance and do not often have justification or visible reasons to maintain system efficiency. The monitoring requirement would directly address the primary barriers to continuous system improvement and maintenance by providing insight, visibility, accountability, and enabling quantification of cost and energy benefits.

Section 120.6(e)4 – Leak Testing of Compressed Air Piping: This is a new subsection requiring quality installation of new compressed air piping without leaks. The purpose of this new requirement is to ensure piping installers are following industry standard best practices for piping installation and commissioning. This is important because new piping should be absent of leaks that would then be difficult or impossible to address after start-up and could last for the life of the plant. Beyond energy savings, this will benefit facility operations by ensuring long-term system reliability and compressed air availability.

Section 120.6(e)5 – Pipe Sizing: This is a new subsection requiring proper sizing of compressed air piping at design and construction phases, per typical best practice guidelines. The purpose of this is to minimize pressure losses in undersized piping which then require compressors to run at avoidably high pressure setpoints to overcome the artificial losses. This is important because systems can be undersized due to poor adherence to design practices or cost-cutting efforts associated with pipe material and installation costs. Once installed, piping frictional pressure losses will be present for the life of the system and should be avoided upfront with proper pipe sizing practices.

2.3.2 Summary of Changes to the Reference Appendices

This proposal would modify the NA7.13 of the Reference Appendices and add a new monitoring functional test. See Section 7 of this report for the detailed proposed revisions to the text of the reference appendices.

2.3.3 Summary of Changes to the Nonresidential ACM Reference Manual

The proposed code change would not modify the Nonresidential ACM Reference Manual.

2.3.4 Summary of Changes to the Nonresidential Compliance Manual

The proposed code change would modify the following section of the Nonresidential Compliance Manual:

Nonresidential Compliance Manual Section 10.8 – Compressed Air Systems:

Additional sections that provide clarifying examples of covered situations for the new

proposed sections would be included. Additionally, the existing examples would be modified to match the clean-up efforts for existing language, if necessary.

See Section 7.5 of this report for the detailed proposed revisions to the text of the Compliance Manuals.

2.3.5 Summary of Changes to Compliance Documents

The proposed code change would modify some compliance documentation (NRCI-PRC-01-E and NRCA-PRC-01-F) but should not require any new forms. These documents would require certification of pipe leak testing and monitoring acceptance testing.

2.4 Regulatory Context

2.4.1 Existing Requirements in the California Energy Code

Title 24, Part 6, Section 120.6(e) outlines mandatory requirements for compressed air systems. There are no existing requirements in the California Energy Code for pipe sizing, monitoring, or leak testing of compressed air piping. The proposed measures build upon existing requirements by revising existing code language for clarity and ease of compliance, adding these additional requirements.

Title 24, Part 6, Section 120.6(e) requires all compressed air systems greater than 25 hp to meet each subsection, unless the system is subject to an exception. Currently, systems that include one or more centrifugal compressors and any compressed air system serving healthcare facilities, which includes medical gas, are exempt from 120.6(e).

Title 24, Part 6, Section 120.6(e) Subsection 1 outlines requirements for proper selection of a trim compressor and compressed air storage. All covered systems must comply with Subsection 1 through one of two methods.

The first method requires compressed air systems include a compressor with one or more variable speed drives (VSD). Any systems comprised of more than one compressor must have a total combined capacity of VSD compressor(s) that is at least 1.25 times the largest net capacity increment between the various combinations of existing compressors. To determine the largest net increment, it is necessary to write out, in ascending order, the total system capacity between various compressor combinations available in the system. The largest net increment would be the largest nominal difference, in actual cubic feet per minute (cfm), between two identified compressor combinations. Subsection A also requires that primary compressed air storage of at least one gallon per cfm of the largest trim compressor is included in the system.

The second method requires compressed air systems include a compressor or set of compressors with a trim capacity of the largest of the following two options: the size of the largest net capacity increment between various combinations of compressors, or the capacity of the smallest compressor. The total effective trim capacity of single compressor systems need to cover a range between 70 percent and 100 percent of the rated capacity and the specific power of the compressor (kW/100 cfm) should be maintained within 15 percent of the specific power at the most efficient operating point. Subsection B also requires that primary storage of at least two gallons per cfm of the largest trim compressor is included in the system.

Title 24, Part 6, Section 120.6(e) Subsection 1 provides for two exceptions. Exception 1 is for compressed air alterations of less than 50 percent of the online capacity of the system. Exception 2 is for systems that have demonstrated air demand that fluctuates less than 10 percent.

Title 24, Part 6, Section 120.6(e) Subsection 2 provides the controls requirements for compressed air systems with more than one compressor with a total combined hp rating of greater than 100 hp. For systems meeting these requirements, a controller must be included that would select the most efficient combination of compressors within the system based on measured compressed air demand.

Title 24, Part 6, Section 120.6(e) Subsection 3 requires that compressed air acceptance tests NA7.13 be completed and submitted to the enforcement agency.

2.4.2 Relationship to Requirements in Other Parts of the California Building Code

There were no identified conflicting overlaps with requirements in California Mechanical Code (CMC) or California Plumbing Code (CPC). The CPC does outline a method of natural gas leak pressure testing that provided a model for the proposed leak testing measure.

Chapter 12 “Fuel Gas Piping”, Section 1213 “Pressure Testing and Inspection” of the CPC outlines a pressure test for fuel gas piping to ensure absence of leaks for safety assurances. For any failed test, the installer must locate the leaks and repair them prior to subsequent pressure testing. The test language is as follows:

1213.3 Test Pressure. *This inspection shall include an air, CO₂, or nitrogen pressure test, at which time the gas piping shall stand a pressure of not less than 10 psi (69 kPa) gauge pressure. Test pressures shall be held for a length of time satisfactory to the Authority Having Jurisdiction, but in no case less than 15 minutes with no perceptible drop in pressure. For welded piping, and for piping carrying gas at pressures in excess of 14 inches water column pressure (3.5 kPa), the test pressure shall be not less than 60 psi (414 kPa) and shall be continued for a length of time satisfactory to the Authority Having Jurisdiction, but in no case for less than 30 minutes. For CSST carrying gas at*

pressures in excess of 14 inches water column (3.5 kPa) pressure, the test pressure shall be 30 psi (207 kPa) for 30 minutes. These tests shall be made using air, CO₂, or nitrogen pressure and shall be made in the presence of the Authority Having Jurisdiction. Necessary apparatus for conducting tests shall be furnished by the permit holder. Test gauges used in conducting tests shall be in accordance with Section 318.0.

Section 318 covering the requirements for test gauges is as follows:

318.1 General. *Tests in accordance with this code, which are performed utilizing dial gauges, shall be limited to gauges having the following pressure graduations or incrementations.*

318.2 Pressure Tests (10 psi or Less). *Required pressure tests of 10 pounds-force per square inch (psi) (69 kPa) or less shall be performed with gauges of 0.10 psi (0.69 kPa) incrementation or less.*

318.3 Pressure Tests (Greater Than 10 psi to 100 psi). *Required pressure tests exceeding 10 psi (69 kPa) but less than or equal to 100 psi (689 kPa) shall be performed with gauges of 1 psi (7 kPa) incrementation or less.*

318.4 Pressure Tests (Exceeding 100 psi). *Required pressure tests exceeding 100 psi (689 kPa) shall be performed with gauges incremented for 2 percent or less of the required test pressure.*

318.5 Pressure Range. *Test gauges shall have a pressure range not exceeding twice the test pressure applied.*

In addition, Chapter 12 also outlines sizing guidelines for fuel gas piping based on the operating pressure and end use demand. Piping lengths are sized for the summation of any downstream loads using tables that specify carrying capacity in cubic feet of fuel gas per diameter. However, the requirements, code intentions, and operating conditions for fuel gas are divergent from covered process compressed air. Although there are similar governing physical laws, one cannot strictly be a model for the other.

Chapter 13 “Health Care Facilities and Medical Gas and Medical Vacuum Systems” of the CPC outlines some sizing requirements for minimum pressure loss in medical gas piping design. However, medical gas operates at far lower pressures and flow rates, and is primarily concerned with ensuring safe, reliable air supply to medical equipment. Thus, the CPC was used as a reference point for this proposal development, but the conditions and goals of the CPC are divergent enough from those of this proposal development that they should not be modeled after one another.

Section 1319 of the CPC outlines functional tests for end uses, purge valves and a pressurized leak test procedure for new medical gas piping as summarized follows:

Initial pressure test (§1319.5): Pressurize system with nitrogen gas to 1.5 times the operating pressure and not less than 150 pounds per square inch gauge (psig). Each

joint shall be examined for leakage by means of a leak detecting fluid. Any identified leaks must be repaired.

Standing Pressure Tests - For Positive Pressure Medical Gas Piping Systems

(§1318.9) The system is pressurized with nitrogen gas to 1.2 times the operating pressure and left standing in isolation for 24 hours. For medical gas, no change in pressure is allowed except attributable to changes in temperature. For Category 3 systems (non-medical gas for machines), the pressure drop is not allowed to be greater than five psig.

Chapter 14 “Process Piping” of the California Mechanical Code (CMC) also requires pressure testing of process piping. Process piping is defined as *piping or tubing that conveys liquid or gas, which is used directly in research, laboratory, or production processes.*

CMC Section 1405.2.2 Final Piping Inspection. *This inspection shall be made after piping authorized by the permit has been installed and after portions thereof that are to be covered or concealed are so concealed. This inspection shall include a pressure test, at which time the piping shall stand a pressure of not less than one-and-one-half times the maximum designed operating pressure where hydraulic testing is conducted or 110 percent where testing is conducted pneumatically. Test pressures shall be held for a length of time satisfactory to the Authority Having Jurisdiction, but in no case for less than 30 minutes with no perceptible drop in pressure. HPM drain, waste, and vent piping shall be tested in accordance with the plumbing code. Tests shall be made in the presence of the Authority Having Jurisdiction. Necessary apparatus for conducting tests shall be furnished by the permit holder.*

The Statewide CASE Team is not aware of California building standards that specifically regulate the testing of compressed air piping. However, building inspectors and mechanical contractors who install gas piping, medical gas piping, or process piping are aware of standing pressure tests and the use of leak detecting fluids for testing for leaks. This proposal recommends that compressed air piping leak testing be conducted at time of installation of new compressed air piping in a similar manner that fuel gas piping, medical gas piping and process gas piping is tested in the other portions of the California building codes. This proposal is written so compressed air piping testing is included in Title 24, Part 6 but the case could be made that this testing requirement could be included in the California Plumbing Code (Title 24, part 5) or in the California Mechanical Code (Title 24, part 4).

2.4.3 Relationship to Local, State, or Federal Laws

The California Code of Regulations (CCR) includes compressed air in Article 7, which discusses the safe practice of compressed air or gases. Subsection (f) specifically discusses that safe pressure testing of any object must be in accordance with Section 560(c) and (d) of the Unfired Pressure Vessel Safety Orders.

There are no other relevant local, state, or federal laws and none overall that impact or overlap with the proposed language.

2.4.4 Relationship to Industry Standards

CSA C837-16 is a standard for Monitoring and Energy Performance Measurements of Compressed Air Systems (CSA Group 2016). This standard provides open-ended guidelines for assessing compressed air systems, including recommendations for “levels of monitoring” spanning measurement frequency, measurement points, system boundaries, and other factors. The proposed code shares most similarities to Level 3 monitoring in C837-16. Level 3 involves permanently installed metering and instrumentation with an energy management information system used for ongoing and continuous monitoring and management of the compressed air system. This level is appropriate for large compressed air systems of high energy intensity.

CSA C837-16 specifies thresholds based on nominal system capacities and percentage of site energy use to determine which level of measurement would be recommended. These levels are used for guidance and reference in generating similar thresholds for proposed code requirements.

International Organization for Standardization (ISO) 50001 provides a method and standardized process for improving energy use through an energy management system and continuous improvement. ISO 50001 is often used to organize an entity, from whole corporations to individual factories, towards achieving better energy efficiency through ongoing energy management practices. The standard is often applied to industrial facilities and is the preeminent continuous improvement guideline. Data acquisition, monitoring, and energy visibility is typically a key pillar of success for such IOS 50001 certified facilities in their continuous improvement cycles. The monitoring system requirement proposed here has a significant overlap with this widely-utilized standard. Along ISO 50001 practices, it would facilitate the energy saving actions and enable continuous improvement that is otherwise not readily feasible in compressed air systems.

American Society of Mechanical Engineers (ASME) B31.3 provides a standard for hydrostatic and pneumatic testing of metallic process piping. ASME typically provides code standards for guidance on safety and quality assurance, rather than efficiency. Furthermore, these standards relate to piping conveying a broad array of fluids including chemicals, petroleum products, gas, air, steam, water, refrigerants, and others. ASME B31.3 does not provide guidelines for leak testing of compressed air piping, but the proposed measure for leak pressure testing shares similar methodology and was referenced in generating the pneumatic testing procedure.

National Fire Protection Association (NFPA) 55 Compressed Gases and Cryogenic Fluids Code specifies a number of ventilation and spacing requirements for fire safety

consideration. In general, there is not a strong relationship to the NFPA code to the proposed or existing Title 24, Part 6 compressed air code.

NFPA 99 Health Care Facilities Code outlines requirements for compressed air in medical gas systems. This is the basis of the CPC medical gas code described in Section 2.4.2.

American National Standards Institute/International Society of Automation (ANSI/ISA) S7.0.01-1996 provides standards on acceptable compressed air composition to maintain instrument quality. The compression of air increases condensation and introduces contaminants such as oil. This has no relationship to the proposed or existing code as the quality of the compressed air is not regulated in Title 24, Part 6.

2.5 Compliance and Enforcement

When developing this proposal, the Statewide CASE Team considered methods to streamline the compliance and enforcement process and ways to mitigate negative impacts on market actors who are involved in the process. This section describes how to comply with the proposed code change and the compliance verification process. Appendix E presents how the proposed changes could impact various market actors.

The activities that need to occur during each phase of the project are as follows:

- **Design Phase:** The proposed requirements would change design procedures as the designers would have to evaluate and specify the following in their plans for new piping systems:
 - Metering locations and equipment for the required monitoring.
 - Pipe diameters and flow rates at each interconnection, riser, header, branch, and service line or calculated pressures at end use locations.

Based on stakeholder feedback on current design practices, many designers and compressed air firms already size appropriately and the requirements would only appreciably affect those not yet adhering to best practices. Small and medium size piping installations may not always have plans documents; this could prove to be an initial compliance challenge until the market adapts.

- **Permit Phase:** The Certificate of Compliance documents would need to be provided to the plans examiner during the permit application phase. The plans examiner would need to be aware of the code requirements and compliance document changes. The plans examiner would also need to understand how the code requirements should be integrated into the design, while ensuring that all existing codes and standards for compressed air systems are being properly addressed as they would have been regardless of the new measure. The plans examiner would need to confirm metering sections satisfy the new requirements

and that the piping sizes and/or pressure loss to the end uses are within the acceptance threshold.

- **Construction Phase:**

- For the pipe design requirement, installers would need to adhere to plan document specifications. Any alteration to the approved design plan or work order must be reviewed and re-approved by the designer to ensure code compliance. Installers would fill out the NRCI-PRC-01-E Certificate of Installation to certify piping was installed in accordance with design specifications.
- For the metering and monitoring requirement, installers would need to install and commission the required sensors and monitoring system, confirming their functionality and outputs before final inspection. Functionality would be verified with an acceptance test performed by the installing field technician, aligning with the other process measure acceptance tests in Standards Nonresidential Appendices NA7.10 through NA7.16.
- For the leak testing requirement, the installers responsible for the compressed air piping would need to ensure minimal leak loads. Any piping system that does not pass the pressure test during inspection would need repairs of fittings and leaks which are better addressed during the initial install. The pipe installing party would certify completed leak testing.

- **Inspection Phase:** The proposed code change would modify existing acceptance tests but would not require additional documentation. Monitoring function would be verified with an acceptance test performed by the installing field technician similar to the other process measure acceptance tests in Standards Nonresidential Appendices NA7.10 through NA7.16. The acceptance testing outlined in NA7.13 would be performed and The Certificate of Acceptance NRCA-PRC-01-F document would be filled out and signed by the installing field technician. Inspection of pipe sizes would likely not be required, relying instead on the plans review and NRCI-PRC-01-E. Inspectors would verify minimal leak loads by a pressure test similar to one that is already codified for natural gas piping.

Added burdens to compliance officials include plans review, new inspection points, new fields in NRCA-PRC-01-F, and new fields in NRCI-PRC-01-E.

The compliance process described above differs from the existing compliance process in a number of key ways. Specifically, for the design phase, system designers would

need to include metering locations and equipment for required monitoring and pipe diameters and flow rates on plans. The permit phase would only have minor updates, whereas the plans examiner would need to confirm that piping sizes and pressure loss to end uses are within the accepted threshold.

The construction phase differs significantly due to the need for installers to install and commission a monitoring system, then perform a leak test. Likewise, the inspection phase would have updates to acceptance testing and require inspectors to verify minimal leak loads through a pressure test.

While there are a number of substantial changes to the compliance process, the Statewide CASE Team does not expect significant additional burden to compliance actors since many of these processes are part of best practices for compressed air systems. As such, the Statewide CASE Team does not expect there to be additional education required as designers, installers, and inspectors should already be familiar with the processes and/or similar processes.

If this code change proposal is adopted, the Statewide CASE Team recommends that information presented in this section and Section 3, be used to develop compliance documentation and a plan for minimizing barriers to compliance. Additionally, guidance documents and training of field technicians would be required so that compliance data and testing is performed and reported properly.

3. Market Analysis

The Statewide CASE Team performed a market analysis to identify current technology availability and market trends. The Statewide CASE Team then considered how the proposed standard may impact the market in general as well as individual market actors. Information was gathered about the incremental cost of complying with the proposed measure. Estimates of market size and measure applicability were identified through research and outreach with stakeholders including utility program staff, Energy Commission staff, and a wide range of industry actors. In addition to conducting personalized outreach, the Statewide CASE Team discussed the current market structure and potential market barriers during a public stakeholder meeting that the Statewide CASE Team held on November 7, 2019 (California Statewide Utility Codes and Standards Team 2019b).

The Statewide CASE Team also contacted Compressed Air Challenge instructors, compressed air designers, building energy consultants, and compressor, metering and control system manufacturers to obtain their perspectives for incorporation into the market and technical information of this study. The Statewide CASE Team also drew from available literature, technical guides, and other published resources for insight into the compressed air market.

3.1 Market Structure

The compressed air market comprises several key stakeholder categories and any given company can act in multiple stakeholder roles (U.S. Department of Energy 2016):

- **Air compressor manufacturers:** companies that make and sell any type of air compressor or air compressor package.
- **Air compressor auxiliary equipment manufacturers:** companies that produce system equipment such as dryers, filters, coolers, piping, and fittings.
- **Air compressor and equipment distributors:** companies that provide information, bids, and sales of air compressor system components to end users, service providers, or design-build contractors. These distributors may or may not provide design services.
- **Contractors and architect-engineering firms:** companies contracted with end users to provide planning and specifications for the given needs and loads. These firms often lack compressed air specialists.
- **Compressed air system users:** owner-operators of facilities that use compressed air systems, such as manufacturing and healthcare facilities. Often, the end users are responsible for the operation and maintenance of compressed air systems and frequently lack complete training or compressed air specialists.

- **Trade associations** (namely the Compressed Air and Gas Institute and Compressed Air Challenge): organizations of industry representatives who collaborate to promote co-operation amongst stakeholders, provide training and best practices, develop standards, and improve the quality of the compressed air marketplace offerings for the general public.

In addition to these stakeholders, various consultants provide services such as energy efficiency, design services, and performance assessments to proactive end users. The relationships between these stakeholders is shown in Figure 3.

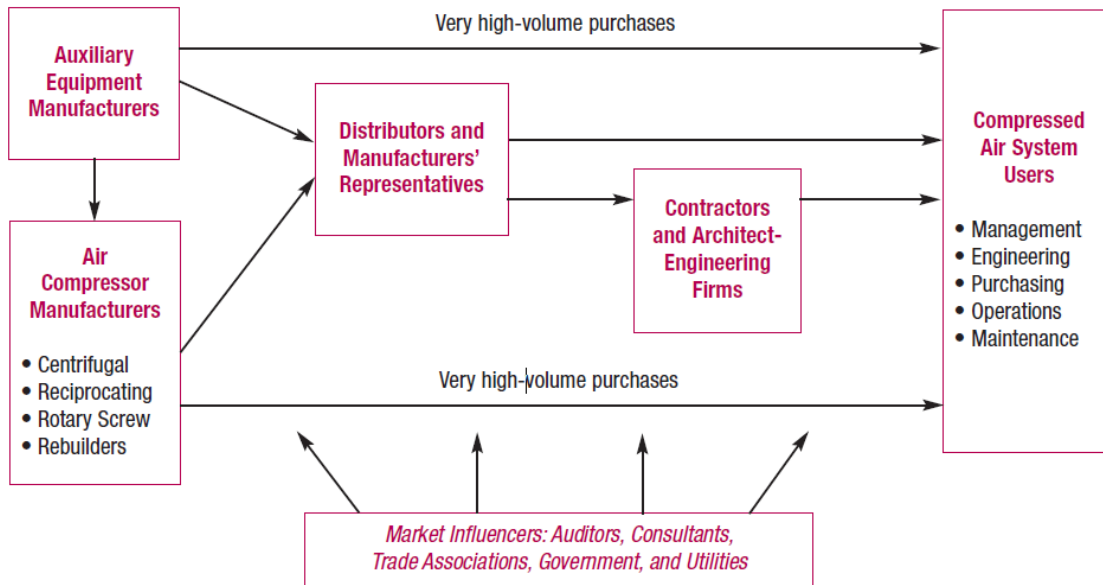

Figure 3: Compressed air system marketplace.

Source: (U.S. Department of Energy 2016)

3.1.1 Pipe Sizing

Distribution and piping system design and installation is conducted by any number of stakeholders. In general, there is no one type of stakeholder than has ownership of the piping system design and installation. The design could be performed by consultants, engineering firms, by in-house end user staff, or otherwise. Similarly, piping installation could be performed by in-house staff or by contracted firms. However, the design principles are consistent regardless of implementer. Several stakeholders have explained that piping can be undersized due a variety of factors:

- Cost-cutting at either the design stage or by installers who install pipes smaller than specified in design documents,
- Lack of knowledge of best design practices or procedures, and
- Load growth that exceeds original loads used in pipe sizing.

3.1.2 Monitoring

Equipment manufacturer and service provider stakeholders provide metering and monitoring product lines. These products and services have been available since roughly 2007. There is sufficient commercial availability of the proposed monitoring requirements for any given situation, new construction or existing buildings. Indeed, air compressor manufacturers are increasingly using onboard metering and monitoring to head off equipment faults, manage field assets, and complement warranties and contract terms. Add-on equipment and cloud-based solutions are also readily available.

Vendors (auxiliary equipment manufacturers) that provide such monitoring products include, but are not limited to, AirLeader, BekoSales, CASE Controls, CDI Meters, Compressed Air Energy Management Systems (CAES), CS Instruments, EcoPlant EnergAir, Enersize, Flexim, Ingersoll Rand, Kaeser Compressors, iZ Systems, LightApp, OmniMetrix, Quincy Scales, Sage Metering, SIGA Compressed Air, SMC Corporation, Sparks Dynamics, Sure Flow, and VPIstruments.

3.1.3 Leak Testing

Leak testing is most often performed by the party who installs the piping. As described in the Pipe Sizing section above, this market actor could be any of a number of stakeholders, including engineering firms, in-house staff, pipefitting contractors, or otherwise.

3.2 Technical Feasibility, Market Availability, and Current Practices

3.2.1 Pipe Sizing – Technical Feasibility

Based on the stakeholder discussions, compressed air piping systems are often appropriately sized in the design phase, especially for large end users. Furthermore, proactive designers often oversize the pipes in anticipation of future load or capacity growth. Best practice guidelines vary, but a maximum of 10 percent total pressure loss from compressor discharge to end use is often quoted. This includes about 5-6 percent loss in aftercoolers, dryers, and filters with the remaining 4-5 percent through the distribution piping to end uses or regulators upstream of end uses. Other guides suggest 1-3 percent pressure drop in the distribution piping is a reasonable target.

To achieve this, reference tables of pressure drop, friction factors, and velocities are typically used in the design process. Equivalent lengths for fittings and bends are also often used to calculate pressure drop. Stakeholders explained that designing for air velocities of 20-30 ft/s and minimizing sharp bends is typically sufficient to achieve minimal frictional pressure drop. To design for minimal pressure drop, designers must know the system pressure and loads (in cfm) which vary throughout the system and depend on end use. There are typically accepted load values for a variety of common

pneumatic end uses and pistons. However, large, custom pneumatic machines are not standardized, and each design must carefully consider the resultant loads and their location in the plant.

3.2.2 Pipe Sizing – Market Availability

Compressed air piping is readily available in the market in different materials and various standard size diameters. There are specific aluminum piping product lines that are marketed towards compressed air systems; otherwise, general piping materials can be used. Different piping materials and product lines would also have varying surface roughness that can impact frictional pressure losses. The compressed air designer typically would specify pipe material and pipe diameter. However, the ultimate decision comes from the facility owner or installer, driven by factors such as the nature of the process in the facility, expertise, and cost of the material and installation. Any compressed air system designer has the tools to minimize pressure drop; availability of best design practices does not need to be a barrier to the proposed measures. Once properly sized, pipe design measure savings will persist throughout the life of the plant unless changes to loads or capacity exceed the original design parameters.

3.2.3 Pipe Sizing – Current Practices

Even if piping designs adhere to best practices, installation can render them moot if installers or the end user opt for reduced size piping to save on material and installation labor costs. Additionally, it is common for existing plants to add compressors, end uses, and sections of pipe which can dramatically affect the discharge pressure requirements if frictional pressure drops are exacerbated. Literature suggests that about 40 percent of existing systems have distribution systems that result in excessive pressure losses (Xenergy, Inc. 2001). Stakeholders repeatedly have stated that design processes vary by firm; although there are accepted best practices and guidelines, there is little standardization across actual designs and the design process. This proposal would help avoid artificial demand from higher than necessary pressure setpoints by requiring the use of recommended pipe sizing design practices.

3.2.4 Monitoring – Technical Feasibility

Aside from the challenges with labor time and cost necessary to address leaks, a primary barrier to proper leak management is lack of visibility into leak loads and repair benefits. As one stakeholder stated, “visibility drives accountability.” Since leaks are a virtually invisible problem, facility managers cannot know what their leak loads are at any given time without some sort of assessment that usually requires the assistance of a specialist or consultant. Similarly, the energy and production benefits from making repairs are also not visible and the return on investment is not easily quantified without targeted data collection. As described in a recent journal article, leak management is

the single largest, most widespread compressed air savings opportunity in a the typical industrial plant and correct handling of compressed air energy consumption requires the management of energy performance indices for the continuous evaluation process (Hernandez-Herrera, et al. 2020).

Currently, energy assessments are performed by contracted consultants and specialists whenever a facility decides to devote resources to their compressed air system. This is most often completed as a reaction to accumulated performance issues or at the prompting of energy program or consultant marketers rather than proactively.

Compressed air assessments have been shown again and again to provide dependable, cost-effective savings through comprehensive evaluation. Among the various opportunities that are regularly identified, negligent leak management is the most common issue and the largest source of potential savings (Hessmer, et al. 2015, Therkelsen, et al. 2015). Monitoring is the logical next step in compressed air energy management, providing streamlined tools and data sources for assessments as well as continuous commissioning in line with ISO 50001 protocols and goals. As described in the Department of Energy's compressed air energy management sourcebook, the first three key elements for a successful leak program are establish a baseline for compressed air usage, establish leak loss, and determine the cost of air leaks (U.S. Department of Energy 2016). All manual and operational corrective actions must follow those crucial first steps, which can be readily achieved through a monitoring system.

As continuous commissioning of industrial facilities and the monitoring-based management of compressed air systems is in the market adoption phase, there are relatively few sources on the relationship between monitoring and energy savings, especially field studies with statistically large populations. However, case studies, stakeholder feedback, and some reports do point to the benefits and inevitability of monitoring use in compressed air continuous energy improvement.

A recent Energy Commission field study of a compressed air monitoring solution found clear, cost-effective benefits and customer satisfaction at 102 participants (Greenstone, et al. 2019). A monitoring system that provided data, trending, and alerts based on the metering points proposed in this report was installed at 102 industrial facilities in California. "The main purpose of the EMS [energy management system] was to enable energy optimization by acquiring high resolution energy consumption data in real-time, identifying and generating insights from the data (i.e., identify and calculate leakage), and triggering alerts and actions for the facility's staff." A regression analysis of the randomized control trial with a blind baseline and post-period showed savings of about 6,292,000 kWh/year at the sites due to their behavioral response to visualizations, data, and alerts. Extrapolation of these empirical findings to the total California industrial compressed air usage would suggest a potential statewide savings of about 129 GWh/year. These savings would materialize from leak management and other

corrective actions aimed at maintaining total system efficiency. Of the 102 participants, 41 percent opted to purchase continued monitoring services of their own accord after the year-long post-period.

Aside from this large-scale field study, there have been a several published case studies on the benefits of monitoring in compressed air systems. The Department of Energy Better Buildings Program helped implement an ISO 50001-based approach at a Johnson Controls facility that included a web-based monitoring system with metering of flow, pressure, and compressor current (U.S. Department of Energy n.d.). These monitoring data were used to help diagnose issues and sustain energy savings of 39 percent, largely due to leak repair. For instance, flow and pressure meter data helped pinpoint multiple air leaks inside bag houses that could not otherwise be seen or heard.

In another case study of monitoring applied at a pharmaceutical manufacturing facility, monitoring was shown to prompt maintenance and corrective actions that saved 10 percent of compressed air energy consumption. As stated, “the work also demonstrates that measurement of actual operative conditions are crucial to characterize the energy consumption related to compressed air generation... This paper shows the importance of monitoring energy consumption and control energy use in compressed air generation, to enable energy savings practices, enhance the outcomes of energy management projects, and to guide industries in energy management,” (Bonfa, et al. 2018).

Another recent online article on the benefits of compressed air monitoring described leak management behavioral response at an industrial facility that had intermittent loads exceeding 10,000 cfm (Hoetzel n.d.). An installed monitoring system showed a leak load of about 3,500 cfm through clear trend data and after-hours consumption. The scale of waste was so much greater than anticipated that facility staff immediately implemented corrective actions and established permanent leak management strategies based on alerts of load growth beyond expected baseline values. In this case, the monitoring system was necessary to establish the financial opportunity and return-on-investment that drove the corrective actions.

Compressed air monitoring systems have benefits far beyond just leak management. Monitoring can and should be leveraged to monitoring system pressure, performance, and specific efficiency. These data can show many opportunities for optimization beyond leak repair and help realize the energy benefits of the existing control and trim code requirements. A recent article describes cases where monitoring trend data and alerts identified such situations (Marshall 2017). In one case a compressor room was operating at over six times the expected energy intensity because a dryer had an unidentified mechanical issue that had been blowing off excess air for an unknown amount of time. In another case monitoring showed that a poorly applied controller and compressor sizing had been operating two compressors during periods of light loading when only one would have sufficed. Yet another case study from Australia described

two situations in which monitoring systems identified poor controller programming after compressor replacements that were wasting \$10,000 and \$22,000 per year in energy costs at a meat processing plant and sawmill (Rampley and Marshall 2020). In all of these facilities, monitoring was necessary to identify the ongoing, unseen issues and would have immediately made them visible should monitoring have been installed in the first place.

In general, there are few technical barriers to implementing monitoring in any given system. While some compressor manufacturers offer controllers or compressor package options that would satisfy the proposed measures, there are also modular, cloud-based products that can be added to any existing or proposed system. As such, the available products can satisfy the proposed requirements for virtually any covered scenario.

There has been a historical market perception that flow metering can be unreliable and inaccurate, but subject matter expert stakeholders have explained that this is an outdated perspective and that available technology can render these concerns moot if properly selected, installed, and maintained. Flow metering is a regularly recommended good practice without prohibitive market or technical barriers. Flow meters are available for both dry and wet air; wet air metering has been available since roughly 2009 and although stakeholders have claimed acceptable wet air metering reliability and accuracy, others are still suspect. Stakeholders have explained that although a portion of the market perceives wet air flow as problematic, proper metering location and installation would avoid any potential problems. If possible, flow meters should be installed after dryers, drains, and filters to mitigate moisture and buildup, after sufficient straight pipe length to fully develop turbulent flow profiles, angled to allow condensation and moisture to drop off sensors, and wet air compatible meters should be used when dryers are not present or at compressor discharge locations. For example, thermal mass meters are not compatible with wet air while differential pressure meters can be. Although some stakeholders have explained that calibration is not typically an issue or ongoing requirement, it is prudent to assume that it is a recommended best practice for reliable measurement and savings benefits. Flowmeters, such as thermal mass meters, can change sensitivity due to fouling of the sensor from airflow constituents such as oil or sticky particles.

The proposed code language also allows for indirect determination of airflow and load without direct flow metering. Performance data and laboratory-certified testing of compressor models provides a relationship between air flow, compressor power, and operating conditions. Monitoring systems and controllers can use compressor load fractions, power, and pressure to determine flowrates. This indirect determination of flow rates is industry standard and as widely accepted as direct flow metering. Since both are a viable way to monitor flow rates and total system loads, both are allowed in

the proposed code language. Either option should enable the same system-level view and monitoring of loads, as the proposal intends. Allowing for each method of load monitoring will ensure product availability across all applications, avoid excluding market solutions and vendors, and allow flexible compliance with the proposed measure.

3.2.5 Monitoring – Market Availability

Monitoring of a compressed air system can help address some of these barriers by providing alerts, tracking, and KPIs which quantify leak loads, load growth, and changes in energy consumption. Further benefits of monitoring systems include tracking of system efficiency that is coupled with other events and potential corrective actions, fault detection, runtimes, production patterns, and other insights into the system and plant operation. Any system including load monitoring can be leveraged into tracking load growth or leak load identification. Similarly, system efficiency tracking is also available through use of compressor current or power metering in conjunction with air flow metering.

Monitoring is not currently an industry standard practice but adoption is increasing as options and availability expand and as costs decline. The products and providers listed in Section 3.1 can provide the necessary equipment and installation for customers throughout California. Metering of pressure (used as the control parameter in most systems) and dewpoint (for systems with dryers) is currently the only industry standard practice in most scenarios. Particularly large systems, especially those with centrifugal compressors, often have metering of flowrates or power, but it is not clear whether this is industry standard practice or not. One stakeholder explained that many proactive energy managers and designers do not entertain bids for systems without monitoring and that monitoring is the next big thing in compressed air; naturally occurring adoption is expected.

Flow meters come in a variety of forms: ultrasonic, clamp-on, orifice, insertion, thermal mass, in-line, etc. For instance, a single meter product can include multiple measurements (e.g., flow, pressure, and temperature). This proposal does not intend to specify flowmeter requirements or design. This would allow for flexible design solutions and avoid impacting natural market competition and innovation. That said, there are some flowmeter types that are detrimental from an efficiency perspective (such as orifice meters which carry a heavy pressure drop penalty).

Metering of compressor power can be accomplished using either current metering (e.g., current transducers) or real power measurement. Again, this proposal does not specify exact power metering requirements in order to allow for design flexibility since the goals of the proposed code can be achieved with any number of metering solutions.

In addition to airflow and power, monitoring systems can incorporate metering of dew point, temperature, pressure, and other points. Algorithms and data management in monitoring software can use this data to track any number of KPIs, including the load and specific power required in the proposed measures.

3.2.6 Monitoring – Current Practices

Leaks and leak management have been problematic for compressed air stakeholders as long as there has been compressed air. Leaks develop through aging equipment, degrading seals, vibration, poor pneumatic component installations, and, to a certain extent, leaks that may have been missed during initial piping installation.

Recommended best practice is to establish a leak prevention and repair program that is designed to avoid, identify, track, and repair leaks either continuously or periodically. Despite this recommendation being widely known by end users and operators, leak management practice is not widespread and does not receive the attention it warrants. Currently, leaks are rarely addressed in a timely fashion; only 35-40 percent of end users have leak prevention programs (Xenergy, Inc. 2001, Saidur, Rahim and Hasanuzzaman 2009, Hernandez-Herrera, et al. 2020). As a result, leaks typically account for 20-30 percent of system load in industrial settings even though acceptable thresholds are typically around 5-10 percent (U.S. Department of Energy 2004, Amon, Moskowitz and Kazama 2013, U.S. Department of Energy 2016). Similarly, stakeholders and references state that cost-effective leak targets are typically about 10 percent.

Although leak management best practices have yet to be fully realized in the industry, new tools and protocols are helping drive the market towards better efficiency. Industrial markets are realizing the benefits of continuous improvement on energy expenses through protocols such as ISO 50001 and initiatives such as the Department of Energy's Better Buildings Program. As an example of this, the Lawrence Berkeley National Laboratory showed clear energy cost payback from ISO 50001 protocols across multiple industrial sites using energy management systems (Therkelsen, et al. 2015). Since compressed air is such a large, inefficient fraction of industrial energy use, it must be part of any adoption in such continuous improvement practices. The Department of Energy specifically calls out ongoing monitoring of compressed air energy performance as a key part of energy management systems in industrial settings (U.S. Department of Energy 2016). To do this, key metrics are crucial to proper implementation. As described in a compressed air ISO 50001 article and in other monitoring standards, there are several KPIs that must be included in compressed air continuous improvement enabled by measurement of compressor power, air flow, and pressure (Marshall n.d., CSA Group 2016). Generally, none of these KPIs are tracked by most facilities without energy management systems and only have visibility to these

metrics during the occasional assessment provided by compressed air specialists and consultants.

3.2.7 Leak Testing – Technical Feasibility

While monitoring is aimed at tracking performance and wasteful load growth over time, leaks may be present upon installation of new piping. To track leak loads and load growth over time, a proper baseline needs to be established or visible in the data trending. Ensuring minimal leak load at installation of new piping is not only best practice to avoid leaks, it can also help establish this baseline for trending comparison over time. Furthermore, leaks that develop over time are usually near the end uses where most fittings, use, and vibrations occur. Leaks in header piping, interconnection piping, and risers are more difficult to address and access once a plant is operational. Any leaks present at installation should be identified and fixed prior to plant start-up.

Leak testing at construction can be performed in a number of different ways: using leak detection fluid at joints and fittings, observing flowmeter outputs, observing compressor loading, or observing pressure decrease in a system once pressurized. In each case, the test requires pressurizing the system with a test fluid, namely compressed air. Stakeholders have explained that test practices vary from firm to firm, although any distribution system would have valves and caps that can enable any type of required test.

3.2.8 Leak Testing – Market Availability

Any pipe installation contractor could perform leak testing without training or significant burden. It is a best practice and there is no barrier to performing basic leak testing as proposed in the code language. The proposed compliance process would allow the installing contractor or entity act as the qualified leak test individual in lieu of an acceptance test technician (ATT). There are several specific guidelines for leak testing of compressed air that can be used to estimate exact leak loads. However, this proposal is limiting itself to recommending an easier replication of pressure testing in the natural gas piping code.

3.2.9 Monitoring and Leak Testing – Current Practices

Although leak testing of new piping installations is a best practice, stakeholders have explained that not all installers complete comprehensive leak testing and acceptance thresholds would often depend on agreements between the end user and contractor. While the majority of new installations would likely be tested and have minimal leakage, codifying the practice can entrain bad actors into this best practice and help establish a clear baseline for ongoing monitoring.

3.3 Market Impacts and Economic Assessments

3.3.1 Impact on Builders

Builders of residential and commercial structures are directly impacted by many of the measures proposed by the Statewide CASE Team for the 2022 code cycle. It is within the normal practices of these businesses to adjust their building practices to changes in building codes. When necessary, builders engage in continuing education and training in order to remain compliant with changes to design practices and building codes.

California's construction industry is comprised of about 80,000 business establishments and 860,000 employees (see Table 4).¹ In 2018, total payroll was \$80 billion.

Approximately 17,000 establishments and 344,000 employees focus on the commercial sector. The remainder of establishments and employees work in industrial, utilities, infrastructure, and other heavy construction (industrial sector).

¹ Average total monthly employment in California in 2018 was 18.6 million; the construction industry represented 4.5 percent of 2018 employment.

Table 4: California Construction Industry, Establishments, Employment, and Payroll

Construction Sectors	Establishments	Employment	Annual Payroll (billions \$)
Residential	59,287	420,216	\$23.3
Residential Building Construction Contractors	22,676	115,777	\$7.4
Foundation, Structure, & Building Exterior	6,623	75,220	\$3.6
Building Equipment Contractors	14,444	105,441	\$6.0
Building Finishing Contractors	15,544	123,778	\$6.2
Commercial	17,273	343,513	\$27.8
Commercial Building Construction	4,508	75,558	\$6.9
Foundation, Structure, & Building Exterior	2,153	53,531	\$3.7
Building Equipment Contractors	6,015	128,812	\$10.9
Building Finishing Contractors	4,597	85,612	\$6.2
Industrial, Utilities, Infrastructure, & Other	4,103	96,550	\$9.2
Industrial Building Construction	299	5,864	\$0.5
Utility System Construction	1,643	47,619	\$4.3
Land Subdivision	952	7,584	\$0.9
Highway, Street, and Bridge Construction	770	25,477	\$2.4
Other Heavy Construction	439	10,006	\$1.0

Source: (State of California, Employment Development Department n.d.)

The proposed change to compressed air system requirements would likely affect non-residential. The effects on the commercial building industry would not be felt by all firms and workers, but rather would be concentrated in specific industry subsectors. Table 5 shows the commercial building subsectors the Statewide CASE Team expects to be impacted by the changes proposed in this report. The monitoring measure would primarily affect compressed air contractors and electricians while the pipe sizing and leak testing measures would affect piping designers and contractors. The Statewide CASE Team’s estimates of the magnitude of these impacts are shown in Section 3.4 Economic Impacts.

Table 5: Specific Subsectors of the California Commercial Building Industry Impacted by Proposed Change to Code

Construction Subsector	Establishments	Employment	Annual Payroll (billions \$)
Nonresidential Electrical Contractors	3,115	66,951	\$5.61
Nonresidential plumbing and HVAC contractors	2,394	52,977	\$4.47
Other Nonresidential equipment contractors	506	8,884	\$0.86
All other Nonresidential trade contractors	988	17,960	\$1.40

Source: (State of California, Employment Development Department n.d.)

3.3.2 Impact on Building Designers and Energy Consultants

Adjusting design practices to comply with changing building codes practices is within the normal practices of building designers. Building codes (including the California Energy Code) are typically updated on a three-year revision cycle and building designers and energy consultants engage in continuing education and training in order to remain compliant with changes to design practices and building codes.

Businesses that focus on residential, commercial, institutional, and industrial building design are contained within the Architectural Services sector (North American Industry Classification System 541310). Table 6 shows the number of establishments, employment, and total annual payroll for Building Architectural Services. The proposed code changes would potentially impact all firms within the Architectural Services sector. The Statewide CASE Team anticipates the impacts for compressed air requirements to affect firms that focus on elements of non-residential and industrial design construction.

There is not a North American Industry Classification System (NAICS)² code specific for energy consultants. Instead, businesses that focus on consulting related to building

² NAICS is the standard used by Federal statistical agencies in classifying business establishments for the purpose of collecting, analyzing, and publishing statistical data related to the U.S. business economy. NAICS was developed jointly by the U.S. Economic Classification Policy Committee (ECPC), Statistics Canada, and Mexico's Instituto Nacional de Estadística y Geografía, to allow for a high level of comparability in business statistics among the North American countries. NAICS replaced the Standard Industrial Classification (SIC) system in 1997.

energy efficiency are contained in the Building Inspection Services sector (NAICS 541350), which is comprised of firms primarily engaged in the physical inspection of residential and nonresidential buildings.³ It is not possible to determine which business establishments within the Building Inspection Services sector are focused on energy efficiency consulting. The information shown in Table 6 provides an upper bound indication of the size of this sector in California.

Table 6: California Building Designer and Energy Consultant Sectors

Sector	Establishments	Employment	Annual Payroll (billions \$)
Architectural Services ^a	3,704	29,611	\$2.91
Building Inspection Services ^b	824	3,145	\$0.22

Source: (State of California, Employment Development Department n.d.)

- a. Architectural Services (NAICS 541310) comprises private-sector establishments primarily engaged in planning and designing residential, institutional, leisure, commercial, and industrial buildings and structures;
- b. Building Inspection Services (NAICS 541350) comprises private-sector establishments primarily engaged in providing building (residential & nonresidential) inspection services encompassing all aspects of the building structure and component systems, including energy efficiency inspection services.

3.3.3 Impact on Occupational Safety and Health

The proposed code change does not alter any existing federal, state, or local regulations pertaining to safety and health, including rules enforced by Cal/OSHA. All existing health and safety rules would remain in place. Compliance with the proposed code change is not anticipated to have adverse impacts on the safety or health of occupants, or those involved with the construction, commissioning, and maintenance of the building.

The environmental health and safety (EH&S) departments of each facility often develop operations and maintenance protocols that cover the compressed air system. In cases wherein new monitoring equipment are installed as part of the Title 24, Part 6 changes,

³ Establishments in this sector include businesses primarily engaged in evaluating a building’s structure and component systems and includes energy efficiency inspection services and home inspection services. This sector does not include establishments primarily engaged in providing inspections for pests, hazardous wastes or other environmental contaminants, nor does it include state and local government entities that focus on building or energy code compliance/enforcement of building codes and regulations.

then EH&S protocol would require revision to cover operating parameters and safety procedures of the monitoring equipment.

The proposed requirements would apply to healthcare facilities.

3.3.4 Impact on Building Owners and Occupants

The proposed change to the code is expected to increase the incremental first costs for building owners and additional maintenance costs over the lifetime of the measures. Compressed air end users may experience an adjustment period while becoming accustomed to the operation of the new monitoring equipment and data storage maintenance.

Commercial Buildings

The commercial building sector includes a wide array of building types, including offices, restaurants and lodging, retail, and mixed-use establishments, and warehouses (including refrigerated) (Kenney 2019). Energy use by occupants of commercial buildings also varies considerably with electricity used primarily for lighting, space cooling and conditioning, and refrigeration. Natural gas consumed primarily for heating water and for space heating. According to information published in the 2019 California Energy Efficiency Action Plan, there is more than 7.5 billion square feet of commercial floor space in California and consumes 19 percent of California's total annual energy use (Kenney 2019). The diversity of building and business types within this sector creates a challenge for disseminating information on energy and water efficiency solutions, as does the variability in sophistication of building owners and the relationships between building owners and occupants.

Industrial Buildings

The industrial building sector includes a wide array of building types, including factories, oil refineries, power generating facilities, slaughterhouses, and other facilities that primarily focus on manufacturing, processing, or assembly. Energy use in industrial buildings also varies considerably with electricity used for lighting, space cooling and conditioning, and refrigeration. Most electricity used in the industrial sector is purchased from utilities or other independent generators, but some industrial facilities also produce electricity either directly from other fuels or as a byproduct of their industrial processes. Industrial buildings use natural gas for heating water and for space heating. According to information published in the 2019 California Energy Efficiency Action Plan, the industrial sector (including agriculture) is responsible for 23 percent of California's total annual energy use (Kenney 2019). Most of this energy is used in industrial processes and the 2019 California Energy Efficiency Action Plan does not attempt to estimate the relatively small proportion of industrial energy used for lighting, water and space heating, or other building-specific purposes. The diversity of building and business types

within this sector creates a challenge for disseminating information on energy and water efficiency solutions.

Estimating Impacts

Building owners and occupants will benefit from lower energy bills. As discussed in Section 3.4.1, when building occupants save on energy bills, they tend to spend it elsewhere in the economy thereby creating jobs and economic growth for the California economy. The Statewide CASE Team does not expect the proposed code change for the 2022 code cycle to impact building owners or occupants adversely.

3.3.5 Impact on Building Component Retailers (Including Manufacturers and Distributors)

The proposed code change would increase sales for the manufacturers and distributors of metering and monitoring equipment. IoT companies may also increase sales in order for customers to maintain data storage of the monitored equipment.

3.3.6 Impact on Building Inspectors

As a result of the proposed measure, there would be an update to the NA7.13 Compressed Air Acceptance Tests that adds to the list of compliance checks for the plan examiner and building inspector. The inclusion of the new acceptance test for metering accuracy would require a field technician to perform the functional testing and complete and sign the corresponding compliance documents to ensure the measure meets the acceptance requirements specified in NA7.13.3. The addition to the Nonresidential Certificate of Acceptance document may require additional inspection time for the plans examiner and building inspector to verify compliance.

Table 7 shows employment and payroll information for state and local government agencies in which many inspectors of residential and commercial buildings are employed. Building inspectors participate in continuing training to stay current on all aspects of building regulations, including energy efficiency. The Statewide CASE Team, therefore, anticipates the proposed change would have no impact on employment of building inspectors or the scope of their role conducting energy efficiency inspections.

Table 7: Employment in California State and Government Agencies with Building Inspectors

Sector	Govt.	Establishments	Employment	Annual Payroll (millions \$)
Administration of Housing Programs ^a	State	17	283	\$29.0
	Local	36	2,882	\$205.7
Urban and Rural Development Admin ^b	State	35	552	\$48.2
	Local	52	2,446	\$186.6

Source: (State of California, Employment Development Department n.d.)

- a. Administration of Housing Programs (NAICS 925110) comprises government establishments primarily engaged in the administration and planning of housing programs, including building codes and standards, housing authorities, and housing programs, planning, and development.
- b. Urban and Rural Development Administration (NAICS 925120) comprises government establishments primarily engaged in the administration and planning of the development of urban and rural areas. Included in this industry are government zoning boards and commissions.

3.3.7 Impact on Statewide Employment

The Statewide CASE Team does not expect the addition or elimination of jobs as a result of the proposed measures. In large part, the proposed changes are simply adjustments to already proceeding work. As described in Sections 3.3.1 through 3.3.6, the Statewide CASE Team does not anticipate significant employment or financial impacts to any particular sector of the California economy. This is not to say that the proposed change would not have modest impacts on employment in California. In Section 3.4, the Statewide CASE Team estimated the proposed change in compressed air requirements would affect statewide employment and economic output directly and indirectly through its impact on builders, designers and energy consultants, and building inspectors. In addition, the Statewide CASE Team estimated how energy savings associated with the proposed changes would lead to modest ongoing financial savings for California residents, which would then be available for other economic activities.

3.4 Economic Impacts

For the 2022 code cycle, the Statewide CASE Team used the IMPLAN model software, along with economic information from published sources, and professional judgement to developed estimates of the economic impacts associated with each proposed code

changes.⁴ While this is the first code cycle in which the Statewide CASE Team develops estimates of economic impacts using IMPLAN, it is important to note that the economic impacts developed for this report are only estimates and are based on limited and to some extent speculative information. In addition, the IMPLAN model provides a relatively simple representation of the California economy and, though the Statewide CASE Team is confident that direction and approximate magnitude of the estimated economic impacts are reasonable, it is important to understand that the IMPLAN model is a simplification of extremely complex actions and interactions of individual, businesses, and other organizations as they respond to changes in energy efficiency codes. In all aspect of this economic analysis, the CASE Authors rely on conservative assumptions regarding the likely economic benefits associated with the proposed code change. By following this approach, the Statewide CASE Team believes the economic impacts presented below represent lower bound estimates of the actual impacts associated with this proposed code change.

Adoption of this code change proposal would result in relatively modest economic impacts through the additional direct spending by those in the commercial and industrial building industry, architects, energy consultants, and building inspectors. The Statewide CASE Team does not anticipate that money saved by commercial building owners or other organizations affected by the proposed 2022 code cycle regulations would result in additional spending by those businesses.

⁴ IMPLAN (Impact Analysis for Planning) software is an input-output model used to estimate the economic effects of proposed policies and projects. IMPLAN is the most commonly used economic impact model due to its ease of use and extensive detailed information on output, employment, and wage information.

Table 8: Estimated Impact that Adoption of the Proposed Measure would have on the California Commercial Construction Sector – Pipe Sizing

Type of Economic Impact	Employment (jobs)	Labor Income (millions \$)	Total Value Added (millions \$)	Output (millions \$)
Direct Effects (Additional spending by Commercial Builders)	47	\$3.09	\$4.09	\$6.77
Indirect Effect (Additional spending by firms supporting Commercial Builders)	10	\$0.74	\$1.18	\$2.27
Induced Effect (Spending by employees of firms experiencing “direct” or “indirect” effects)	20	\$1.14	\$2.05	\$3.34
Total Economic Impacts	77	\$4.97	\$7.31	\$12.38

Source: Analysis by Evergreen Economics of data from the IMPLAN V3.1 modeling software.

Table 9: Estimated Impact that Adoption of the Proposed Measure would have on the California Commercial Construction Sector – Leak Testing

Type of Economic Impact	Employment (jobs)	Labor Income (millions \$)	Total Value Added (millions \$)	Output (millions \$)
Direct Effects (Additional spending by Commercial Builders)	3	\$0.20	\$0.26	\$0.43
Indirect Effect (Additional spending by firms supporting Commercial Builders)	1	\$0.05	\$0.08	\$0.15
Induced Effect (Spending by employees of firms experiencing “direct” or “indirect” effects)	1	\$0.07	\$0.13	\$0.21
Total Economic Impacts	5	\$0.32	\$0.47	\$0.79

Source: Analysis by Evergreen Economics of data from the IMPLAN V3.1 modeling software.

Table 10: Estimated Impact that Adoption of the Proposed Measure would have on the California Commercial Construction Sector – Leak Monitoring

Type of Economic Impact	Employment (jobs)	Labor Income (millions \$)	Total Value Added (millions \$)	Output (millions \$)
Direct Effects (Additional spending by Commercial Builders)	35	\$2.28	\$3.03	\$5.00
Indirect Effect (Additional spending by firms supporting Commercial Builders)	8	\$0.55	\$0.87	\$1.68
Induced Effect (Spending by employees of firms experiencing “direct” or “indirect” effects)	15	\$0.85	\$1.51	\$2.47
Total Economic Impacts	58	\$3.68	\$5.41	\$9.15

Source: Analysis by Evergreen Economics of data from the IMPLAN V3.1 modeling software.

Table 11: Estimated Impact that Adoption of the Proposed Measure would have on the California Building Designers and Energy Consultants Sectors – Pipe Sizing

Type of Economic Impact	Employment (jobs)	Labor Income (millions \$)	Total Value Added (millions \$)	Output (millions \$)
Direct Effects (Additional spending by Building Designers & Energy Consultants)	8	\$0.87	\$0.86	\$1.53
Indirect Effect (Additional spending by firms supporting Bldg. Designers & Energy Consult.)	5	\$0.36	\$0.48	\$0.77
Induced Effect (Spending by employees of firms experiencing “direct” or “indirect” effects)	7	\$0.37	\$0.66	\$1.07
Total Economic Impacts	20	\$1.60	\$2.00	\$3.37

Source: Analysis by Evergreen Economics of data from the IMPLAN V3.1 modeling software.

Table 12: Estimated Impact that Adoption of the Proposed Measure would have on the California Building Designers and Energy Consultants Sectors – Leak Monitoring

Type of Economic Impact	Employment (jobs)	Labor Income (millions \$)	Total Value Added (millions \$)	Output (millions \$)
Direct Effects (Additional spending by Building Designers & Energy Consultants)	0	\$0.03	\$0.03	\$0.05
Indirect Effect (Additional spending by firms supporting Bldg. Designers & Energy Consult.)	0	\$0.01	\$0.02	\$0.03
Induced Effect (Spending by employees of firms experiencing “direct” or “indirect” effects)	0	\$0.01	\$0.02	\$0.04
Total Economic Impacts	0	\$0.05	\$0.07	\$0.11

Source: Analysis by Evergreen Economics of data from the IMPLAN V3.1 modeling software.

Table 13: Estimated Impact that Adoption of the Proposed Measure would have on California Building Inspectors – Pipe Sizing

Type of Economic Impact	Employment (jobs)	Labor Income (millions \$)	Total Value Added (millions \$)	Output (millions \$)
Direct Effects (Additional spending by Building Inspectors)	0	\$0.01	\$0.01	\$0.01
Indirect Effect (Additional spending by firms supporting Building Inspectors)	0	\$0.00	\$0.00	\$0.00
Induced Effect (Spending by employees of Building Inspection Bureaus and Departments)	0	\$0.00	\$0.00	\$0.01
Total Economic Impacts	0	\$0.01	\$0.01	\$0.02

Source: Analysis by Evergreen Economics of data from the IMPLAN V3.1 modeling software.

Table 14: Estimated Impact that Adoption of the Proposed Measure would have on California Building Inspectors – Leak Testing

Type of Economic Impact	Employment (jobs)	Labor Income (millions \$)	Total Value Added (millions \$)	Output (millions \$)
Direct Effects (Additional spending by Building Inspectors)	0	\$0.00	\$0.01	\$0.01
Indirect Effect (Additional spending by firms supporting Building Inspectors)	0	\$0.00	\$0.00	\$0.00
Induced Effect (Spending by employees of Building Inspection Bureaus and Departments)	0	\$0.00	\$0.00	\$0.00
Total Economic Impacts	0	\$0.00	\$0.01	\$0.01

Source: Analysis by Evergreen Economics of data from the IMPLAN V3.1 modeling software.

Table 15: Estimated Impact that Adoption of the Proposed Measure would have on California Building Inspectors – Leak Monitoring

Type of Economic Impact	Employment (jobs)	Labor Income (millions \$)	Total Value Added (millions \$)	Output (millions \$)
Direct Effects (Additional spending by Building Inspectors)	0	\$0.03	\$0.03	\$0.04
Indirect Effect (Additional spending by firms supporting Building Inspectors)	0	\$0.00	\$0.00	\$0.00
Induced Effect (Spending by employees of Building Inspection Bureaus and Departments)	0	\$0.01	\$0.02	\$0.03
Total Economic Impacts	0	\$0.04	\$0.05	\$0.07

Source: Analysis by Evergreen Economics of data from the IMPLAN V3.1 modeling software.

3.4.1 Creation or Elimination of Jobs

The Statewide CASE Team does not anticipate that the measures proposed for the 2022 code cycle regulation would lead to the creation of new *types* of jobs or the elimination of *existing* types of jobs. In other words, the Statewide CASE Team’s

proposed change would not result in economic disruption to any sector of the California economy. Rather, the estimates of economic impacts discussed in Section 3.4 would lead to modest changes in employment of existing jobs.

3.4.2 Creation or Elimination of Businesses in California

As stated in Section 3.4.1, the Statewide CASE Team's proposed change would not result in economic disruption to any sector of the California economy. The proposed changes represent modest changes to compressed air system design, installation, and commissioning, which would not excessively burden or competitively disadvantage California businesses – nor would it necessarily lead to a competitive advantage for California businesses. Therefore, the Statewide CASE Team does not foresee any new businesses being created, nor does the Statewide CASE Team think any existing businesses would be eliminated due to the proposed code changes.

3.4.3 Competitive Advantages or Disadvantages for Businesses in California

The proposed code changes would apply to all businesses incorporated in California, regardless of whether the business is incorporated inside or outside of the state.⁵ Therefore, the Statewide CASE Team does not anticipate that these measures proposed for the 2022 code cycle regulation would have an adverse effect on the competitiveness of California businesses. Likewise, the Statewide CASE Team does not anticipate businesses located outside of California would be advantaged or disadvantaged.

3.4.4 Increase or Decrease of Investments in the State of California

The Statewide CASE Team analyzed national data on corporate profits and capital investment by businesses that expand a firm's capital stock (referred to as net private domestic investment, or NPDI).⁶ As Table 16 shows, between 2015 and 2019, NPDI as a percentage of corporate profits ranged from 26 to 35 percent, with an average of 31 percent. While only an approximation of the proportion of business income used for net capital investment, the Statewide CASE Team believes it provides a reasonable

⁵ Gov. Code, § 11346.3(c)(1)(C), 11346.3(a)(2); 1 CCR § 2003(a)(3) Competitive advantages or disadvantages for California businesses currently doing business in the state.

⁶ Net private domestic investment is the total amount of investment in capital by the business sector that is used to expand the capital stock, rather than maintain or replace due to depreciation. Corporate profit is the money left after a corporation pays its expenses.

estimate of the proportion of proprietor income that would be reinvested by business owners into expanding their capital stock.

Table 16: Net Domestic Private Investment and Corporate Profits, U.S.

Year	Net Domestic Private Investment by Businesses, Billions of Dollars	Corporate Profits After Taxes, Billions of Dollars	Ratio of Net Private Investment to Corporate Profits
2015	609.3	1,740.4	35%
2016	456.0	1,739.8	26%
2017	509.3	1,813.6	28%
2018	618.3	1,843.7	34%
2019	580.9	1,827.0	32%
		5-Year Average	31%

Source: (Federal Reserve Economic Data n.d.)

The Statewide CASE Team does not anticipate that the economic impacts associated with the proposed measure would lead to significant change (increase or decrease) in investment in any directly or indirectly affected sectors of California’s economy. Nevertheless, the Statewide CASE Team is able to derive a reasonable estimate of the change in investment by California businesses by multiplying the sum of Business Income estimated in the tables above by 31 percent which yields a net increase of about \$4,569,999 per year.

3.4.5 Effects on the State General Fund, State Special Funds, and Local Governments

The Statewide CASE Team does not expect the proposed code changes would have a measurable impact on the California’s General Fund, any state special funds, or local government funds.

3.4.5.1 Cost of Enforcement

Cost to the State

State government already has budget for code development, education, and compliance enforcement. While state government will be allocating resources to update the Title 24, Part 6 Standards, including updating education and compliance materials and responding to questions about the revised requirements, these activities are already covered by existing state budgets. The costs to state government are small when compared to the overall costs savings and policy benefits associated with the code change proposals. The proposed measures are not expected to affect virtually any state buildings.

Cost to Local Governments

All proposed code changes to Title 24, Part 6 would result in changes to compliance determinations. Local governments would need to train building department staff on the revised Title 24, Part 6 Standards. While this re-training is an expense to local governments, it is not a new cost associated with the 2022 code change cycle. The building code is updated on a triennial basis, and local governments plan and budget for retraining every time the code is updated. There are numerous resources available to local governments to support compliance training that can help mitigate the cost of retraining, including tools, training and resources provided by the IOU Codes and Standards program (such as Energy Code Ace). As noted in Section 2.5 and Appendix C, the Statewide CASE Team considered how the proposed code change might impact various market actors involved in the compliance and enforcement process and aimed to minimize negative impacts on local governments.

3.4.6 Impacts on Specific Persons

While the objective of any of the Statewide CASE Team's proposal is to promote energy efficiency, the Statewide CASE Team recognizes that there is the potential that a proposed code change may result in unintended consequences. Despite this potential consequence, the Statewide CASE Team does not expect any impact on specific persons or demographics. The proposed measures impact only industrial design and construction and should not have any impacts other than energy usage and production efficiency, once implemented.

4. Energy Savings

The energy and cost analysis presented in this report is consistent with the TDV factors presented during the Energy Commission's March 27, 2020 workshop on compliance metrics (California Energy Commission 2020). The electricity TDV factors include the 15 percent retail adder and the natural gas TDV factors include the impact of methane leakage on the building site. The electricity TDV factors used in the energy savings analyses were obtained from Energy and Environmental Economics, Inc. (E3), the contractor that is developing the 2022 TDV factors for the Energy Commission, in a spreadsheet titled "Electric TDVs 2022 - 15 pct Retail Adj Scaled by Avoided Costs.xlsx". The natural gas TDV factors used in the energy savings analyses were obtained from E3 in a spreadsheet titled "2022_TDV_Policy_Compliant_CH4Leak_FlatRtlAdd_20191210.xlsx". The electricity demand factors used in the energy savings analysis were obtained from E3 in a spreadsheet titled "2022 TDV Demand Factors.xlsx". The final TDV factors that the Energy Commission released in June 2020 use 20-year global warming potential (GWP) values instead of the 100-year GWP values that were used to derive the current TDV factors. The 20-year GWP values increased the TDV factors slightly. Energy savings presented in kWh and therms are not affected by TDV or demand factors.

To estimate energy savings, the Statewide CASE Team used AirMaster+ to model hourly energy use from representative compressed air systems operating under specific load profiles. The representative compressed air systems and load profiles are based on 2013 Final CASE Report code change efforts. The pipe sizing and leak management measures are overlaid on top of the prototype models established for the 2013 effort. AirMaster+ was developed as part of the Department of Energy's Industrial Technology Program. The outputs of the AirMaster+ models are compressor power on an hourly basis.

For the leak reduction analysis, the prototype systems were modeled with leak loads between 10 and 20 percent in two percent increments. Prototype system energy was calculated for each increment of leak load so that a relationship between energy usage and leak load could be established. From this, savings were calculated for each leak load reduction level.

For the system pressure reduction analysis, a set of models were created with inherent piping pressure losses of 0-10 psig above the operating system pressure of 100 psig. These model runs were used to establish a relationship between energy usage and pressure loss (and resultant compressor discharge pressure increase). From this, savings were calculated for four model piping distributions for the four prototype compressor systems. To calculate both energy and piping costs, simplified, representative piping systems were assumed for each prototype.

4.1 Key Assumptions for Energy Savings Analysis

Key assumptions made for all modeled prototype systems include:

- System operating pressure of 100 psig (California Utilities Statewide Codes and Standards Team 2013).
- Baseline leak load of 20 percent capacity with final proposed load of 10 percent after leak testing and monitoring measures. Of the 10 percent reduction, two percent is attributed to testing at pipe installation and commissioning and 8 percent to ongoing monitoring and leak management over the life of the system. Twenty percent is on the high end of accepted normal leak loads in industrial settings. Ten percent load is on the low end of the accepted industrial target range; addressing leaks when the load exceeds 10 percent is often cited as where the effort becomes economical and prudent. See Section 3.2.4 through 3.2.6 for additional supporting information.
- Realization rate of 80% for leak repairs in response to monitoring data and alerts.
- Baseload compressor profile generally near 100 percent load with some variation during ramp-up and ramp-down hours while trim compressor load varies according to prototypes developed in 2013 code cycle (California Utilities Statewide Codes and Standards Team 2013).
- Primary receiver sized to two gal/cfm of trim load as designated by existing code requirements.
- Generic AirMaster+ compressors were selected from the AirMaster+ compressor catalog, representative of typical Title 24-compliant compressor operating curves.
- Trim compressors are equipped with VSDs, as required by existing code.
- System in use 5,600 hours per year (16 hours a day, 7 days a week, 50 weeks per year) (California Utilities Statewide Codes and Standards Team 2013).

Since piping designs vary from site to site, a generic piping distribution system assumption was necessary to calculate pressure drops and resultant savings associated with the pipe sizing measure. Key assumptions for the modeled piping distribution systems include:

- Sixty-seven percent utilization factor of end uses (i.e., peak coincident use is 2/3 of nominal sum of all end use rated cfm) (Compressed Air & Gas Institute n.d., Arfalk 2018, Compressed Air & Gas Institute 2016). This parameter is necessary to correlate compressor size to piping distribution size.
- A nominal compressed air consumption of five cfm per end use was used to calculate the number of end uses in the prototype piping system. Most small

handheld and actuator end uses will use about this much while larger machines may include many individual end uses (Compressed Air & Gas Institute 2016).

- Square building with 100 square feet of area per end use (used to determine piping lengths).
- Maximum pressure drop is to end use at furthest from the compressed air source.
- Looped distribution header with intermediate legs, representing best pipe design practice and is conservative from a pipe sizing cost and savings perspective. Loop legs spaced to ensure that no end use is greater than 30 feet from header. No secondary loops are included as is sometimes seen in designs. Savings should be even greater in those cases due to additional pipe lengths.

4.2 Energy Savings Methodology

4.2.1 Energy Savings Methodology per Prototypical Building

The Energy Commission directed the Statewide CASE Team to model the energy impacts using prototypical building models that represent typical market conditions. The Standard Design (baseline) and Proposed Design (measure) conditions are the same for both new construction and additions and alterations. The proposed measures and compressed air systems are unaffected by climate zone, generally. Although outside air conditions at compressor inlets can affect compressed air system efficiency somewhat, the effect is marginal and ducting from outside air is not industry standard practice. Since there are no other impacts from weather, no climate zone-specific modeling is required. The Statewide CASE Team found that variation between climate zone TDV effects was about one percent, justifying the use of average climate zone TDV factors when calculating energy and energy cost impacts.

Compressed air systems greater than 25 hp are typically used in industrial facilities which do not have CASE program prototypes and have drastically different conditions between sites. As such, the Statewide CASE Team had to rely on custom prototype buildings for the compressed air measures based on precedent and typical conditions as determined from research and stakeholder engagement. The Statewide CASE Team relied on the 2013 Final CASE Report which included four prototype compressed air systems. There is an existing Title 24, Part 6 requirement that covers the building system in question and applies to both new construction and alterations, so the Standard Design is minimally compliant with the 2019 Title 24 requirements. As such, the representative compressed air systems in Table 17 were modified to comply with existing Title 24, Part 6 requirements based on 2013 Final CASE Report.

Table 17: Representative Compressed Air Systems

	Prototype 1	Prototype 2	Prototype 3	Prototype 4
Rated Flow (cfm)	579	966	2,181	4,666
Nominal Operating Base Load (cfm)	342	729	1,417	3,138
Nominal Trim Load (cfm)	237	237	764	1,528
Primary Receiver Size (gall)	474	474	1,528	3,050
Compressor 1	75 hp, load/unload, single stage, lubricant injected, reciprocating	150 hp, load/unload, single stage, lubricant injected, reciprocating	300 hp, load/unload, single stage, lubricant injected, reciprocating	500 hp, inlet vane, multiple stage, centrifugal
Compressor 2	50 hp, VSD, single stage, lubricant injected, rotary screw	50 hp, VSD, single stage, lubricant injected, rotary screw	150 hp, VSD, single stage, lubricant injected, rotary screw	150 hp, VSD, single stage, lubricant injected, rotary screw
Compressor 3	N/A	N/A	N/A	150 hp, VSD, single stage, lubricant injected, rotary screw

Two load profiles were modeled for each system, a weekday profile and a weekend profile based on the 2013 Final CASE Report. The load profile shapes shown in Figure 4 and Figure 5 are the same for each prototype, scaled to match the capacity of each system. More detailed descriptions of these systems can be found above in Table 17, and Section 4.1 further details the interactions considered between these variables.

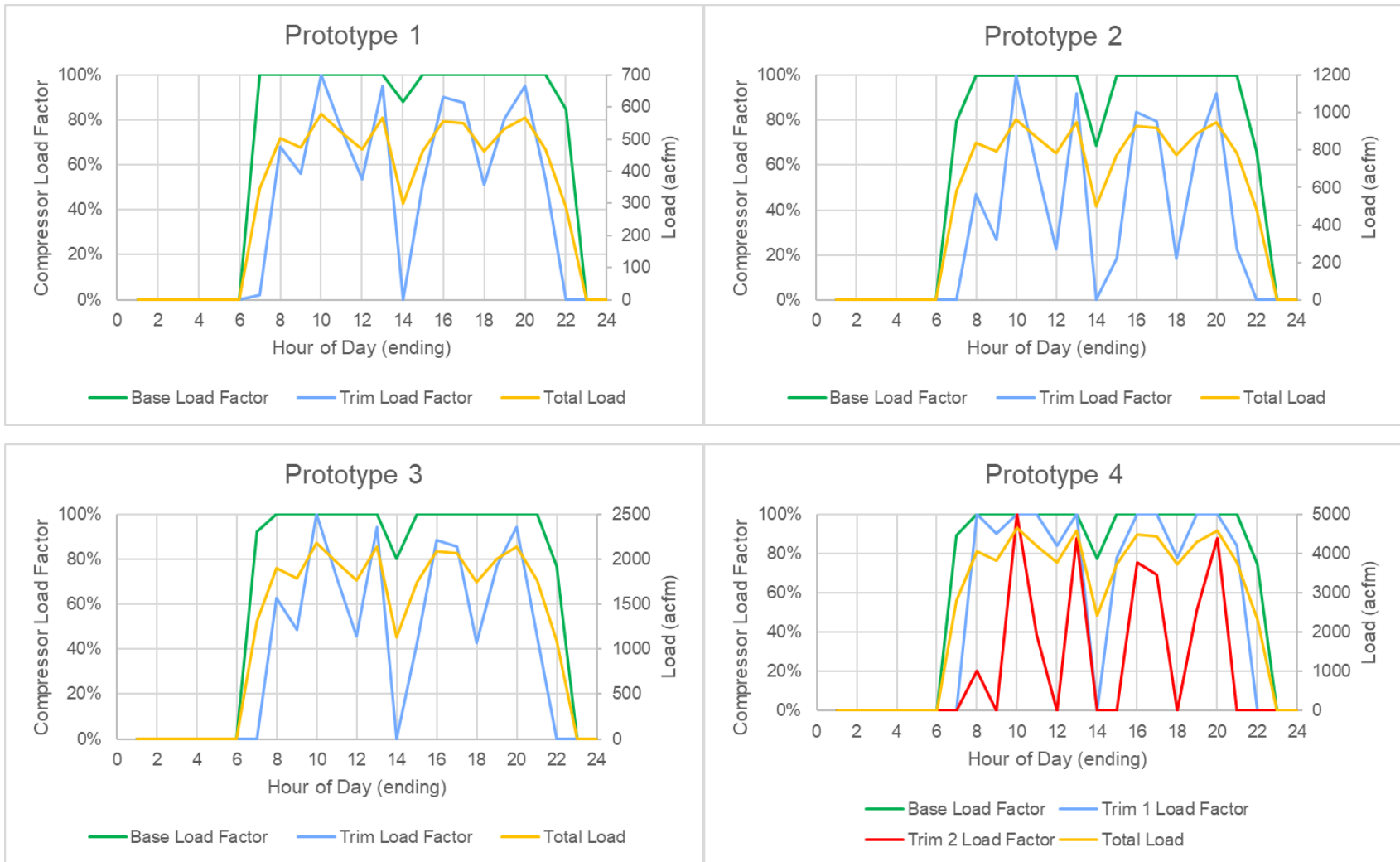

Figure 4: Prototype weekday load profiles.

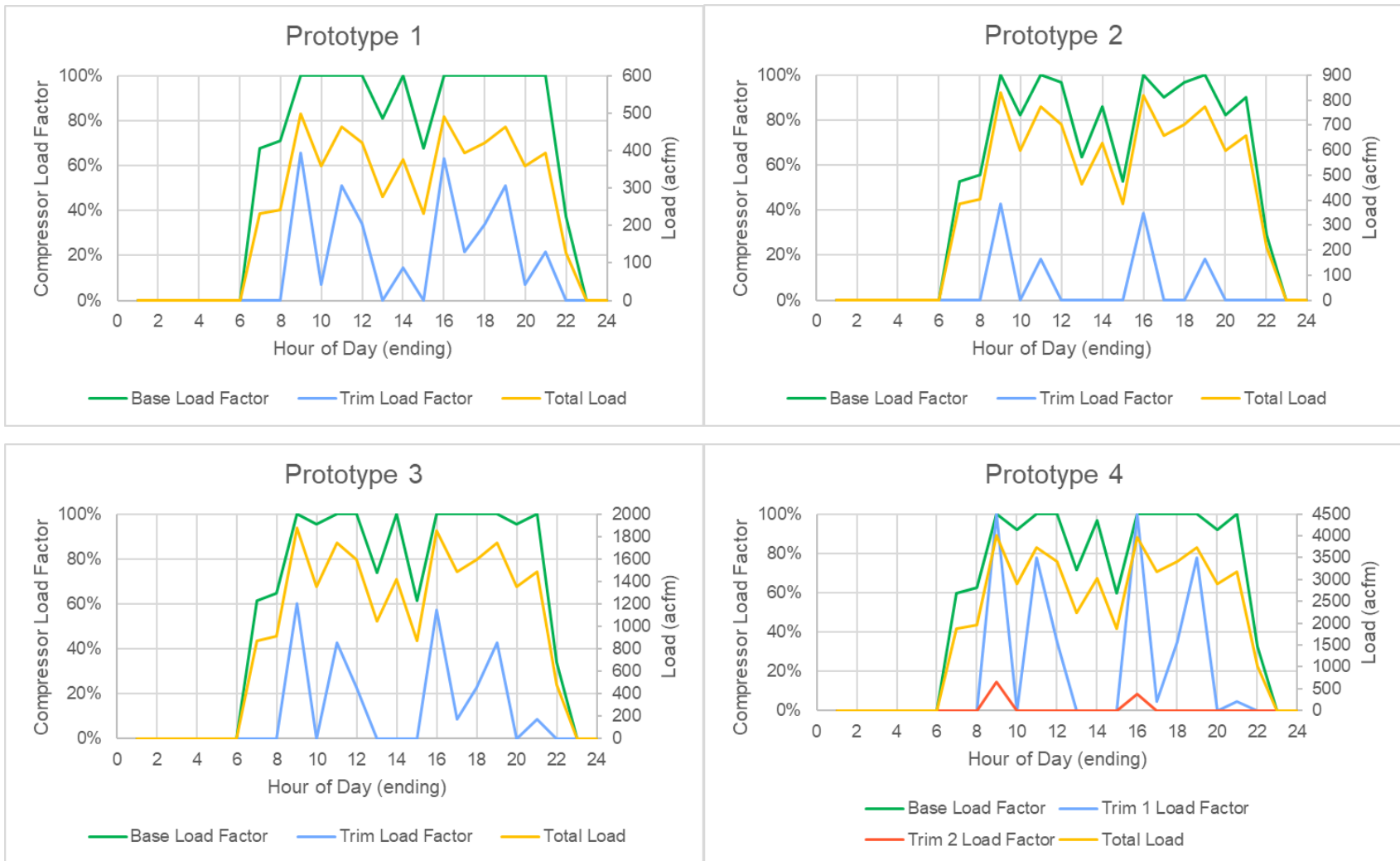

Figure 5: Prototype weekend load profiles.

The relationships between savings and leak load reduction from a baseline of 20 percent leaks are shown in Figure 6 as calculated by modeling each prototype across incremental leak load fractions. For instance, zero percent leak reduction corresponds to a 20 percent leak load (baseline) while two percent leak reduction corresponds to an 18 percent leak load, and so on. This incremental modeling was performed to establish a relationship between savings and leak reduction. Hourly energy usage and savings for weekday and weekend profiles were calculated to correlate to energy and cost savings on a TDV basis, as well.

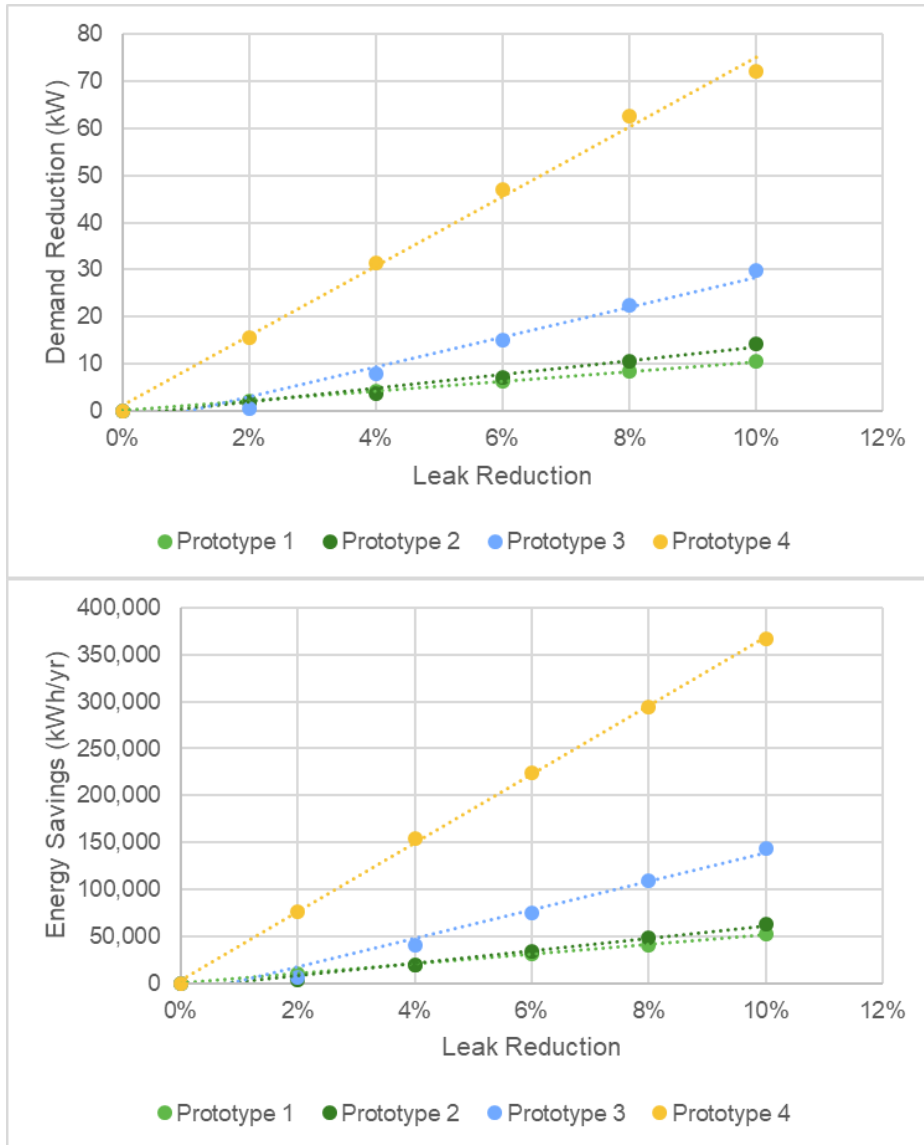

Figure 6: Energy and demand savings dependence on leak load reduction.

Using these relationships for each prototype system the savings for the leak testing and monitoring measures were calculated using the standard and proposed conditions listed in Table 18. As described in Section 2, these are relatively conservative baseline and

target leak load fractions. Gains in system efficiency due to tracking of specific efficiency (kW/100 cfm) are not modeled for several reasons. Namely, the source and corrective actions for this KPI are myriad and cannot reasonably be accounted for in this research, efficiency gains are unknown, and the existing code is already designed to improve system efficiency and was partially captured in the 2013 code cycle. Excluding this benefit contributes to a potentially conservative savings estimate.

The mechanism for compressed air leakage reductions during piping installation is that unless piping is checked for leaks, some fraction of piping connections will have leaks. It is significantly easier to fix piping leaks while the piping is being assembled than later. From discussions with stakeholders, a significant fraction of piping is inspected for leaks during installation as part of best practice installations. The proposed measure would ensure this best practice is followed by all installers.

The mechanism of energy savings for leak reductions associated with monitoring is that monitoring of changes in air flows during low or no-load periods are indicative of leakage and can help plant management track leakage rates. As a result, leakage tracking and repair can occur soon after significant leakage sources are added to the compressed air system. Monitoring is modeled after leak testing, successively stacking the measures.

Table 18: Leak Testing and Monitoring Standard Design and Proposed Design Conditions

Standard Design (Baseline)	Leak Testing Proposed Design (Measure Case)	Leak Monitoring Proposed Design (Measure Case)
20%	18%	10%

For the pipe sizing measure, it was necessary to develop a prototype piping system to correlate calculated pressure loss with piping material costs. The piping systems were developed for each prototype based on assumed end use and facility characteristics. It should be noted that piping systems are highly variable, depending on a site’s end uses, machinery, facility layout, and design options. Piping layouts may or may not incorporate a loop and various subordinate branches or loops from the main header, for instance. However, cost and benefits would both scale across various designs and B/C ratios greater than 1.0 are assured for any system designed to minimize pressure loss.

The piping system for Prototype 1 based on the key assumptions above is shown in Figure 7. End uses are arranged in a square with a looped distribution system supplying air to service line drops.

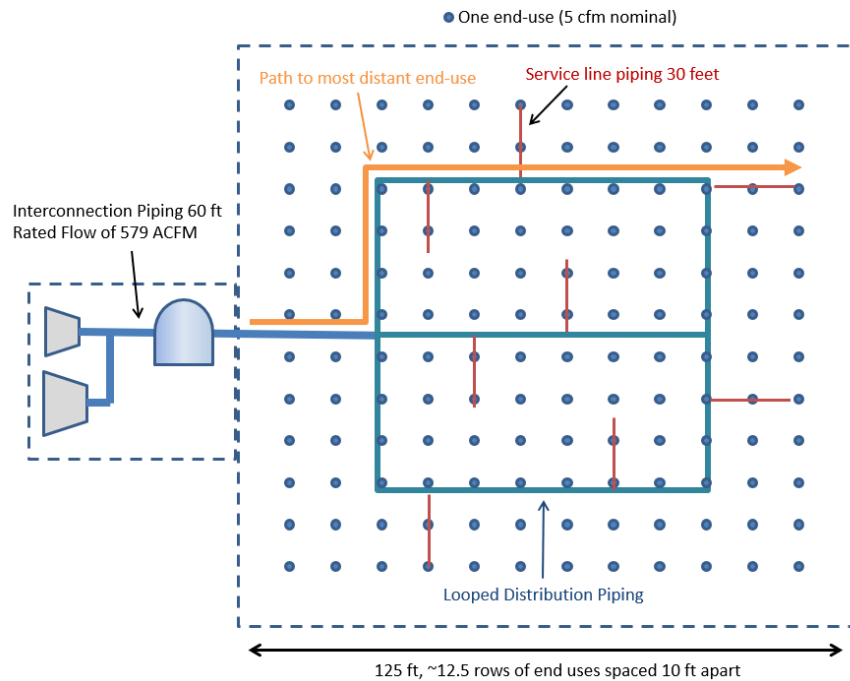
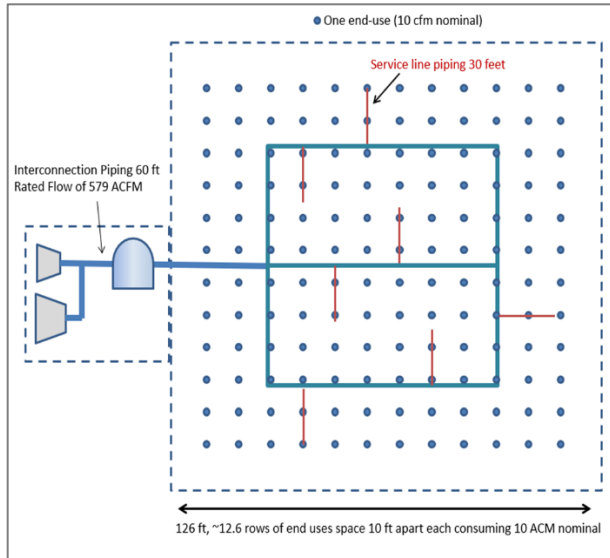

Figure 7: Piping layout of Prototype 1 showing path of greatest frictional pressure loss.

The frictional pressure loss includes calculation of pressure drops for three sections: the interconnection piping, the loop, and the service line. The loop pressure losses were calculated by summing the losses across the loop path, accounting for the reduced flow after each service line takeoff. The analysis assumes that the rated flow is split evenly between each branch of the loop since each would pass roughly an equal number of end uses.

Prototypes 2, 3, and 4 have similar layouts as seen in Figure 8, albeit with different flow rates along the path to the most-distant end use, depending on the system size and total number of end uses.



a) Prototype 1. Rated flow 579 cfm

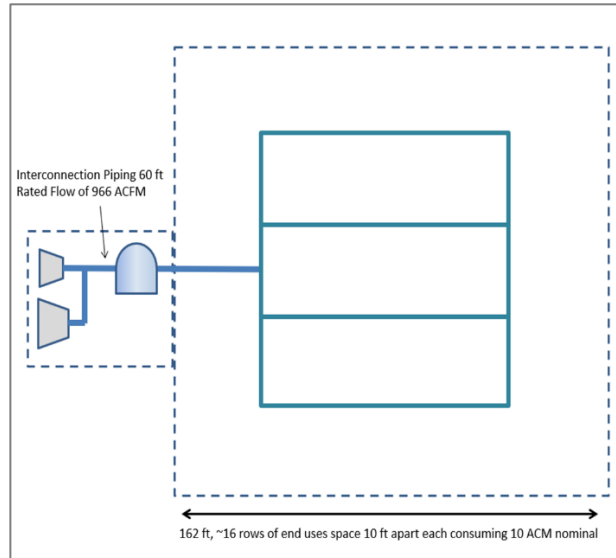

b) Prototype 2. Rated flow 966 cfm

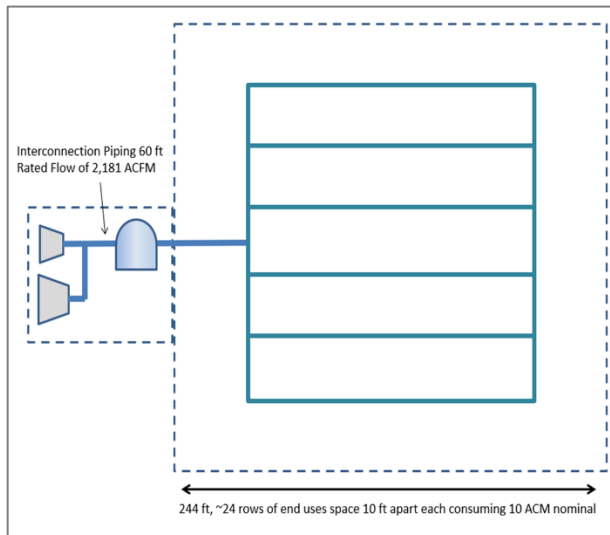

c) Prototype 3. Rated flow 2,181 cfm

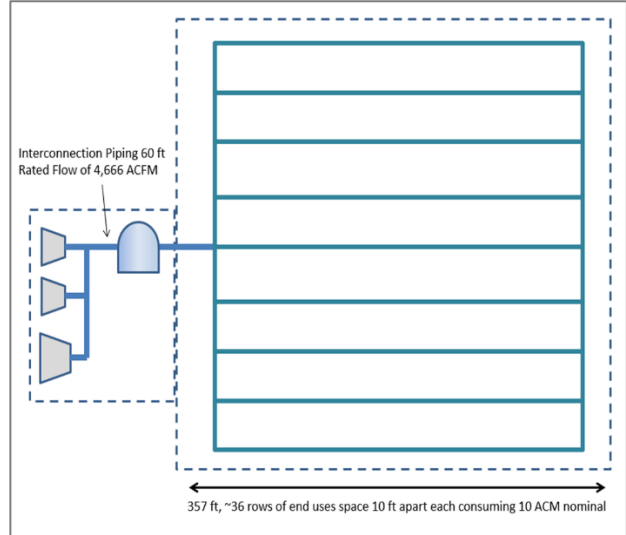

d) Prototype 4. Rated flow 4,666 cfm

Figure 8: Piping layouts, not to scale.

The piping layout prototype parameters common to both the Standard and Proposed Designs are listed in Table 19. The number of end uses for each prototype are based on the compressed air plant capacity and the average nominal end use load.

Table 19: Prototype Piping Systems

	Prototype 1	Prototype 2	Prototype 3	Prototype 4
Interconnection Piping Length (ft)	60			
Number of End Uses	156	260	586	1,254
Nominal End Use Load (cfm)	5			
Leak Load Fraction	10%			
End Use Coincidence Factor	67%			
Floor Area per End Use (ft ²)	100			
Service Line Length (ft)	30			

The prototype system was designed conservatively by assuming a single loop layout, minimal end use loads, and relatively short piping lengths. Any larger, more complex system will have high pressure drops (and thus greater savings), albeit balanced by increased measure cost. Additionally, baseline pipe sizes were specified to be incrementally smaller than right-sized piping, using standard pipe sizes. This assumption is conservative as well, both in terms of measure cost and energy benefits. Larger differences between the Standard and Proposed Design conditions would increase both cost and energy savings.

The Standard and Proposed Design conditions for the pipe sizing measure are shown in Table 20. The piping diameters for the Proposed Designs were selected from standard piping sizes such that the total pressure drop through the system is minimally compliant with the proposed code language.

Table 20: Conditions for Pressure Drop Calculations of Each Prototype System

Common System Inputs	Prototype 1	Prototype 2	Prototype 3	Prototype 4
Rated Flow (cfm)	579	966	2,181	4,666
Total hp	125	200	450	800
Nominal System Pressure (psig)	100	100	100	100
Compression Ratio	7.80	7.80	7.80	7.80
Interconnection Piping Length (ft)	60	60	60	60
Average Nominal End Use Load (cfm/load)	5	5	5	5
Peak Load Diversity	67%	67%	67%	67%
Coincident Peak Load per End Use	3.35	3.35	3.35	3.35
Leakage	10%	10%	10%	10%
Number of End Uses	156	260	586	1254
Floor Area per End Use (sq ft)	100	100	100	100
Building Size (sq ft)	15,555	25,952	58,594	125,355
Loop Length Multiplier (to account for four sides and intermediate legs)	5	6	8	11
Total Loop Piping Length (ft)	424	727	1,616	3,455
Peak Flow to Most Distant Wall (cfm)	62.4	80.5	121.0	177.0
Length to Most-Distant Wall (ft)	124.7	161.1	242.1	354.1
Production Area (square ft)	15,555	25,952	58,594	125,355
Number of Legs in Main Loop	3	4	6	9
Length per Leg in Main Loop (ft)	141	182	269	384
Entering Flow Rate per Loop Section (cfm)	193	242	364	518
Peak Flow at Furthest End Use (cfm)	21	20	20	20
Average Flow per Leg of Main Loop (cfm)	107	131	192	269
Service Line Piping Length (ft)	30.0	30.0	30.0	30.0
Total Service Line Piping Length (ft)	4,667	7,786	17,578	37,607

The following formula for smooth, non-pulsating pipe flow developed by E.G. Harris was used to calculate the pressure drop for each segment of piping in each prototype systems (Compressed Air & Gas Institute 2016).

$$f = \frac{0.1025 \times L \times q^2}{r \times d^{5.31}}$$

where:

- f = pressure drop, psi
- L = length of pipe, ft
- q = cubic feet of free air per second
- r = ratio of compression (from free air), dimensionless
- d = actual internal diameter of pipe, inches

Free air is the volume of ambient air at the compressor intake before compression.

Based on this empirically derived formula, Table 21 shows the pressure drop calculations for each prototype under the Standard Design Conditions. Pressure drops for each section of piping (interconnection, loop, and service line) are calculated separately and combined for the total frictional pressure loss.

It should be noted that Prototype 2 results in a total pressure loss that diverges somewhat from the relatively consistent results for the other three prototypes. This is because the selected prototype pipe sizes were limited to those typically available in piping product lines. For this reason, Prototype 2 has the same interconnection pipe diameter as Prototype 3 and the same loop pipe diameter as Prototype 1. Pipe diameters of 5 inches and 2.5 inches for the interconnection and loop piping, respectively, would have yielded pressure drops more consistent with the other prototypes. However, 5 inch pipe is atypical and 2.5 inch piping is not readily available in compressed air piping product lines, so the next best fit was selected. This imposed limitation based on typically marketed compressed air piping sizes results in a pressure drop that would otherwise appear anomalous or in error.

Similarly,

Table 22 shows the pressure drop calculations for each prototype under the Proposed Design Conditions. Note that for each of the Proposed Designs, the total pressure drop is less than the mandated pressure drop threshold of five percent (5 psi for a nominal 100 psi system) and was the minimally compliant Proposed Design using standard piping sizes.

Table 23 lists the saved difference between the Standard and Proposed Design conditions.

The calculations in

Table 24 segment the parallel sections or “legs” of loop piping into twenty equal sized sections which are assumed to be equally loaded with compressed air loads so that at the entrance the section all compressed air loads are served by this segment of pipe and each following segment has a reduction of air flow is reduced by five percent. A constant pipe diameter is used for the main distribution loop and each of the “legs”. Using a constant pipe diameter, the flow and pressure drop progressively decrease in each section as compressed air is delivered to loads served by each section of pipe.

Table 25 lists the air flow and pressure losses for each section of pipe between air drops in the prototype system, from the loop entry to the furthest end use.

Table 26 illustrates the velocity in each of the twenty sections of loop piping of constant diameter. The eleventh section is representative of the average velocity in the loop during coincident peak conditions. Only Prototype 4 would be compliant with the average loop velocity being less than 30 ft/sec but most of the remaining systems are close to the 30 ft/sec limit. However, each prototype has a pressure drop of less than five percent. This is to be expected since the 30 ft/s limit is typically more than sufficient to achieve pressure drop under five percent and is included in the proposal as simple design option in case calculating pressure across the system is not feasible or expedient for the designer.

Table 21: Standard Design Pressure Drop Calculations for Each Prototype System

Standard Design Inputs and Results (Baseline)	Prototype 1	Prototype 2	Prototype 3	Prototype 4
Interconnection Diameter (inch)	4	6	6	8
Velocity in Interconnection Piping (ft/sec)	111	82	185	223
Interconnection Pressure Loss (psig)	2.84	0.92	4.68	4.65
Loop Piping Diameter (inch)	2	2	3	4
Entering Loop Leg Velocity (ft/sec)	147	184	123	99
Most-Distant Loop Leg Velocity (ft/sec)	16	15	7	4
Loop Leg Average Velocity (ft/sec)	82	100	65	51
Loop Pressure Loss to Furthest Corner (psig)	10.57	21.28	8.31	5.22
Service Line Piping Diameter (inch)	0.75	0.75	0.75	0.75
Service Line Piping Velocity (ft/sec)	27	27	27	27
Service Line Pressure Drop (psig)	0.77	0.77	0.77	0.77
Total Pressure Loss (psig)	14.17	22.97	13.75	10.64

Table 22: Proposed Design Pressure Drop Calculations for Each Prototype System

Proposed Design Inputs and Results (Measure)	Prototype 1	Prototype 2	Prototype 3	Prototype 4
Interconnection Diameter (inch)	6	8	8	10
Velocity in Interconnection Piping (ft/sec)	49	46	104	143
Interconnection Pressure Loss (psig)	0.33	0.20	1.02	1.42
Loop Piping Diameter (inch)	3	3	4	6
Entering Loop Leg Velocity (ft/sec)	66	82	69	44
Most-Distant Loop Leg Velocity (ft/sec)	7	7	4	2
Loop Leg Average Velocity (ft/sec)	36	44	37	23
Loop Pressure Loss to Furthest Corner (psig)	1.2	2.5	1.8	0.6
Service Line Piping Diameter (inch)	1	1	1	1
Service Line Piping Velocity (ft/sec)	15	15	15	15
Service Line Pressure Drop (psig)	0.17	0.17	0.17	0.17
Total Pressure Loss (psig)	1.72	2.84	2.99	2.19

Table 23: Pressure Drop Reduction for Each Prototype System

Savings Summary	Prototype 1	Prototype 2	Prototype 3	Prototype 4
Reduced Pressure Loss (psig)	12.45	20.13	10.77	8.45

Table 24: Loop Piping Pressure Drop Inputs

	Prototype 1	Prototype 2	Prototype 3	Prototype 4
Length per loop leg	141	182	269	384
Flow (cfm/leg)	193	242	364	518
Flow per linear ft (cfm/ft)	0.73	0.75	0.74	0.74
Number of sections	20	20	20	20
Length/section (ft)	7.06	9.08	13.47	19.19
Reduction (cfm/section)	9.65	12.08	18.18	25.92
Proposed pipe diameter (inch)	3	3	4	6
Base pipe diameter (inch)	2	2	3	4

Table 25: Loop Piping Pressure Drop Calculation Using 20 Sections

Section Number	Prototype 1			Prototype 2			Prototype 3			Prototype 4		
	Flow free air (cf/s)	Proposed Pressure Drop (psi)	Base Pressure Drop (psi)	Flow free air (cf/s)	Proposed Pressure Drop (psi)	Base Pressure Drop (psi)	Flow free air (cf/s)	Proposed Pressure Drop (psi)	Base Pressure Drop (psi)	Flow free air (cf/s)	Proposed Pressure Drop (psi)	Base Pressure Drop (psi)
1	25	0.17	1.47	31	0.34	2.97	47	0.25	1.16	67	0.08	0.73
2	24	0.15	1.33	30	0.31	2.68	45	0.23	1.04	64	0.08	0.66
3	23	0.14	1.19	28	0.28	2.40	43	0.20	0.94	61	0.07	0.59
4	21	0.12	1.06	27	0.25	2.14	40	0.18	0.84	57	0.06	0.53
5	20	0.11	0.94	25	0.22	1.90	38	0.16	0.74	54	0.05	0.47
6	19	0.10	0.83	24	0.19	1.67	35	0.14	0.65	51	0.05	0.41
7	18	0.08	0.72	22	0.17	1.45	33	0.12	0.57	47	0.04	0.36
8	16	0.07	0.62	20	0.15	1.25	31	0.11	0.49	44	0.04	0.31
9	15	0.06	0.53	19	0.12	1.07	28	0.09	0.42	40	0.03	0.26
10	14	0.05	0.45	17	0.10	0.90	26	0.08	0.35	37	0.03	0.22
11	13	0.04	0.37	16	0.09	0.74	24	0.06	0.29	34	0.02	0.18
12	11	0.03	0.30	14	0.07	0.60	21	0.05	0.23	30	0.02	0.15
13	10	0.03	0.24	13	0.06	0.47	19	0.04	0.19	27	0.01	0.12
14	9	0.02	0.18	11	0.04	0.36	17	0.03	0.14	24	0.01	0.09
15	8	0.02	0.13	9	0.03	0.27	14	0.02	0.10	20	0.01	0.07
16	6	0.01	0.09	8	0.02	0.19	12	0.02	0.07	17	0.01	0.05
17	5	0.01	0.06	6	0.01	0.12	9	0.01	0.05	13	0.00	0.03
18	4	0.00	0.03	5	0.01	0.07	7	0.01	0.03	10	0.00	0.02
19	3	0.00	0.01	3	0.00	0.03	5	0.00	0.01	7	0.00	0.01
20	1	0.00	0.00	2	0.00	0.01	2	0.00	0.00	3	0.00	0.00
Total Drop		1.23	10.57	Total	2.47	21.28	Total	1.80	8.31	Total	0.61	5.22
		Reduced (psi)	9.34	Reduced (psi)	18.81	Reduced (psi)	6.50	Reduced (psi)	4.62			

Table 26: Velocity of Loop Piping at Actual Pressure (100 psig nominal)

Section Number	Prototype 1 Proposed Velocity (ft/s)	Prototype 1 Base Velocity (ft/s)	Prototype 2 Proposed Velocity (ft/s)	Prototype 2 Base Velocity (ft/s)	Prototype 3 Proposed Velocity (ft/s)	Prototype 3 Base Velocity (ft/s)	Prototype 4 Proposed Velocity (ft/s)	Prototype 4 Base Velocity (ft/s)
1	66	147	82	184	69	123	44	99
2	62	140	78	175	66	117	42	94
3	59	133	74	166	62	111	40	89
4	56	125	70	157	59	105	37	84
5	52	118	66	148	56	99	35	79
6	49	111	61	138	52	93	33	74
7	46	103	57	129	49	86	31	69
8	43	96	53	120	45	80	29	64
9	39	88	49	111	42	74	26	59
10	36	81	45	101	38	68	24	54
11	33	74	41	92	35	62	22	50
12	29	66	37	83	31	56	20	45
13	26	59	33	74	28	49	18	40
14	23	52	29	65	24	43	15	35
15	20	44	25	55	21	37	13	30
16	16	37	20	46	17	31	11	25
17	13	29	16	37	14	25	9	20
18	10	22	12	28	10	19	7	15
19	7	15	8	18	7	12	4	10
20	3	7	4	9	3	6	2	5

The energy and demand savings for properly sizing each prototype were calculated by combining the pressure drop differences between the Standard and Proposed Design conditions with the modeled relationships shown in Figure 9. Figure 9 shows the relationship between energy savings and the setpoint increase needed to achieve 100 psig operating pressure at the end uses. These linear relationships between pressure setpoint reduction and compressor energy were derived similarly to the leak-energy relationships in Figure 6. AirMaster+ modeling runs for each prototype across a range of pressure setpoints were used to calculation energy and demand for each point on the curves. Applying these curves to the pressure drop savings in Table 23 give the energy savings for each prototype.

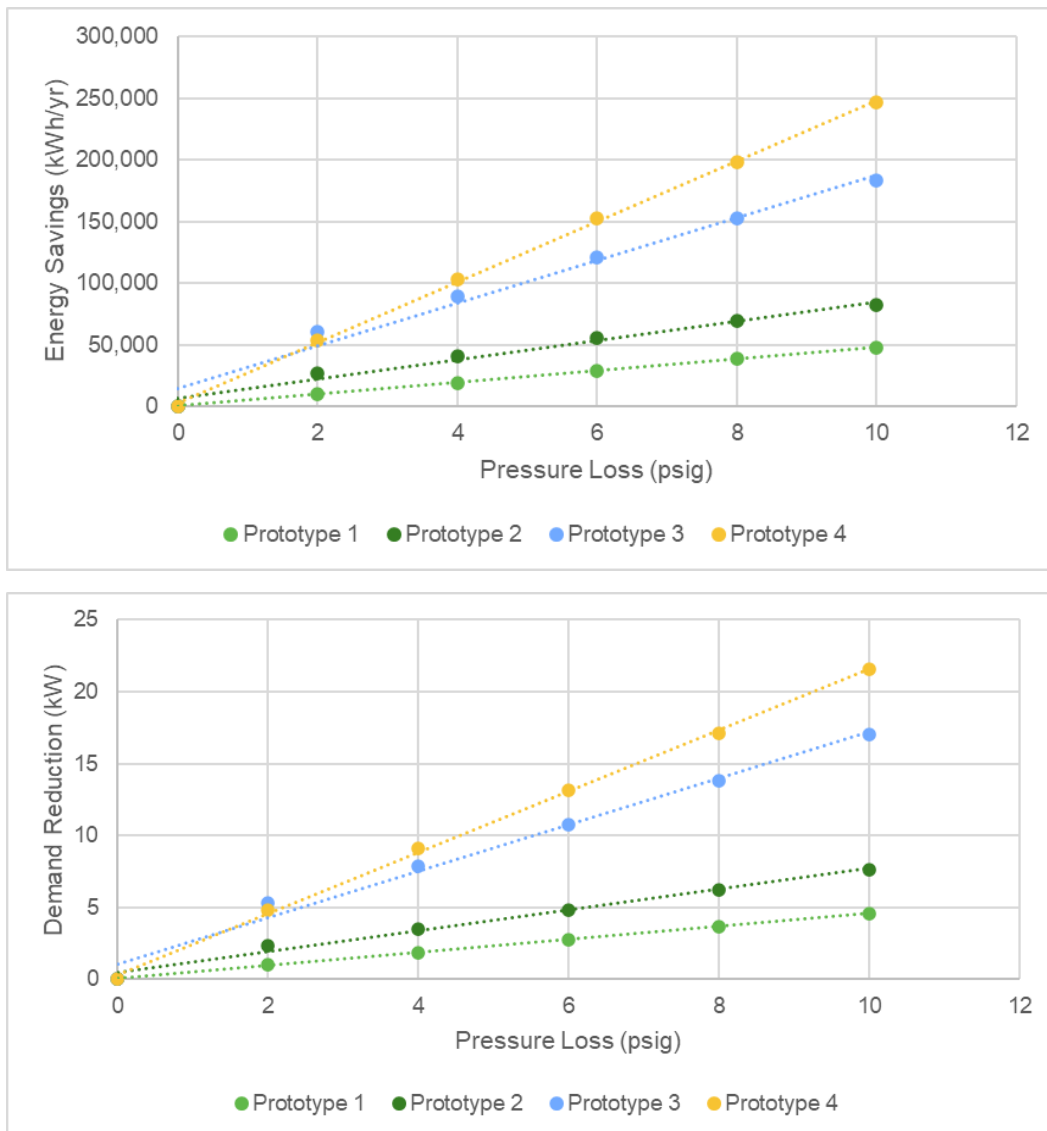

Figure 9: Energy and demand savings dependence on piping pressure loss.

4.2.2 Statewide Energy Savings Methodology

The per-unit energy impacts were extrapolated to statewide impacts using market survey and economic data to estimate the market size. This was necessary since manufacturing facilities and compressed air usage is not reflected in the statewide construction forecasts used in most CASE Reports. Appendix A presents additional information about the methodology and assumptions used to calculate statewide energy impacts.

4.2.3 Per-Unit Energy Impacts Results

Energy savings and peak demand reductions for each prototype are presented in Table 27: First-Year Energy Impacts Per Prototype System – Pipe , Table 28, and Table 29.

Energy savings and peak demand reductions for each prototype on a compressor hp basis are presented in Table 30, Table 31, and Table 32.

Table 27: First-Year Energy Impacts Per Prototype System – Pipe Sizing^a

Prototype	Electricity Savings (kWh/yr)	Peak Electricity Demand Reductions (kW)	Natural Gas Savings (therms/yr)	TDV Energy Savings (TDV kBtu/yr)
Prototype 1	59,150.5	5.68	N/A	1,662,648
Prototype 2	164,774.8	15.09	N/A	4,615,495
Prototype 3	201,556.6	18.47	N/A	5,660,805
Prototype 4	210,147.0	18.28	N/A	5,977,719

- a. “Prototype System” is used instead of the typical terminology “Prototype Building” since the covered process doesn’t have a typical Building Type and was rather defined as the Prototype Systems in Table 17. For all intents and purposes, they have equivalent meaning.

Table 28: First-Year Energy Impacts Per Prototype System – Leak Monitoring

Prototype	Electricity Savings (kWh/yr)	Peak Electricity Demand Reductions (kW)	Natural Gas Savings (therms/yr)	TDV Energy Savings (TDV kBtu/yr)
Prototype 1	42,058.5	4.55	N/A	1,177,764
Prototype 2	60,170.3	6.38	N/A	1,666,918
Prototype 3	137,378.9	14.25	N/A	3,844,830
Prototype 4	290,292.7	30.46	N/A	8,045,256

Table 29: First-Year Energy Impacts Per Prototype System – Leak Testing

Prototype	Electricity Savings (kWh/yr)	Peak Electricity Demand Reductions (kW)	Natural Gas Savings (therms/yr)	TDV Energy Savings (TDV kBtu/yr)
Prototype 1	10,168.8	1.11	N/A	279,025
Prototype 2	3,027.9	0.66	N/A	89,030
Prototype 3	6,548.2	1.58	N/A	178,391
Prototype 4	76,763.1	7.84	N/A	2,128,716

Table 30: First-Year Energy Impacts Per Compressor Horsepower – Pipe Sizing^a

Prototype	Electricity Savings (kWh/hp-yr)	Peak Electricity Demand Reductions (kW/hp)	Natural Gas Savings (therms/hp-yr)	TDV Energy Savings (TDV kBtu/hp-yr)
Prototype 1	473.2	0.05	N/A	13,301
Prototype 2	823.9	0.08	N/A	23,077
Prototype 3	447.9	0.04	N/A	12,580
Prototype 4	262.7	0.02	N/A	7,472

- a. Energy Impacts are shown per compressor horsepower instead of the typical per square foot. Horsepower is a more useful and understandable unit basis than square foot, which cannot reliably be extrapolated or representative of covered process and industrial market energy use.

Table 31: First-Year Energy Impacts Per Compressor Horsepower – Leak Monitoring

Prototype	Electricity Savings (kWh/hp-yr)	Peak Electricity Demand Reductions (kW/hp)	Natural Gas Savings (therms/hp-yr)	TDV Energy Savings (TDV kBtu/hp-yr)
Prototype 1	336.5	0.04	N/A	9,422
Prototype 2	300.9	0.03	N/A	8,335
Prototype 3	305.3	0.03	N/A	8,544
Prototype 4	362.9	0.04	N/A	10,057

Table 32: First-Year Energy Impacts Per Compressor Horsepower – Leak Testing

Prototype	Electricity Savings (kWh/hp-yr)	Peak Electricity Demand Reductions (kW/hp)	Natural Gas Savings (therms/hp-yr)	TDV Energy Savings (TDV kBtu/hp-yr)
Prototype 1	81.4	0.01	N/A	2,232
Prototype 2	15.1	0.003	N/A	445
Prototype 3	14.6	0.004	N/A	396
Prototype 4	96.0	0.01	N/A	2,661

5. Cost and Cost Effectiveness

5.1 Energy Cost Savings Methodology

Energy cost savings were calculated by applying the TDV energy cost factors to the energy savings estimates that were derived using the methodology described in Section 4.2. TDV is a normalized metric to calculate energy cost savings that accounts for the variable cost of electricity and natural gas for each hour of the year, along with how costs are expected to change over the period of analysis (30 years for residential measures and nonresidential envelope measures and 15 years for all other nonresidential measures). In this case, the period of analysis used is 15 years. The TDV cost impacts are presented in nominal dollars and in 2023 present value dollars and represent the energy cost savings realized over 15 years.

Monitoring measure costs are the same for new construction and additions/alterations since metering locations, equipment, and commissioning procedures are the same, regardless. Measure costs for pipe sizing and leak testing will depend on the length of piping being installed, whether new construction or additions/alterations. However, costs and benefits will scale proportionally with pipe length; therefore, the Statewide CASE Team concludes that the B/C ratios established for the prototype systems will be consistent across various application sizes.

5.2 Energy Cost Savings Results

Per-unit energy cost savings for newly constructed buildings and alterations that are realized over the 15-year period of analysis are presented in 2023 dollars in Table 33, Table 34, and Table 35. The TDV methodology allows peak electricity savings to be valued more than electricity savings during non-peak periods. When considering present value analysis over the 15-year period, energy costs savings escalate as energy rates increase but given the time value of money they are also discounted.

Table 33: 2023 PV TDV Energy Cost Savings Over 15-Year Period of Analysis – Pipe Sizing

Prototype	15-Year TDV Electricity Cost Savings (2023 PV \$)	15-Year TDV Natural Gas Cost Savings (2023 PV \$)	Total 15-Year TDV Energy Cost Savings (2023 PV \$)
Prototype 1	\$147,976	N/A	\$147,976
Prototype 2	\$410,779	N/A	\$410,779
Prototype 3	\$503,812	N/A	\$503,812
Prototype 4	\$532,017	N/A	\$532,017

Table 34: 2023 PV TDV Energy Cost Savings Over 15-Year Period of Analysis – Leak Monitoring

Prototype	15-Year TDV Electricity Cost Savings (2023 PV \$)	15-Year TDV Natural Gas Cost Savings (2023 PV \$)	Total 15-Year TDV Energy Cost Savings (2023 PV \$)
Prototype 1	\$104,821	N/A	\$104,821
Prototype 2	\$148,356	N/A	\$148,356
Prototype 3	\$342,190	N/A	\$342,190
Prototype 4	\$716,028	N/A	\$716,028

Table 35: 2023 PV TDV Energy Cost Savings Over 15-Year Period of Analysis – Leak Testing

Prototype	15-Year TDV Electricity Cost Savings (2023 PV \$)	15-Year TDV Natural Gas Cost Savings (2023 PV \$)	Total 15-Year TDV Energy Cost Savings (2023 PV \$)
Prototype 1	\$24,833	N/A	\$24,833
Prototype 2	\$7,924	N/A	\$7,924
Prototype 3	\$15,877	N/A	\$15,877
Prototype 4	\$189,456	N/A	\$189,456

5.3 Incremental First Cost

The Statewide CASE Team estimated the current incremental construction and post-adoption incremental costs using catalog costs, fully burdened California labor rates, and stakeholder feedback. Per Energy Commission direction, design costs are not included in the incremental first cost.

Stakeholders were interviewed to determine how best to estimate piping system costs. There is a variety of potential piping materials that any given system could use. While older systems typically relied on cast iron, most compressed air systems today opt for stainless steel, copper, aluminum, or plastics (ABS, Polyethylene, and HDPE). Each of

these has its advantages and disadvantages. Selection is usually driven by cost of materials and installation labor, process needs (e.g., food processing requiring stainless steel), and expertise of the installing party. According to stakeholders, aluminum piping is rapidly becoming the favored material due to the ease of installation and light weight properties. Extruded aluminum is marketed expressly for compressed air applications due to the ease of installation, smooth inner walls, light weight, and connecting fittings that don't require high-skilled labor. That said, stainless steel is still frequently used, although it is heavier, expensive, and may require welding if compression fittings are not available.

The first cost for the piping design measure here makes use of aluminum piping material costs gathered from online vendor listings as shown in Figure 10.

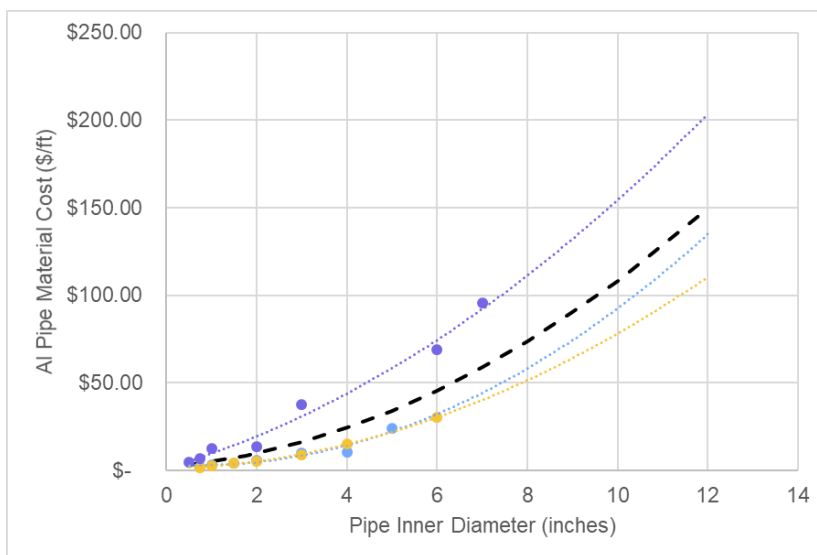

Figure 10: Aluminum piping costs per foot (black dashed line is average of identified costs).

Installation costs for aluminum piping were not available in found resources. Stakeholders have explained that aluminum piping installation does not necessarily require high-skilled labor as is often required for heavy, welded steel piping. However, since labor hours and costs for aluminum piping installation were elusive, the installation labor hours for welded 304 stainless steel piping with clevis hangers from RSMeans were used as a conservative estimate. These hours combined with the fully-burdened labor rates as established for Sections 3.3 and 3.4 were used to determine piping installation costs as seen in Figure 11.

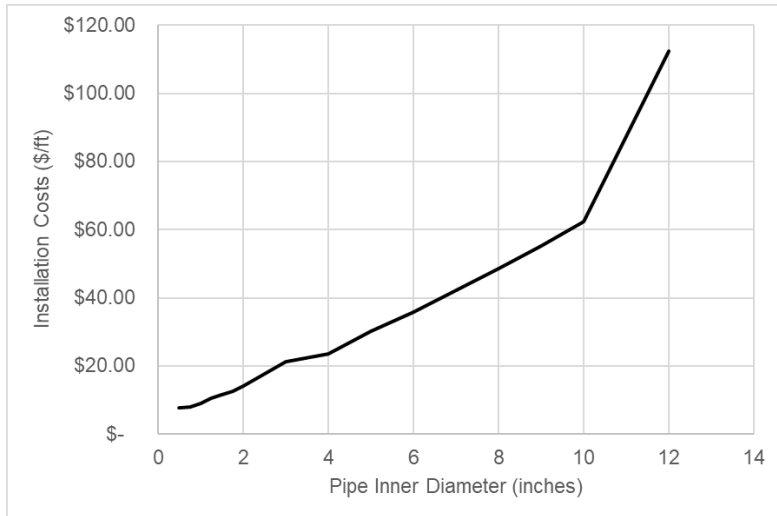

Figure 11: Piping installation costs.

The total incremental pipe sizing measure costs for each Prototype are shown in Table 36.

Table 36: Pipe Sizing Incremental Costs

Component	Prototype 1 Cost	Prototype 2 Cost	Prototype 3 Cost	Prototype 4 Cost
Interconnection Piping	\$1,275	\$1,677	\$1,677	\$2,078
Loop Piping	\$2,731	\$4,685	\$13,127	\$73,438
Service Line Piping	\$4,352	\$7,261	\$16,393	\$35,071
Labor	\$16,925	\$27,587	\$45,771	\$162,394
Total	\$25,284	\$41,210	\$76,968	\$272,982

The Statewide CASE Team interviewed stakeholders to gather costs for metering and monitoring products expressly designed for compressed air systems. Average costs for each component are listed in Table 37.

Table 37: Monitoring System Costs

Component	Cost
Flowmeter (<2 inch pipe)	\$617
Flowmeter (>2 inch pipe)	\$3,104
Power metering	\$1,250
Visual Display	\$4,000
Data Services Cost (\$/yr)	\$150 per compressor
Labor	8 hours per compressor

Note that including costs for the display and data services costs are conservative in that some systems will have central control systems that can be integrated with compressed air monitoring at lower cost.

The costs for leak testing are shown in Table 38. Note that some not all test procedures (e.g., flowmeter observation) would require all these components. Thus, the cost used for the leak testing measure is somewhat conservative, especially if metering is in place at the site. The labor for Prototype 1 is assumed to take one full day while the other three are scaled from that assumption based on total distribution loop piping length.

Table 38: Leak Testing Costs

Component	Prototype 1 Cost	Prototype 2 Cost	Prototype 3 Cost	Prototype 4 Cost
Pressure Gauge	\$171	\$171	\$171	\$171
Temperature Gauge	\$30	\$30	\$30	\$30
Leak Detecting Fluid	\$15	\$30	\$90	\$120
Test Labor (hours)	8	14	31	65

According to the methodology established for Sections 3.3 and 3.4, the relevant, fully burdened California labor rates are shown in Table 39. The electrician rate applies to monitoring installation labor while pipefitter rate applies to piping installation and testing.

Table 39: Labor Rates

Role	Fully Burdened Rate (\$/hr)
Electrician	\$107.12
Pipefitter	\$98.43

5.4 Incremental Maintenance and Replacement Costs

Incremental maintenance cost is the incremental cost of replacing the equipment or parts of the equipment, as well as periodic maintenance required to keep the equipment operating relative to current practices over the 15-year period of analysis. The present value of equipment maintenance costs (savings) was calculated using a three percent discount rate (d), which is consistent with the discount rate used when developing the 2022 TDV. The present value of maintenance costs that occurs in the nth year is calculated as follows:

$$\text{Present Value of Maintenance Cost} = \text{Maintenance Cost} \times \left[\frac{1}{1 + d} \right]^n$$

After the appropriate pipe size had been determined and installed, the results show there are no incremental maintenance and replacement cost associated with the pipe sizing measure. There are no expected maintenance or replacement costs for pressure pipe leak testing since the testing procedure only occurs during the construction phase.

For the leak testing and monitoring measures, the only maintenance required throughout the lifetime of the system was determined to be the calibration of the flow meters to maintain accuracy. However, stakeholders generally expressed that calibration is only crucial upon installation of the system. Metering manufacturers and system providers have explained that under normal conditions, maintenance and calibration costs is rarely necessary, especially when considering that alerts are more based on changes in outputs more than specific values. Despite this claim, flowmeter calibration costs on a \$500 per meter every five years were included as a conservative estimate.

Monitoring systems do require recurring data storage and management fees for systems that are based in the cloud. Although not all sites will require such data management services, including the costs is conservative in that it represents the highest-cost scenario. The data services costs are about \$150 per year per compressor according to stakeholders. Over the 15-year analysis period, this amounts to \$3,581.38 in 2023 present value dollars for a two-compressor system and \$5,372.07 for a three-compressor system.

Note that the monitoring system benefits derive largely from behavioral-dependent responses to the data and alerts. The measure savings are based on improved ongoing leak management and maintenance costs. The most conservative ongoing cost estimate would include going from no leak management protocols to a quarterly leak scan and repair. These ongoing leak maintenance costs assume quarterly labor of 6, 8, 10, and 12 hours for Prototypes 1, 2, 3, and 4, respectively.

5.5 Cost Effectiveness

This measure proposes a mandatory requirement. As such, a cost analysis is required to demonstrate that the measure is cost effective over the 15-year period of analysis.

The Energy Commission establishes the procedures for calculating cost effectiveness. The Statewide CASE Team collaborated with Energy Commission staff to confirm that the methodology in this report is consistent with their guidelines, including which costs were included in the analysis. The incremental first cost and incremental maintenance costs over the 15-year period of analysis were included. The TDV energy cost savings from electricity savings were also included in the evaluation.

Design costs were not included nor were the incremental costs of code compliance verification.

According to the Energy Commission's definitions, a measure is cost effective if the benefit-to-cost (B/C) ratio is greater than 1.0. The B/C ratio is calculated by dividing the cost benefits realized over 15 years by the total incremental costs, which includes

maintenance costs for 15 years. The B/C ratio was calculated using 2023 PV costs and cost savings.

Results of the per-unit cost-effectiveness analyses are presented in Table 40, Table 41, and Table 42.

Table 40: 15-Year Cost-Effectiveness Summary Per Prototype – Pipe Sizing

Measure	Benefits TDV Energy Cost Savings + Other PV Savings^a (2023 PV\$)	Costs Total Incremental PV Costs^b (2023 PV\$)	Benefit-to- Cost Ratio
Prototype 1	\$147,976	\$25,284	5.85
Prototype 2	\$410,779	\$41,210	9.97
Prototype 3	\$503,812	\$76,968	6.55
Prototype 4	\$532,017	\$272,982	1.95

Table 41: 15-Year Cost-Effectiveness Summary Per Prototype – Leak Monitoring

Measure	Benefits TDV Energy Cost Savings + Other PV Savings^a (2023 PV\$)	Costs Total Incremental PV Costs^b (2023 PV\$)	Benefit-to- Cost Ratio
Prototype 1	\$104,821	\$45,349	2.31
Prototype 2	\$148,356	\$54,749	2.71
Prototype 3	\$342,190	\$64,150	5.33
Prototype 4	\$716,028	\$78,572	9.11

- a. **Benefits: TDV Energy Cost Savings + Other PV Savings:** Benefits include TDV energy cost savings over the period of analysis (Energy + Environmental Economics 2020). Other savings are discounted at a real (nominal – inflation) three percent rate. Other PV savings include incremental first-cost savings if proposed first cost is less than current first cost. PV maintenance cost savings are included if PV of proposed maintenance costs is less than PV of current maintenance costs.
- b. **Costs: Total Incremental Present Valued Costs:** Costs include incremental equipment, replacement, and maintenance costs over the period of analysis. Costs are discounted at a real (inflation-adjusted) three percent rate. Costs include incremental first cost if proposed first cost is greater than current first cost. Costs include PV of maintenance incremental cost if PV of proposed maintenance costs is greater than PV of current maintenance costs. If incremental maintenance cost is negative, it is treated as a positive benefit. If there are no Total Incremental PV Costs, the Benefit-to-Cost ratio is infinite.

Table 42: 15-Year Cost-Effectiveness Summary Per Prototype – Leak Testing

Measure	Benefits TDV Energy Cost Savings + Other PV Savings^a (2023 PV\$)	Costs Total Incremental PV Costs^b (2023 PV\$)	Benefit-to- Cost Ratio
Prototype 1	\$24,833	\$1,003	24.75
Prototype 2	\$7,924	\$1,582	5.01
Prototype 3	\$15,877	\$3,296	4.82
Prototype 4	\$189,456	\$6,743	28.10

- a. **Benefits: TDV Energy Cost Savings + Other PV Savings:** Benefits include TDV energy cost savings over the period of analysis (Energy + Environmental Economics 2020). Other savings are discounted at a real (nominal – inflation) three percent rate. Other PV savings include incremental first-cost savings if proposed first cost is less than current first cost. PV maintenance cost savings are included if PV of proposed maintenance costs is less than PV of current maintenance costs.
- b. **Costs: Total Incremental Present Valued Costs:** Costs include incremental equipment, replacement, and maintenance costs over the period of analysis. Costs are discounted at a real (inflation-adjusted) three percent rate. Costs include incremental first cost if proposed first cost is greater than current first cost. Costs include PV of maintenance incremental cost if PV of proposed maintenance costs is greater than PV of current maintenance costs. If incremental maintenance cost is negative, it is treated as a positive benefit. If there are no Total Incremental PV Costs, the Benefit-to-Cost ratio is infinite.

6. First-Year Statewide Impacts

6.1 Statewide Energy and Energy Cost Savings

The Statewide CASE Team calculated the first-year statewide savings for new construction by multiplying the per-unit savings, which are presented in Section 4.2.3, by assumptions about the percentage of newly constructed buildings that would be impacted by the proposed code. The statewide new construction forecast for 2023 is presented in Appendix A as are the Statewide CASE Team’s assumptions about the percentage of new construction that would be impacted by the proposal.

Additions and alteration impacts from the leak testing and monitoring measure are determined by assuming a 20 year measure life of compressors. Since the measure is triggered whenever a compressor needs to be replaced or added to an existing system, the assumption of 20 years combined with the existing market size can be used to estimate annual number of existing compressed air systems that would be triggered for an addition or alteration code requirement.

The first-year energy impacts represent the first-year annual savings from all buildings that were completed in 2023. The 15-year energy cost savings represent the energy cost savings over the entire 15-year analysis period. The statewide savings estimates do not take naturally occurring market adoption or compliance rates into account.

Table 43, Table 44, and Table 45 present the first-year statewide energy and energy cost savings from newly constructed buildings by climate zone.

Table 43: Statewide Energy and Energy Cost Impacts – Pipe Sizing

	First-Year Electricity Savings (GWh)	First-Year Peak Electrical Demand Reduction (MW)	First -Year Natural Gas Savings (MMtherms)	15-Year Present Valued Energy Cost Savings (PV\$ million in 2023)
Total ^a	13.6	1.25	N/A	34.0

- a. It is assumed that the size of the alterations market is relatively small. Statewide impacts only include estimates from new construction. As a result, the reported statewide savings are lower than what will be realized because the proposed requirements will apply to alterations.

Table 44: Statewide Energy and Energy Cost Impacts – Leak Monitoring

Construction Type	First-Year Electricity Savings (GWh)	First-Year Peak Electrical Demand Reduction (MW)	First -Year Natural Gas Savings (MMTherms)	15-Year Present Valued Energy Cost Savings (PV\$ million in 2023)
New Construction	9.0	0.95	N/A	22.3
Additions and Alterations	20.3	2.15	N/A	50.3
Total	29.3	3.11	N/A	72.6

a. First-year savings from all alterations completed statewide in 2023.

Table 45: Statewide Energy and Energy Cost Impacts – Leak Testing

	First-Year Electricity Savings (GWh)	First-Year Peak Electrical Demand Reduction (MW)	First -Year Natural Gas Savings (MMTherms)	15-Year Present Valued Energy Cost Savings (PV\$ million in 2023)
Total ^a	1.4	0.19	N/A	3.5

a. It is assumed that the size of the alterations market is relatively small. Statewide impacts only include estimates from new construction. As a result, the reported statewide savings are lower than what will be realized because the proposed requirements will apply to alterations.

6.2 Statewide Greenhouse Gas (GHG) Emissions Reductions

The Statewide CASE Team calculated avoided GHG emissions assuming the emissions factors specified in the United States Environmental Protection Agency (U.S. EPA) Emissions & Generation Resource Integrated Database (eGRID) for the Western Electricity Coordination Council California (WECC CAMX) subregion. Avoided GHG emissions from natural gas savings attributable to sources other than utility-scale electrical power generation are calculated using emissions factors specified in U.S. EPA’s Compilation of Air Pollutant Emissions Factors (AP-42). See Appendix C for additional details on the methodology used to calculate GHG emissions. In short, this analysis assumes an average electricity emission factor of 240.4 metric tons CO₂e per GWh based on the average emission factors for the CACX EGRID subregion.

Table 46 presents the estimated first-year avoided GHG emissions of the proposed code change. During the first year, GHG emissions of 12,297 metric tons of carbon dioxide equivalents (MTCO₂e) would be avoided.

Table 46: First-Year Statewide GHG Emissions Impacts

Measure	Electricity Savings^a (GWh/yr)	Reduced GHG Emissions from Electricity Savings^a (Metric Tons CO₂e)	Natural Gas Savings^a (MMTherms/yr)	Reduced GHG Emissions from Natural Gas Savings^a (Metric Tons CO₂e)	Total Reduced CO₂e Emissions^{a,b} (Metric Tons CO₂e)
Pipe Sizing	13.6	3,275	N/A	N/A	3,275
Leak Monitoring	29.3	7,049	N/A	N/A	7,049
Leak Testing	1.4	339	N/A	N/A	339
Total	44.4	10,663	N/A	N/A	10,663

a. First-year savings from all buildings completed statewide in 2023.

b. Assumes the following emission factors: 240.36 MTCO₂e/GWh and 5,454.42 MTCO₂e/MMTherms.

6.3 Statewide Water Use Impacts

The proposed code change would not result in water savings.

6.4 Statewide Material Impacts

Stakeholder input was solicited for common compressed air piping material utilized in the industry. Per stakeholder feedback, cast iron steel pipes are used in older systems and copper, aluminum, or stainless-steel piping are used in new systems. As a result, increase of copper, aluminum, or steel piping use in compressed air systems is expected.

Meanwhile, there are no expected substantial impacts on material use for energy and air demand monitoring and pressure testing measures. Metering equipment is generally small and comprises sensors and wiring whose material impacts are too complicated and small to quantify.

Table 47: First-Year Statewide Impacts on Material Use

Material	Impact (I, D, or NC) ^a	Impact on Material Use (pounds/year)	
		Per-System Impacts	First-Year ^b Statewide Impacts
Steel	I	130	12,800
Aluminum	I	1,200	117,800

a. Material Increase (I), Decrease (D), or No Change (NC) compared to base case (lbs/yr).

b. First-year savings from all buildings completed statewide in 2023.

6.5 Other Non-Energy Impacts

The main non-energy benefit for the proposed compressed air energy and air demand monitoring measure is the increased awareness for the facility energy manager or plant operators. The insights afforded by monitoring can help avoid system failures and yield valuable information on plant operation. Compressed air monitoring data can often serve as a proxy representation of production facility health and output. Additionally, proper pipe sizing can help avoid pressure swings that can adversely impact production capabilities.

Other non-energy impacts include:

- Reduces noise. Compressed air leaks generate noise. Removing leaks from permanently installed header piping and from identifying piping leaks that are captured by ongoing monitoring would result in a quieter production plant.
- Preventative maintenance. Monitoring of compressed air production efficiency can help identify when air compressors need repair or are nearing their end of life. This can enhance the reliability of the compressed air system.
- System monitoring can also identify other equipment problems or scheduling problems. Monitoring can assist in identifying if components such as air solenoids have failed or if the primary compressed air system is not being turned off at the end of the shift.
- Lower equipment cost. Compressed air systems that have excessive leaks or need to operate at excessively high pressures due to pressure drop in compared air piping may require more equipment capacity. Fixing these problems in some cases can eliminate the need for purchasing more air compressors to increase capacity.

7. Proposed Revisions to Code Language

7.1 Guide to Markup Language

The proposed changes to the standards, Reference Appendices, and the ACM Reference Manuals are provided below. Changes to the 2019 documents are marked with red underlining (new language) and ~~strikethroughs~~ (deletions).

7.2 Standards

Section 120.6 – Mandatory Requirements for Covered Processes

120.6(e) Mandatory Requirements for Compressed Air Systems. All new compressed air systems, and all additions or alterations of compressed air systems where the total combined ~~online~~ horsepower (hp) of the compressor(s) is 25 horsepower or more shall meet the requirements of Subsections 1 through ~~35~~. These requirements apply to the compressors, pipng system, and related controls that provide compressed air and do not apply to any equipment or controls that use or process the compressed air.

~~EXCEPTION 1 to Section 120.6(e): Alterations of existing compressed air systems that include one or more centrifugal compressors.~~

~~EXCEPTION 12 to Section 120.6(e): Compressed Air Systems, including medical gas, serving healthcare facilities. Medical gas compressed air systems in healthcare facilities.~~

1. **Trim Compressor and Storage.** The compressed air system shall be equipped with an appropriately sized trim compressor and primary storage to provide acceptable performance across the range of the system and to avoid control gaps. The compressed air system shall comply with Subsection A or B below:
 - A. The compressed air system shall include one or more variable speed drive (VSD) compressors. For systems with more than one compressor, the total combined capacity of the VSD compressor(s) acting as trim compressors must be at least 1.25 times the largest net capacity increment between combinations of compressors. The compressed air system shall include primary storage of at least one gallon per actual cubic feet per minute (acfm) of the largest trim compressor; or,
 - B. The compressed air system shall include a compressor or set of compressors with total effective trim capacity at least the size of the largest net capacity increment between combinations of compressors, or the size of the smallest compressor, whichever is larger. The total effective trim capacity of single compressor systems shall cover at least the range from 70 percent to 100 percent of rated capacity. The effective trim capacity of a compressor is the size of the continuous operational range where the specific power of the compressor (kW/100 acfm) is within 15 percent of the specific power at its most efficient operating point. The total effective trim capacity of the system is the sum of the effective trim capacity of the trim

compressors. The system shall include primary storage of at least 2 gallons per acfm of the largest trim compressor.

EXCEPTION 1 to Section 120.6(e)1: ~~Compressed air systems in existing facilities that are adding or replacing less than 50 percent of the online capacity of the system~~
Alterations where the total combined added or replaced compressor horsepower is less than the average per-compressor horsepower of all compressors in the system.

EXCEPTION 2 to Section 120.6(e)1: Alterations where all added or replaced compressors are variable speed drive (VSD) compressors and at least one gallon of storage is added per actual cubic feet per minute (acfm) of added compressor capacity.

EXCEPTION 3 to Section 120.6(e)1: Compressed air systems that have been approved by the Energy Commission Executive Director as having demonstrated that the system serves loads for which typical air demand fluctuates less than 10 percent.

EXCEPTION 4 to Section 120.6(e)1: Alterations of existing compressed air systems that include one or more centrifugal compressors.

2. **Controls.** Compressed air systems with three or more ~~than one~~ compressors online, ~~having and~~ a combined horsepower rating of more than 100 hp; ~~must shall~~ operate with ~~a controller that is~~ controls that are able to choose the most energy efficient combination and loading of compressors within the system based on the current compressed air demand ~~as measured by a sensor.~~
3. **Monitoring.** Compressed air systems having a combined horsepower rating equal to or greater than 100 hp shall have an energy and air demand monitoring system with the following minimum requirements:
 - A. Measurement of system pressure.
 - B. Measurement of amps or power of each compressor.
 - C. Measurement or determination of airflow in cfm of each compressor at the same measurement interval.
 - D. Data logging of pressure, power in kW, airflow in cfm, and compressed air system specific efficiency in kW/100 cfm at intervals of 5 minutes or less.
 - E. Maintained data storage of at least the most recent 24 months.
 - F. Visual trending display of each recorded point, load, and specific efficiency.
4. **Leak Testing of Compressed Air Piping.** Compressed air system piping greater than 50 adjoining feet in length shall be pressure tested after being isolated from the compressed air supply and end uses. The piping shall be pressurized to the design pressure and test pressures shall be held for a length of time at the discretion of the Authority Having Jurisdiction, but in no case for less than 30 minutes, with no perceptible drop in pressure.

Necessary apparatus for conducting tests shall be furnished by the permit holder. If dial gauges are used for conducting this test, for pressure tests less than or equal to 100 psi (689 kPa) gauges shall be incremented in units of 1 psi (7 kPa) less, for pressure tests greater than 100 psi (689 kPa) gauges shall be incremented in units less than 2 percent of the test pressure. Test gauges shall have a pressure range not exceeding twice the test pressure.

Piping less than or equal to 50 adjoining feet in length shall be pressurized and inspected. Connections shall be tested with a noncorrosive leak-detecting fluid or other leak-detecting methods at the discretion of the Authority Having Jurisdiction.

5. **Pipe Sizing.** Compressed air piping greater than 50 adjoining feet in length shall be designed and installed to minimize frictional losses in the distribution network. These piping installations shall meet the requirements of Subsection A and either Subsection B or C below:
 - A. Service line piping shall have inner diameters greater than or equal to $\frac{3}{4}$ inch. Service line piping are pipes that deliver compressed air from distribution piping to end uses.
 - B. Piping section average velocity. Compressor room interconnection and main header piping shall be sized so that at coincident peak flow conditions, the average velocity in the segment of pipe is no greater than 20 ft/sec. Compressor room interconnection piping, and header piping is defined as the pipes that deliver compressed air from the compressor outlets to the inlet to the distribution piping. Each segment of distribution and service piping shall be sized so that at coincident peak flow conditions, the average velocity in the segment of pipe is no greater than 30 ft/sec. Distribution piping are pipes that deliver compressed air from the compressor room interconnection piping or main header piping to the service line piping.
 - C. Piping total pressure drop. Piping shall be designed such that piping frictional pressure loss at coincident peak loads are less than 5 percent of operating pressure between the compressor and end use or end use regulator.

36. **Compressed Air System Acceptance.** Before an occupancy permit is granted for a compressed air system subject to Section 120.6(e), the following equipment and systems shall be certified as meeting the Acceptance Requirements for Code Compliance, as specified by the Reference Nonresidential Appendix NA7. A Certificate of Acceptance shall be submitted to the enforcement agency that certifies that the equipment and systems meet the acceptance requirements specified in NA 7.13.

7.3 Reference Appendices

NA7.13 Compressed Air System Acceptance Tests

NA7.13.1 Compressed Air Control System

Acceptance tests for compressed air controls in accordance with Section 120.6(e)2.

NA7.13.1.1 Construction Inspection

~~Prior to functional testing, a compressed air system must verify~~ Verify and document the following prior to functional testing:

- (a) Size (hp), rated capacity (cfm), and control type of each air compressor.
- (b) Total ~~online~~ system capacity (the sum of the individual capacities).
- (c) System operating pressure.
- (d) Compressor(s) designated as trim compressors.
- (e) Method for observing and recording the states of each compressor in the system, which shall include at least the following states:
 - Off
 - Unloaded
 - Partially loaded
 - Fully loaded
 - Short/ cycling (loading and unloading more often than once per minute)
 - Blow off (venting compressed air at the compressor itself)

NA7.13.1.2 Functional Testing

Step 1: As specified by the test methods outlined in the Construction Inspection, verify that these methods have been employed, so that the states of the compressors and the current air demand (as measured by a flow sensor or otherwise inferred by system measurements) can be observed and recorded during testing.

Step 2: Run the compressed air supply system steadily at as close to the expected operational load range as can be practically implemented, for a duration of at least 10 minutes.

Step 3: Observe and record the states of each compressor and the current air demand during the test.

Step 4: Confirm that the combinations of compressors states meet the following criteria:

- (a) No compressor exhibits short-cycling (loading and unloading more often than once per minute).
- (b) No compressor exhibits blowoff (venting compressed air at the compressor itself).

- (c) For new systems, the trim compressors shall be the only compressors partially loaded, while the base compressors will either be fully loaded or off by the end of the test.

NA7.13.2 Compressed Air Monitoring

Acceptance tests for compressed air monitoring installed in accordance with Section 120.6(e)3.

NA7.13.2.1 Construction Inspection

Verify and document:

Monitoring system has the following capabilities:

- (a) Measurement of header or compressor discharge pressure.
- (b) Measurement of amps or power of each compressor.
- (c) Measurement or determination of airflow in cfm.
- (d) Data logging of pressure, power, airflow, and calculated compressed air system specific efficiency in kW/100 cfm at intervals of 5 minute or less.
- (e) Maintained data storage of at least the most recent 24 months.
- (f) Visual trending display of each recorded point, load, and specific efficiency.

NA7.13.2.1 Functional Testing

Verify and document the following:

- a) Data observed during test is being recorded to a log file that can be opened and viewed to see trend of airflow, power, and specific efficiency in at least 5 minute intervals.
- b) Airflow and compressor power data vary with loading and unloading of the compressor within typical performance expectations. Measurements should be observed across various loading, whether manually varied or in response to actual operational loads.

7.4 ACM Reference Manual

There are no proposed changes to the Nonresidential ACM Reference Manual.

7.5 Compliance Manuals

Chapter 10, Section 8 of the Nonresidential Compliance Manual will need to be revised. Additional clarifying examples of covered situations for the new proposed sections would be included. Furthermore, the existing examples will be modified to match the clean-up efforts for existing language, if necessary.

An example of piping sizing methodology would be included in the compliance manual. Pipe sizing tables may also be included but would add substantial length to the manual given the size and quantity of tables that would be required. Given that pipe sizing

tables and guidelines are readily available in free industry handbooks, it may be advantageous to exclude specific sizing tables from the code. The pipe sizing example with show how peak loads can be calculated for any given section of pipe in a distribution system and what the minimum pipe diameter should be at that location.

Much of the focus of the manual would be sample problems that help identify what requirements are triggered by various sizes of compressed air new installations and compressed air alterations.

A diagram or schematic of a typical compressed air system in the reference manual would be labeled with the pipe sections listed in Section 120.6(e)5. Interconnection, header, and service lines would all be identified. There is some ambiguity and flexibility with these terms in the compressed air industry since these terms are not strictly standardized. A diagram would help avoid any ambiguity with regards to the implementation and compliance of the proposed requirements.

In the support of the leak and pressure test requirement, leak testing procedures would be outlined in the Compliance Manual. These include:

- Isolating and pressurizing any piping longer than 50 feet which is newly added. A pressure gauge is installed on the pipe and if any noticeable drop in pressure in 30 minutes, use noncorrosive leak-detecting fluid or other leak-detecting methods to find leaks, fix the leaks and retest.
- For new piping less than 50 feet or replacement pipe, a description of how to use noncorrosive leak-detecting fluid or other leak-detecting methods to find leaks.

7.6 Compliance Documents

The proposed code change would modify some compliance documentation and may require some new forms. Additional discussion with compliance experts is needed during rulemaking to determine exactly what is necessary. At a minimum, some existing forms, namely NRCA-PRC-01-F and NRCI-PRC-01-E would need revisions to accommodate the new plans review and compliance checks.

8. Bibliography

- n.d. http://bees.archenergy.com/Documents/Software/CBECC-Com_2016.3.0_SP1_Prototypes.zip.
- Amon, Ricardo, Frank Moskowitz, and Donald Kazama. 2013. *California's Food Industry, Compressed Air Challenge*. California Energy Commission.
- Arfalk, Erik. 2018. *How to Calculate Your Compressor System's Working Pressure*. March 8. Accessed 2020. <https://www.thecompressedairblog.com/how-to-calculate-your-compressor-systems-working-pressure>.
- Association, National Energy Assistance Directors. 2011. "2011 National Energy Assistance Survey Final Report." Accessed February 2, 2017. <http://www.appriseinc.org/reports/Final%20NEADA%202011%20Report.pdf>.
- Atlas Copco. 2015. *Atlas Copco Compressed Air Manual*.
- Blum, Brian. 2015. *Plant Engineering, Compressed air efficiency at a distance*. <https://www.plantengineering.com/articles/compressed-air-efficiency-at-a-distance/>.
- Bonfa, Francesca, Miriam Bendetti, Stefano Ubertini, Vito Introna, and Annalisa Santolamazza. 2018. "New efficiency opportunities arising from intelligent real time control tools applications: the case of compressed air systems' energy efficiency in production and use." *International Conference on Applied Energy*. Energy Procedia.
- British Compressed Air Society. 2016. "Pressure and Leak Testing of Compressed Air Systems."
- BW Research Partnership. 2016. *Advanced Energy Jobs in California: Results of the 2016 California Advanced Energy*. Advanced Energy Economy Institute.
- California Air Resources Board. 2019. "Global Warming Potentials." <https://www.arb.ca.gov/cc/inventory/background/gwp.htm#transition>.
- California Department of Water Resources. 2016. "California Counties by Hydrologic Regions." Accessed April 3, 2016. <http://www.water.ca.gov/landwateruse/images/maps/California-County.pdf>.
- California Energy Commission. 2015. *2016 Building Energy Efficiency Standards: Frequently Asked Questions*. http://www.energy.ca.gov/title24/2016standards/rulemaking/documents/2016_Building_Energy_Efficiency_Standards_FAQ.pdf.
- . 2020. *2020 Workshops and Meetings*. <https://ww2.energy.ca.gov/title24/2022standards/prerulemaking/documents/>.

- . 2020. *2020 Workshops and Meetings*.
<https://ww2.energy.ca.gov/title24/2022standards/prerulemaking/documents/>.
 - . 2022. "Energy Code Data for Measure Proposals." *energy.ca.gov*.
https://www.energy.ca.gov/title24/documents/2022_Energy_Code_Data_for_Measure_Proposals.xlsx.
 - . 2019. "Housing and Commercial Construction Data - Excel."
https://ww2.energy.ca.gov/title24/documents/2022_Energy_Code_Data_for_Measure_Proposals.xlsx.
 - . 2018. "Impact Analysis: 2019 Update to the California Energy Efficiency Standards for Residential and Non-Residential Buildings." *energy.ca.gov*. June 29.
https://www.energy.ca.gov/title24/2019standards/post_adoption/documents/2019_Impact_Analysis_Final_Report_2018-06-29.pdf.
- California Public Utilities Commission (CPUC). 2015b. "Water/Energy Cost-Effectiveness Analysis: Revised Final Report." Prepared by Navigant Consulting, Inc. <http://www.cpuc.ca.gov/WorkArea/DownloadAsset.aspx?id=5360>.
- California Public Utilities Commission. 2015a. "Water/Energy Cost-Effectiveness Analysis: Errata to the Revised Final Report." Prepared by Navigant Consulting, Inc. . <http://www.cpuc.ca.gov/WorkArea/DownloadAsset.aspx?id=5350>.
- California Statewide Codes and Standards Program. 2016. "2016 Title 24, Part 6 Nonresidential Process Equipment and Systems." Energy Code Ace.
- California Statewide Utility Codes and Standards Team. 2019a.
"title24stakeholders.com." November. <https://title24stakeholders.com/wp-content/uploads/2019/09/Notes-T24-2022-Nov-7-Covered-Processes-Part-2.pdf>.
- . 2019b. "title24stakeholders.com." November. https://title24stakeholders.com/wp-content/uploads/2019/09/T24-Utility-Sponsored-Stakeholder-Meeting-1_NR-Covered-Processes-Part-2_MASTER.pdf.
 - . 2019c. "title24stakeholders.com." November. <https://title24stakeholders.com/wp-content/uploads/2019/09/Submeasure-Proposal-Summaries-Covered-Processes-2.pdf>.
- California Utilities Statewide Codes and Standards Team. 2013. "Codes and Standards Enhancement Initiative: Final Report: Compressed Air Systems."
- CEA Technologies. 2007. "Compressed Ai Energy Efficiency Reference Guide."
- Compressed Air & Gas Institute. n.d. *10 Steps to Savings*.
<https://www.cagi.org/working-with-compressed-air/benefits/10-steps-to-savings.aspx>.
- . 2016. *Compressed Air & Gas Handbook*.

- . n.d. "Technical Brief - Sizing Compressed Air Equipment." Accessed 2020.
<https://www.cagi.org/pdfs/Sizing-Technical-Brief-Final.pdf>.
- CSA Group. 2016. "Monitoring and Energy Performance Measurements of Compressed Air Systems." C837-16. CSA Group.
- Energy + Environmental Economics. 2016. "Time Dependent Valuation of Energy for Developing Building Efficiency Standards: 2019 Time Dependent Valuation (TDV) Data Sources and Inputs." Prepared for the California Energy Commission. July. http://docketpublic.energy.ca.gov/PublicDocuments/16-BSTD-06/TN212524_20160801T120224_2019_TDV_Methodology_Report_7222016.pdf.
- Energy + Environmental Economics. 2020. "Time Dependent Valuation of Energy for Developing Building Efficiency Standards: 2022 Time Dependent Valuation (TDV) and Source Energy Metric Data Sources and Inputs."
- Ettenson, Lara , and Christa Heavey. 2015. *California's Golden Energy Efficiency Opportunity: Ramping Up Success to Save Billions and Meet Climate Goals*. Natural Resources Defense Council & Environmental Entrepreneurs (E2).
- Federal Reserve Economic Data. n.d. <https://fred.stlouisfed.org> .
- Goldman, Charles, Merrian C. Fuller, Elizabeth Stuart, Jane S Peters, Marjorie McRay, Nathaniel Albers, Susan Lutzenhiser, and Mersiha Spahic. 2010. *Energy Efficiency Services Sector: Workforce Size and Expectations for Growth*. Lawrence Berkeley National Laboratory.
- Greenstone, Michael, Christopher Knittel, Catherine Wolfram, Andrew Campbell, Karen Notsund, and Kathy Nagel. 2019. *Unlocking Industrial Energy Efficiency Through Optimized Energy Management Systems*. California Energy Commission.
- Hernandez-Herrera, Hernan, Jorge Silva-Ortega, Vicente Leonel Martinez Diaz, Zaid Garcia Sanchez, Gilberto Gonzalez Garcia, Sandra Exorcia, and Habid Zarate. 2020. "Energy Savings Measures in Compressed Air Systems." *International Journal of Energy Economics and Policy* 414-422.
- Hessmer, Clair, James Olmsted, Samantha Meserve, and Ram Kondapi. 2015. "Compressed Air System Energy Efficiency Upgrades, Implemented vs. Underutilized Measures." *ACEEE Summer Study on Energy Efficiency in Industry*.
- Hoetzel, Jan. n.d. *Permanent Compressed Air System Metering and Monitoring (Compressed Air Best Practices)*. <https://www.airbestpractices.com/system-assessments/compressor-controls/permanent-compressed-air-system-metering-and-monitoring>.

- Kaeser Compressors. 2019. *Compressed Air System Installation Guide*.
- Kenney, Michael, Heather Bird, and Heriberto Rosales. 2019. *2019 California Energy Efficiency Action Plan*. Publication Number: CEC - 400 - 2019 - 010 - CMF, California Energy Commission.
- Marshall, Ron. n.d. "California Energy Commission and Lightapp Cloud-Based Software Begin Monitoring Study." *Compressed Air Best Practices*.
<https://www.airbestpractices.com/system-assessments/compressor-controls/california-energy-commission-and-lightapp-cloud-based-software>.
- . n.d. "Energy Performance Indicators Support ISO 50001 and ISO 50006." *Compressed Air Best Practices*.
- . 2014. "Piping System Tips for Energy Efficiency." *Compressed Air Best Practices*.
- . 2017. "Get active about monitoring your compressed air system efficiency." *Plant Services*, April.
- . 2018. "Money in your pocket: Fix your compressed air system leaks." *Plant Services*, July 16.
- . 2013. "Who's Designing Your Compressed-Air Piping System?" *Plant Services*.
- McHugh, J., Naff, D., Eilert, P., McGaraghan, M. & Gonzalez, A.. 2013. "Mass Producing Industrial Energy Efficiency through Building Energy Codes." *Proceedings of the 2013 Summer Study on Energy Efficiency in Industry*. Washington, D.C.: American Council for Energy Efficient Economy.
<https://mchughenergy.com/papers/ACEEE%20Mass%20Produce%20Indust%20Eff.pdf>.
- National Energy Assistance Directors' Association. 2011. *2011 National Energy Assistance Survey Final Report*.
<http://www.appriseinc.org/reports/Final%20NEADA%202011%20Report.pdf>.
- Rampley, Warwick, and Ron Marshall. 2020. "Compressed Air Alliance: Taking the pain out of your compressed air system." *Australian Manufacturing Technology*.
- Saidur, R., N.A. Rahim, and M. Hasanuzzaman. 2009. "A review on compressed-air energy use and energy savings." *Renewable and Sustainable Energy Reviews* 1135-1153.
- State of California, Employment Development Department. n.d.
<https://www.labormarketinfo.edd.ca.gov/cgi/dataanalysis/areaselection.asp?table name=industry> .
- Statewide CASE Team. 2019. "title24stakeholders.com." *Nonresidential Covered Processes Part 2 Meeting Notes*. December 4.

<https://title24stakeholders.com/wp-content/uploads/2019/09/Notes-T24-2022-Nov-7-Covered-Processes-Part-2.pdf>.

- Stone, Nehemiah, Jerry Nickelsburg, and William Yu. 2015. *Codes and Standards White Paper: Report - New Home Cost v. Price Study*. Pacific Gas and Electric Company. Accessed February 2, 2017.
<http://docketpublic.energy.ca.gov/PublicDocuments/Migration-12-22-2015/Non-Regulatory/15-BSTD-01/TN%2075594%20April%202015%20Codes%20and%20Standards%20White%20Paper%20-%20Report%20-%20New%20Home%20Cost%20v%20Price%20Study.pdf>.
- Therkelsen, Peter, Prakash Rao, Aimee McKane, Ridah Sabouni, Yannick Tamm, and Paul Scheihing. 2015. "Development of an Enhanced Payback Function for the Superior Energy Performance Program." *ACEEE Summer Study on Energy Efficiency in Industry*. Buffalo, NY.
- Thornberg, Christopher, Hoyu Chong, and Adam Fowler. 2016. *California Green Innovation Index - 8th Edition*. Next 10.
- U.S. Census Bureau, Population Division. 2014. "Annual Estimates of the Resident Population: April 1, 2010 to July 1, 2014."
<http://factfinder2.census.gov/bkmk/table/1.0/en/PEP/2014/PEPANNRES/0400000US06.05000>.
- U.S. Department of Commerce. 2019. "Bureau of Economic Analysis." *Regional Data*.
<https://apps.bea.gov/itable/iTable.cfm?ReqID=70&step=1#reqid=70&step=1&isuri=1>.
- U.S. Department of Energy. n.d. *Better Buildings, Johnson Controls: Compressed Air Efficiency Program*. Accessed 2020.
<https://betterbuildingsolutioncenter.energy.gov/showcase-projects/johnson-controls-compressed-air-efficiency-program>.
- . 2004. "Energy Tips - Compressed Air Tip Sheet #3." *Industrial Technologies Program*. Department of Energy.
- . 2016. "Improving Compressed Air System Performance: A Sourcebook for Industry." Office of Energy Efficiency and Renewable Energy.
- U.S. EPA (United States Environmental Protection Agency). 2011. "Emission Factors for Greenhouse Gas Inventories." Accessed December 2, 2013.
<http://www.epa.gov/climateleadership/documents/emission-factors.pdf>.
- United States Environmental Protection Agency. 1995. "AP 42, Fifth Edition Compilation of Air Pollutant Emissions Factors, Volume 1: Stationary Point and Area

Sources." <https://www.epa.gov/air-emissions-factors-and-quantification/ap-42-compilation-air-emissions-factors#5thed>.

United States Environmental Protection Agency. 2018. "Emissions & Generation Resource Integrated Database (eGRID) 2016."
<https://www.epa.gov/energy/emissions-generation-resource-integrated-database-egrid>.

van Ormer, Hank, and Scott van Ormer. 2005. "Compressed Air Systems: The Secret is in the Pipe." *Chemical Processing*.

Xenergy, Inc. 2001. *Assessment of the Market for Compressed Air Efficiency Services*. US DOE.

Zabin, Carol, and Karen Chapple. 2011. *California Workforce Education & Training Needs Assessment: For Energy Efficiency, Distributed Generation, and Demand Reponse*. University of California, Berkeley Donald Vial Center on Employment in the Green Economy. Accessed February 3, 2017.
http://laborcenter.berkeley.edu/pdf/2011/WET_Appendices_ALL.pdf.

Appendix A: Statewide Savings Methodology

The California compressed air market, construction, and growth rates are not captured in the California Energy Commission construction forecast that is used as a default for CASE Reports. Compressed air systems covered by code predominately exist in industrial facilities not captured in the construction forecast categories, except in the miscellaneous category. The miscellaneous category is the largest in both existing building stock and expected 2023 floorspace construction. According to the construction forecast, the expected 2023 construction growth rate is about 2.2 percent (31,970,000 ft²). However, the miscellaneous category includes a variety of building types industrial and otherwise. So, the Statewide CASE Team opted to use compressed air market survey data to estimate the market size.

The total California compressed air energy consumption for the manufacturing sector was estimated using available data as shown in Table 48. The California manufacturing compressed air footprint was estimated to be about 9,784 GWh/year.

Table 48: Manufacturing Compressed Air Market Size

Variable	Variable Name	Value	Source
2001 U.S. Compressed Air Energy Consumption (GWh/yr)	A	91,050	(Xenergy, Inc. 2001)
Avg California Share of U.S. Manufacturing GDP 2001-2018	B	10.7%	(U.S. Department of Commerce 2019)
Estimated 2019 California Compressed Air Energy Consumption (GWh/yr)	C	9,784	A*B

In order to estimate statewide potential, it was necessary to estimate the theoretical number of each prototype model in the state. This was done by combining the total estimated California market size, prototype system annual energy consumption, and market statistics as reported in a Department of Energy compressed air survey (Xenergy, Inc. 2001). As shown in Table 49, the Statewide CASE Team estimated the number of new construction and alteration sites for each prototype and proposed measure.

Table 49: Estimated Statewide Market Size by Prototype

Variable	Variable Name	System 1	System 2	System 3	System 4	Source
Approximate Fraction of Installed Systems by System Size	D	19%	54%	12%	16%	(Xenergy, Inc. 2001)
California Compressed Air Energy Consumption (GWh/yr)	E	1,817	5,240	1,192	1,536	C*D
Modeled System Energy (kWh/yr)	F	501,836	793,903	1,762,067	3,195,834	Section 4
Number of California Sites	G	3,621	6,600	676	481	1,000,000*E/F
Fraction of Sites with Piping Measure Opportunity	H	40%	40%	40%	40%	(Xenergy, Inc. 2001)
California Energy Commission Miscellaneous Building Type 2023 Forecast Growth Rate	I	2.2%	2.2%	2.2%	2.2%	California Energy Commission
Number of New Construction Prototype Sites per Year for Piping Measure	J	32	58	6	4	G*H*I
Fraction of Sites with Leak Opportunity	K	65%	65%	65%	65%	(Xenergy, Inc. 2001)
Number of New Construction Prototype Sites per Year for Leak Testing and Monitoring Measure	L	52	95	10	7	G*H*I
Air Compressor Estimated Useful Life (yr)	M	20	20	20	20	ASHRAE Handbook - Applications
Number of Alteration Prototype Sites per Year for Leak Testing and Monitoring Measure	N	118	214	22	16	G*K/M

Appendix B: Nominal Cost Savings

In Section 5.2 Energy Cost Savings Results, the present valued savings over a 15 year period of analysis is calculated using the TDV approach. When considering present value analysis over the 15-year period, energy costs savings escalate as energy rates increase but given the time value of money they are also discounted.

In this section, nominal cost is evaluated. Energy costs are escalating as in the TDV analysis but the time value of money is not included so the results are not discounted. The nominal energy cost savings for the four system prototypes are presented in Table 50, Table 51, and Table 52.

Table 50: Nominal TDV Energy Cost Savings Over 15-Year Period of Analysis – Pipe Sizing

Prototype	15-Year TDV Electricity Cost Savings (Nominal \$)	15-Year TDV Natural Gas Cost Savings (Nominal \$)	Total 15-Year TDV Energy Cost Savings (Nominal \$)
Prototype 1	\$208,646	N/A	\$208,646
Prototype 2	\$579,198	N/A	\$579,198
Prototype 3	\$710,374	N/A	\$710,374
Prototype 4	\$750,144	N/A	\$750,144

Table 51: Nominal TDV Energy Cost Savings Over 15-Year Period of Analysis – Leak Monitoring

Prototype	15-Year TDV Electricity Cost Savings (Nominal \$)	15-Year TDV Natural Gas Cost Savings (Nominal \$)	Total 15-Year TDV Energy Cost Savings (Nominal \$)
Prototype 1	\$147,798	N/A	\$147,798
Prototype 2	\$209,182	N/A	\$209,182
Prototype 3	\$482,488	N/A	\$482,488
Prototype 4	\$1,009,599	N/A	\$1,009,599

Table 52: Nominal TDV Energy Cost Savings Over 15-Year Period of Analysis – Leak Testing

Prototype	15-Year TDV Electricity Cost Savings (Nominal \$)	15-Year TDV Natural Gas Cost Savings (Nominal \$)	Total 15-Year TDV Energy Cost Savings (Nominal \$)
Prototype 1	\$35,015	N/A	\$35,015
Prototype 2	\$11,172	N/A	\$11,172
Prototype 3	\$22,386	N/A	\$22,386
Prototype 4	\$267,133	N/A	\$267,133

Appendix C: Environmental Impacts Methodology

Greenhouse Gas (GHG) Emissions Factors

As directed by Energy Commission staff, GHG emissions were calculated making use of the average emissions factors specified in the United States Environmental Protection Agency (U.S. EPA) Emissions & Generation Resource Integrated Database (eGRID) for the Western Electricity Coordination Council California (WECC CAMX) subregion (United States Environmental Protection Agency 2018). This ensures consistency between state and federal estimations of potential environmental impacts. The electricity emissions factor calculated from the eGRID data is 240.4 MTCO_{2e} per GWh. The Summary Table from eGrid 2016 reports an average emission rate of 529.9 pounds CO_{2e}/MWh for the WECC CAMX subregion. This value was converted to metric tons/GWh.

Avoided GHG emissions from natural gas savings attributable to sources other than utility-scale electrical power generation are calculated using emissions factors specified in Chapter 1.4 of the U.S. EPA's Compilation of Air Pollutant Emissions Factors (AP-42) (United States Environmental Protection Agency 1995). The U.S. EPA's estimates of GHG pollutants that are emitted during combustion of one million standard cubic feet of natural gas are: 120,000 pounds of CO₂ (Carbon Dioxide), 0.64 pounds of N₂O (Nitrous Oxide) and 2.3 pounds of CH₄ (Methane). The emission value for N₂O assumed that low NO_x burners are used in accordance with California air pollution control requirements. The carbon equivalent values of N₂O and CH₄ were calculated by multiplying by the global warming potentials (GWP) that the California Air Resources Board used for the 2000-2016 GHG emission inventory, which are consistent with the 100-year GWPs that the Intergovernmental Panel on Climate Change used in the fourth assessment report (AR4). The GWP for N₂O and CH₄ are 298 and 25, respectively. Using a nominal value of 1,000 Btu per standard cubic foot of natural gas, the carbon equivalent emission factor for natural gas consumption is 5,454.4 metric tons per MMTherms.

GHG Emissions Monetization Methodology

The 2022 TDV energy cost factors used in the lifecycle cost-effectiveness analysis include the monetary value of avoided GHG emissions based on a proxy for permit costs (not social costs). To demonstrate the cost savings of avoided GHG emissions, the Statewide CASE Team disaggregated the value of avoided GHG emissions from the other economic impacts. The authors used the same monetary values that are used in the TDV factors – \$106.20 per metric tons CO_{2e}.

Water Use and Water Quality Impacts Methodology

The proposed measures have no impacts on water quality or water use.

Appendix D: California Building Energy Code Compliance (CBECC) Software Specification

All the compressed air measures are mandatory measures and as a result there are no trade-offs with other efficiency measures and compressed air systems are not modelled in the performance approach. There are no recommended revisions to the compliance software as a result of this code change proposal.

Appendix E: Impacts of Compliance Process on Market Actors

This appendix discusses how the recommended compliance process, which is described in Section 2.5, could impact various market actors. Table 53 identifies the market actors who would play a role in complying with the proposed change, the tasks for which they would be responsible, their objectives in completing the tasks, how the proposed code change could impact their existing work flow, and ways negative impacts could be mitigated. The information contained in Table 53 is a summary of key feedback the Statewide CASE Team received when speaking to market actors about the compliance implications of the proposed code changes.

Table 53: Roles of Market Actors in the Proposed Compliance Process

Market Actor	Task(s) In Compliance Process	Objective(s) in Completing Compliance Tasks	How Proposed Code Change Could Impact Work Flow	Opportunities to Minimize Negative Impacts of Compliance Requirement
Mechanical Acceptance Test Technician	Complete NA7.13 Compressed Air Acceptance Tests	<ul style="list-style-type: none"> • Quickly complete compliance documents • Coordinate with installer to address any compliance issues determined when completing the acceptance form • Minimize coordination during construction 	<ul style="list-style-type: none"> • Additional tests would be required. Specifically leak testing of new pipe greater than 100 ft, verification of compressor FDD/controllers, and review of the design criteria for compressed air distribution piping. • May require additional training for analysis of data from FDD monitoring systems 	<ul style="list-style-type: none"> • Revise code language to remove assessment of “online capacity”. Using nominal capacity would reduce time needed to complete construction inspection of acceptance test. • Work with compressed air system designer/installer. Many of tests may already be part of the existing commissioning process • New controls requirements could provide a single location for much of the data needed for acceptance tests.
Facility Manager	None	None	Additional training on maintenance of new instruments and FDD systems	<ul style="list-style-type: none"> • Explain how data could also help plan for growth/additional capacity and reduce maintenance costs by identifying leaks and other significant issues.
Commissioning Agent (CxA)	None	None	<ul style="list-style-type: none"> • Additional work involved in leak testing newly added pipe • Additional work in commissioning new sensors and controls for FDD 	New testing requirements may be integrated into existing commissioning process.

Compressed Air System Designer (often design/build)	<ul style="list-style-type: none"> • Identify requirements for compliance with proposed measure • Coordinate with commissioning agent/field technician as necessary 	<ul style="list-style-type: none"> • Quickly and easily determine requirements based on scope • Demonstrate compliance with calculations required for other design tasks • Clearly communicate system requirements to constructors • 	<ul style="list-style-type: none"> • Additional testing of new hard pipe • New controls and design requirements for new systems that is not currently required. This would increase first cost for many of the systems. 	Create a detailed commissioning process and report to ensure that equipment would meet requirements to be checked by the field technician.
Plans Examiner	<ul style="list-style-type: none"> • Checks that updated NA7.13 Compressed Air Acceptance Tests is submitted and completed appropriately • Checks building plans, equipment specifications, and controls sequence are in accordance with compliance documents 	<ul style="list-style-type: none"> • Quickly and easily determine if proposed system is in compliance • Quickly and easily provide correction comments to resolve issues 	Pipe Sizing: plans examiner would need to review for proper size on NRCC form, against construction docs.	Provide education on new requirements to familiarize party with new code change.
Energy Consultant	<ul style="list-style-type: none"> • Identify relevant requirements • Confirm data on forms is compliant • Confirm plans/specifications match data on forms • Provide correction comments if necessary 	<ul style="list-style-type: none"> • Quickly and easily determine if data in forms meets requirements • Quickly and easily determine if plans/specs match forms • Quickly and easily provide correction comments that would resolve issue 	<ul style="list-style-type: none"> • Would need to ensure specified systems comply with the code measure • Would need to ensure proper compliance documentation 	Removal of “online” capacity through code cleanup would make verification of code compliance easier to check. Specifically, short term M&V would no longer be necessary to verify.

<p>Building Inspector</p>	<p>Checks completed NRCA document for compliance</p>	<ul style="list-style-type: none"> • Quickly and easily determine if acceptance document has been properly completed • Quickly and easily provide correction comments to field technician to resolve issues 	<p>New and modified requirements that would need to be verified</p>	<p>Provide education on new requirements to familiarize party with additional acceptance forms</p>
---------------------------	--	---	---	--

Appendix F: Summary of Stakeholder Engagement

Collaborating with stakeholders that might be impacted by proposed changes is a critical aspect of the Statewide CASE Team's efforts. The Statewide CASE Team aims to work with interested parties to identify and address issues associated with the proposed code changes so that the proposals presented to the Energy Commission in this Final CASE Report are generally supported. Public stakeholders provide valuable feedback on analyses and help identify and address challenges to adoption including cost effectiveness, market barriers, technical barriers, compliance and enforcement challenges, or potential impacts on human health or the environment. Some stakeholders also provide data that the Statewide CASE Team uses to support analyses.

This appendix summarizes the stakeholder engagement that the Statewide CASE Team conducted when developing and refining the recommendations presented in this report.

Utility-Sponsored Stakeholder Meetings

Utility-sponsored stakeholder meetings provide an opportunity to learn about the Statewide CASE Team's role in the advocacy effort and to hear about specific code change proposals that the Statewide CASE Team is pursuing for the 2022 code cycle. The goal of stakeholder meetings is to solicit input on proposals from stakeholders early enough to ensure the proposals and the supporting analyses are vetted and have as few outstanding issues as possible. To provide transparency in what the Statewide CASE Team is considering for code change proposals, during these meetings the Statewide CASE Team asks for feedback on:

- Proposed code changes
- Assumptions and results for analyses
- Data to support assumptions
- Compliance and enforcement, and
- Technical and market feasibility

The Statewide CASE Team hosted one stakeholder meeting for the compressed air measures via webinar. Please see below for dates and links to event pages on [Title24Stakeholders.com](https://www.title24stakeholders.com). Materials from the meeting, such as slide presentations, proposal summaries with code language, and meeting notes, are included in the bibliography section of this report (California Statewide Utility Codes and Standards Team 2019a) (California Statewide Utility Codes and Standards Team 2019b) (California Statewide Utility Codes and Standards Team 2019c).

Meeting Name	Meeting Date	Event Page from Title24stakeholders.com
First Round of Covered Processes Utility-Sponsored Stakeholder Meeting	Thursday, November 7, 2019	https://title24stakeholders.com/event/nonresidential-covered-processes-utility-sponsored-stakeholder-meeting/

The first round of utility-sponsored stakeholder meetings occurred from September to November 2019 and were important for providing transparency and an early forum for stakeholders to offer feedback on measures being pursued by the Statewide CASE Team. The objectives of the first round of stakeholder meetings were to solicit input on the scope of the 2022 code cycle proposals; request data and feedback on the specific approaches, assumptions, and methodologies for the energy impacts and cost-effectiveness analyses; and understand potential technical and market barriers. The Statewide CASE Team also presented initial draft code language for stakeholders to review.

The second round of utility-sponsored stakeholder meetings occurred from January to April 2020 and provided updated details on proposed code changes. The second round of meetings introduced early results of energy, cost-effectiveness, and incremental cost analyses, and solicited feedback on refined draft code language. The compressed air proposals were not presented during the second Covered Processes meeting.

Utility-sponsored stakeholder meetings were open to the public. For each stakeholder meeting, two promotional emails were distributed from info@title24stakeholders.com. One email was sent to the entire Title 24 Stakeholders listserv, totaling over 1,900 individuals, and a second email was sent to a targeted list of individuals on the listserv depending on their subscription preferences. The Title 24 Stakeholders' website listserv is an opt-in service and includes individuals from a wide variety of industries and trades, including manufacturers, advocacy groups, local government, and building and energy professionals. Each meeting was posted on the Title 24 Stakeholders' LinkedIn page⁷ (and cross-promoted on the Energy Commission LinkedIn page) two weeks before each meeting to reach out to individuals and larger organizations and channels outside of the listserv. The Statewide CASE Team conducted extensive personal outreach to stakeholders identified in initial work plans who had not yet opted into the listserv. Exported webinar meeting data captured attendance numbers and individual comments, and recorded outcomes of live attendee polls to evaluate stakeholder participation and support.

⁷ Title 24 Stakeholders' LinkedIn page can be found here: <https://www.linkedin.com/showcase/title-24-stakeholders/>.

Statewide CASE Team Communications

The Statewide CASE Team held personal communications over email and phone with numerous stakeholders when developing this report. An incomplete list of the stakeholders who contributed to the development of this report are listed in Table 54. These stakeholders were instrumental in aiding the development of the proposed code language and in gathering information necessary to qualitatively and quantitatively justify the proposal.

Table 54: Partial List of Contributing Stakeholders

Organization	Contacts
Air Leak Detection	Tyler Costa
Air Systems Management	Chris Beals
CDI Meters	Roger Dennison
Compressed Air Best Practices	Rod Smith
Compressed Air Challenge	David Booth
Draw Professional Services & Atlas Copco Compressors	Frank Moskowitz
Energair Solutions	Van Tran, Nicolas De Deken
Energy350	Justin Ramsay, Meg Waltner
Engineered Air	Sean Edwards
Ingersoll Rand	Mark Krisa, George Mankos, Brian Freeman, Steve Eaton
Kaeser Compressors	Keith Baker, Wayne Perry, Werner Rauer, Neil Mehlretter
Lightapp Technologies	Elhay Farkash, Henry Velasquez
Marshall Compressed Air Consulting	Ron Marshall
Petro Chemical Energy	Darren Woodruff
Q-AIR California	Richard Walsh
Quincy-Scales Compressors	Bill Scales
SIGA Compressed Air Solutions	Jan Hoetzel, Ashlee Berger, Megan Orange
SMC Corporation of America	Jon Jensen
Sparks Dynamics	Mac Mottley
VPIstruments	Pascal Van Putten, Cynthia Kuiper
Willdan	Mike Casey, Doug Thieme, Ron Allen

The Statewide CASE Team engaged with these stakeholder industry experts to discuss all relevant aspects of the compressed air marketplace and proposed measures. These conversations were used to develop measure costs, code language, exceptions, assumptions, measure barriers, and to assess the market readiness for the proposed measures. These conversations included discussions of compressed air leak conditions

and field practices, existing codes, pressure and leak testing practices, pipe sizing conditions and practices, monitoring system benefits and appropriateness, and overall recommendations for code language changes.