

Laboratories

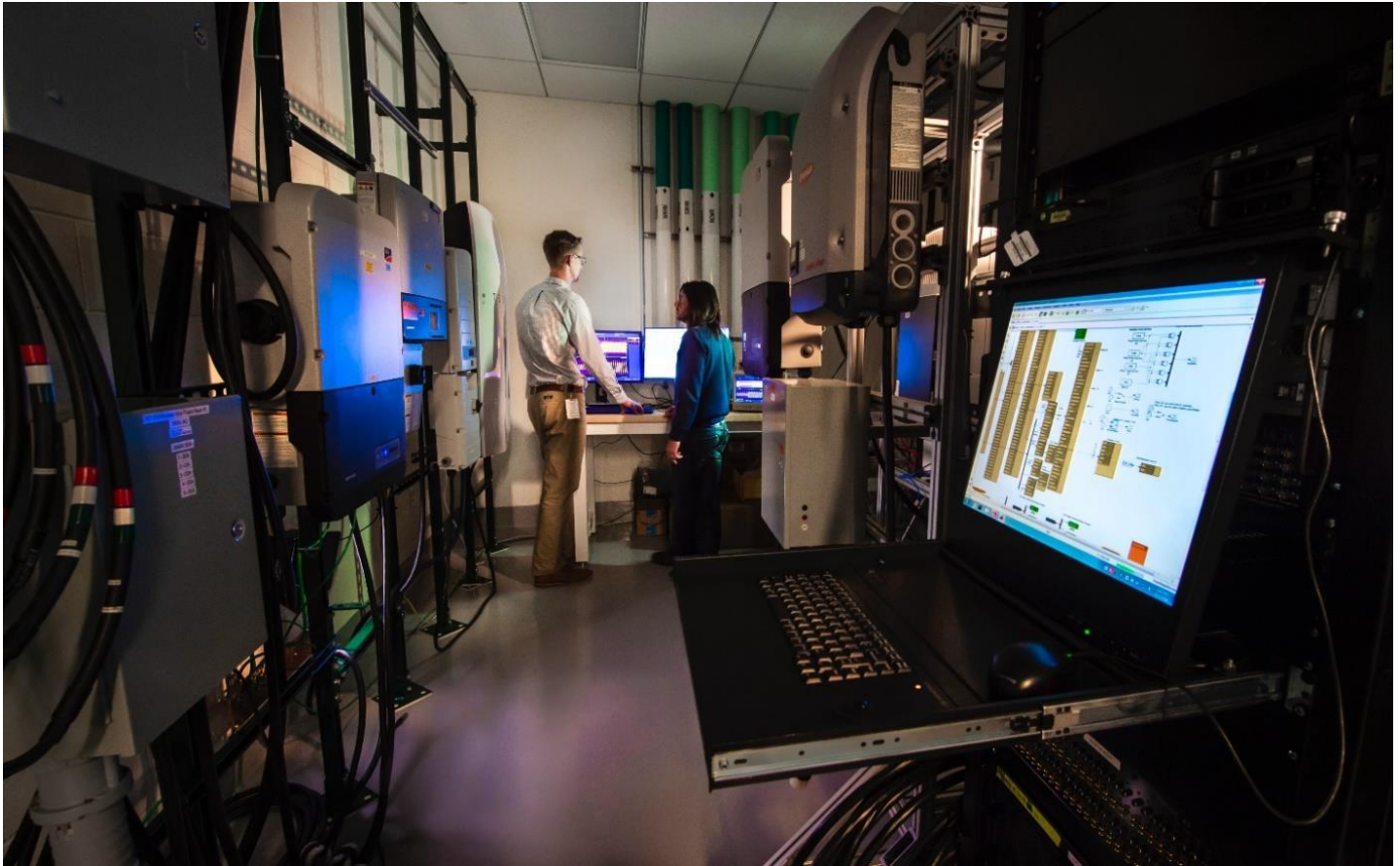

Covered Processes

Abed Alkhatib (Energy Solutions)

Jeff Stein, Hwakong Cheng (Taylor Engineers)

Jon McHugh (McHugh Energy Consultants)

July 2023

Draft CASE Report



This report was prepared by the California Statewide Codes and Standards Enhancement (CASE) Program that is funded, in part, by California utility customers under the auspices of the California Public Utilities Commission.

Copyright 2023 Pacific Gas and Electric Company, Southern California Edison, San Diego Gas & Electric Company, Los Angeles Department of Water and Power, and Sacramento Municipal Utility District. All rights reserved, except that this document may be used, copied, and distributed without modification.

Neither Pacific Gas and Electric Company, Southern California Edison, San Diego Gas & Electric Company, Los Angeles Department of Water and Power, Sacramento Municipal Utility District or any of its employees makes any warranty, express or implied; or assumes any legal liability or responsibility for the accuracy, completeness or usefulness of any data, information, method, product, policy or process disclosed in this document; or represents that its use will not infringe any privately-owned rights including, but not limited to, patents, trademarks or copyrights.

Document Information

Category: **Codes and Standards**

Keywords: Statewide Codes and Standards Enhancement (CASE) Initiative; California Statewide Utility Codes and Standards Team; Codes and Standards Enhancements; 2025 California Energy Code; 2025 Title 24, Part 6; California Energy Commission; energy efficiency; laboratory; heat recovery; ventilation; occupancy sensor; laboratory exhaust; reheat.

Authors: Jeff Stein, Hwakong Cheng (Taylor Engineers)
Abed Alkhatib (Energy Solutions)
Jon McHugh (McHugh Energy Consultants)

Prime Contractor Energy Solutions

Project Management: California Statewide Utility Codes and Standards Team: Pacific Gas and Electric Company, Southern California Edison, San Diego Gas & Electric Company, Sacramento Municipal Utility District, and Los Angeles Department of Water and Power.

Table of Contents

Executive Summary	ix
1. Introduction	1
2. Unoccupied Setback	4
2.1 Measure Description	4
2.2 Market Analysis	13
2.3 Energy Savings	24
2.4 Cost and Cost Effectiveness	28
2.5 First-Year Statewide Impacts	31
3. Heat Recovery	34
3.1 Measure Description	34
3.2 Market Analysis	45
3.3 Energy Savings	56
3.4 Cost and Cost Effectiveness	59
3.5 First-Year Statewide Impacts	63
4. Exhaust Fan Control	66
4.1 Measure Description	66
4.2 Market Analysis	78
4.3 Energy Savings	88
4.4 Cost and Cost Effectiveness	93
4.5 First-Year Statewide Impacts	93
5. Reheat Limitation (4-Pipe VAV)	96
5.1 Measure Description	96
5.2 Market Analysis	105
5.3 Energy Savings	119
5.4 Cost and Cost Effectiveness	122
5.5 First-Year Statewide Impacts	128
6. Addressing Energy Equity and Environmental Justice	131
7. Proposed Revisions to Code Language	132
7.1 Guide to Markup Language	132
7.2 Standards	132
7.3 Reference Appendices	138
7.4 ACM Reference Manual	143
7.5 Compliance Forms	153
8. Bibliography	155
Appendix A: Statewide Savings Methodology	156

Appendix B: Embedded Electricity in Water Methodology	161
Appendix C: California Building Energy Code Compliance (CBECC) Software Specification	162
Appendix D: Environmental Analysis	172
Appendix E: Discussion of Impacts of Compliance Process on Market Actors	175
Appendix F: Summary of Stakeholder Engagement	177
Appendix G: Energy Cost Savings in Nominal Dollars	180
Appendix H: Interactive Effects of Different Measures	181

List of Tables

Table 1: Scope of Code Change Proposal for Unoccupied Setback	xxi
Table 2: Scope of Code Change Proposal for Heat Recovery	xxvi
Table 3: Scope of Code Change Proposal for Exhaust Fan Control	xxvi
Table 4: Scope of Code Change Proposal for Reheat Limitation	xxvii
Table 5: California Construction Industry, Establishments, Employment, and Payroll in 2022 (Estimated)	15
Table 6: Specific Subsectors of the California Commercial Building Industry Impacted by Proposed Change to Code/Standard by Subsector in 2022 (Estimated)	16
Table 7: California Building Designer and Energy Consultant Sectors in 2022 (Estimated)	17
Table 8: Employment in California State and Government Agencies with Building Inspectors in 2022 (Estimated)	18
Table 9: Estimated Impact that Adoption of the Proposed Measure would have on the California Commercial Construction Sector	20
Table 10: Estimated Impact that Adoption of the Proposed Measure would have on the California Building Designers and Energy Consultants Sectors	20
Table 11: Estimated Impact that Adoption of the Proposed Measure would have on California Building Inspectors	20
Table 12: Net Domestic Private Investment and Corporate Profits, United States (U.S.)	22
Table 13: Prototype Buildings Used for Energy, Demand, Cost, and Environmental Impacts Analysis	25
Table 14: Modifications Made to Standard Design in Each Prototype to Simulate Proposed Code Change	26
Table 15: First-Year Electricity Savings (kWh) Per Square Foot – Unoccupied Setback	27

Table 16: First-Year Peak Demand Reduction (W) Per Square Foot – Unoccupied Setback.....	56
Table 17: First-Year Natural Gas Savings (kBtu) Per Square Foot - Unoccupied Setback	56
Table 18: First-Year Source Energy Savings (kBtu) Per Square Foot - Unoccupied Setback.....	56
Table 19: First-Year Lifecycle Energy Savings (kBtu) Per Square Foot - Unoccupied Setback.....	56
Table 20: 2026 PV Lifecycle Energy Cost Savings Over 30-Year Period of Analysis – Per Square Foot – New Construction– Laboratory	28
Table 21: 2026 PV Lifecycle Energy Cost Savings Over 30-Year Period of Analysis – Per Square Foot – Alterations– Laboratory.....	29
Table 22: 30-Year Cost-Effectiveness Summary Per Square Foot – New Construction/Additions	30
Table 23: 30-Year Cost-Effectiveness Summary Per Square Foot – Alterations.....	31
Table 22: Statewide Energy and Energy Cost Impacts – New Construction	32
Table 24: Statewide Energy and Energy Cost Impacts – Alterations	32
Table 23: First-Year Statewide GHG Emissions Impacts	33
Table 24: California Construction Industry, Establishments, Employment, and Payroll in 2022 (Estimated).....	47
Table 25: Specific Subsectors of the California Commercial Building Industry Impacted by Proposed Change to Code/Standard by Subsector in 2022 (Estimated).....	47
Table 26: California Building Designer and Energy Consultant Sectors in 2022 (Estimated)	49
Table 27: Employment in California State and Government Agencies with Building Inspectors in 2022 (Estimated).....	50
Table 28: Estimated Impact that Adoption of the Proposed Measure would have on the California Commercial Construction Sector	51
Table 29: Estimated Impact that Adoption of the Proposed Measure would have on the California Building Designers and Energy Consultants Sectors.....	52
Table 30: Estimated Impact that Adoption of the Proposed Measure would have on California Building Inspectors	52
Table 31: Net Domestic Private Investment and Corporate Profits, U.S.	53
Table 32: Prototype Buildings Used for Energy, Demand, Cost, and Environmental Impacts Analysis	57
Table 33: Modifications Made to Standard Design in Each Prototype to Simulate Proposed Code Change.....	58

Table 34: First-Year Electricity Savings (kWh) Per Square Foot – Heat Recovery	59
Table 35: First-Year Peak Demand Reduction (kW) Per Square Foot - Heat Recovery	88
Table 36: First-Year Natural Gas Savings (kBtu) Per Square Foot - Heat Recovery	88
Table 37: First-Year Source Energy Savings (kBtu) Per Square Foot - Heat Recovery	88
Table 38: Total Per-Unit Long-term Systemwide Cost (LSC) Savings Lifecycle - Heat Recovery.....	88
Table 39: 2026 PV Lifecycle Energy Cost Savings Over 30-Year Period of Analysis – Per Square Foot – New Construction and Additions– Laboratory.....	60
Table 39: 2026 PV Lifecycle Energy Cost Savings Over 30-Year Period of Analysis – Per Square Foot – Alterations– Laboratory.....	89
Table 40: 30-Year Cost-Effectiveness Summary Per Square Foot – New Construction/Additions	63
Table 40: 30-Year Cost-Effectiveness Summary Per Square Foot – Alterations.....	92
Table 41: Statewide Energy and Energy Cost Impacts – New Construction and Additions	64
Table 41: Statewide Energy and Energy Cost Impacts – Alterations	64
Table 42: First-Year Statewide GHG Emissions Impacts	65
Table 43: California Construction Industry, Establishments, Employment, and Payroll in 2022 (Estimated).....	79
Table 44: Specific Subsectors of the California Commercial Building Industry Impacted by Proposed Change to Code/Standard by Subsector in 2022 (Estimated).....	80
Table 45: California Building Designer and Energy Consultant Sectors in 2022 (Estimated).....	81
Table 46: Employment in California State and Government Agencies with Building Inspectors in 2022 (Estimated).....	82
Table 47: Estimated Impact that Adoption of the Proposed Measure would have on the California Building Designers and Energy Consultants Sectors.....	84
Table 48: Estimated Impact that Adoption of the Proposed Measure would have on California Building Inspectors	84
Table 49: Net Domestic Private Investment and Corporate Profits, U.S.	86
Table 50: Prototype building: simplified controls energy consumption comparison.....	91
Table 51: Prototype Buildings Used for Energy, Demand, Cost, and Environmental Impacts Analysis	91
Table 52: First-Year Electricity Savings (kWh) Per Square Foot-- Exhaust Fan Control	93

Table 53: First-Year Peak Demand Reduction (kW) Per Square Foot— Exhaust Fan Control	123
Table 54: First-Year Source Energy Savings (kBtu) Per Square Foot— Exhaust Fan Control	123
Table 55: First-Year Lifecycle Energy Savings (kBtu) Per Square Foot – Exhaust Fan Control	123
Table 56: Statewide Energy and Energy Cost Impacts – New Construction and Additions	94
Table 56: Statewide Energy and Energy Cost Impacts – Alterations	124
Table 57: First-Year Statewide GHG Emissions Impacts	95
Table 58: California Construction Industry, Establishments, Employment, and Payroll in 2022 (Estimated)	110
Table 59: Specific Subsectors of the California Commercial Building Industry Impacted by Proposed Change to Code/Standard by Subsector in 2022 (Estimated)	111
Table 60: California Building Designer and Energy Consultant Sectors in 2022 (Estimated)	112
Table 61: Employment in California State and Government Agencies with Building Inspectors in 2022 (Estimated)	113
Table 62: Estimated Impact that Adoption of the Proposed Measure would have on the California Commercial Construction Sector	115
Table 63: Estimated Impact that Adoption of the Proposed Measure would have on the California Building Designers and Energy Consultants Sectors	115
Table 64: Estimated Impact that Adoption of the Proposed Measure would have on California Building Inspectors	115
Table 65: Net Domestic Private Investment and Corporate Profits, U.S.	117
Table 66: Prototype Buildings Used for Energy, Demand, Cost, and Environmental Impacts Analysis	120
Table 67: Modifications Made to Standard Design in Each Prototype to Simulate Proposed Code Change	121
Table 68: First-Year Electricity Savings (kWh) Per Square Foot – Reheat Limitation 4-Pipe VAV	122
Table 69: First-Year Peak Demand Reduction (kW) Per Square Foot— Reheat Limitation 4-Pipe VAV	153
Table 70: First-Year Natural Gas Savings (kBtu) Per Square Foot— Reheat Limitation 4-Pipe VAV	153
Table 71: First-Year Source Energy Savings (kBtu) Per Square Foot— Reheat Limitation 4-Pipe VAV	153

Table 72: Total Per-Unit Long-term Systemwide Cost (LSC) Savings Lifecycle Reheat Limitation 4-Pipe VAV	153
Table 73: 2026 PV Lifecycle Energy Cost Savings Over 30-Year Period of Analysis – Per Square Foot – New Construction and Additions– Laboratory.....	123
Table 74. Incremental First Cost for 4-Pipe VAV at Project SF	125
Table 75. Incremental First Cost for 4-pipe VAV at Project Pleasanton	126
Table 76: 30-Year Cost-Effectiveness Summary Per Square Foot – New Construction/Additions	127
Table 76: 30-Year Cost-Effectiveness Summary Per Square Foot – Alterations.....	158
Table 77: Statewide Energy and Energy Cost Impacts – New Construction and Additions	128
Table 77: Statewide Energy and Energy Cost Impacts – Alterations	129
Table 78: First-Year Statewide GHG Emissions Impacts	130
Table 79: Estimated New Nonresidential Construction in 2026 (Million Square Feet) .	158
Table 80: Estimated New Nonresidential Construction Impacted by Proposed Code Change in 2026, by Climate Zone and Building Type (Million Square Feet)	159
Table 81: Percentage of Nonresidential Floorspace Impacted by Proposed Code Change in 2026, by Building Type.....	160
Table 83: Roles of Market Actors in the Proposed Compliance Process.....	176
Table 84: Utility-Sponsored Stakeholder Meetings	178
Table 85: Engaged Stakeholders.....	179
Table 86: Combined Nominal Lifecycle Energy Cost Savings Over 30-Year Period of Analysis – Per Square Foot – New Construction – Laboratory- Unoccupied Setback- Heat Recovery-Reheat Limitation.....	180

List of Figures

Figure 1. Typical control schematic of lab exhaust fan system with heat recovery coil. xvi
Figure 2. Typical schematic of lab exhaust heat recovery system. xvii
Figure 3. Typical schematic of lab air handler with heat recovery coil. xviii
Figure 4. Components of lab exhaust flows. 68
Figure 5. Typical control schematic of lab exhaust fan system with heat recovery coil. .36
Figure 6. Typical schematic of lab exhaust heat recovery system.37
Figure 7. Typical schematic of lab air handler with heat recovery coil.38
Figure 8. ASHRAE 90.1-2022..... 39
Figure 9. Schematic of lab exhaust to heat recovery chiller.42

Figure 10. Incremental cost data for heat recovery.....	91
Figure 12: Dispersion modelling examples.....	70
Figure 13. 2-Pipe VAV lab schematic.	98
Figure 14. 4-Pipe VAV lab schematic.	99
Figure 15. 4-Pipe VAV lab with heat recovery.....	100
Figure 16. Typical 4-Pipe VAV lab ductwork plan.	101
Figure 17. Typical 4-Pipe VAV lab hydronic plan.	101
Figure 18. Typical 4-Pipe VAV lab plumbing plan (showing condensate gravity drained to nearby floor sinks and lab sinks).	102
Figure 19. Typical 4-Pipe VAV control schematic.	103
Figure 20. CA design dew point histogram.....	106
Figure 21. Typical lab with CHW and HW coils at the zones.....	107
Figure 22. Typical CHW + HW zone coil detail.	108
Figure 23. Isometric view of typical lab with CHW + HW zone coils.....	109
Figure 24. 6-Way changeover valve piping schematic.....	124
Figure 25: CBECC ventilation and exhaust user interface.....	163
Figure 26: Fixed ventilation scenario.	163
Figure 27: Proposed measure scenario.....	164
Figure 28- Exhaust fan CBECC inputs.	169

Executive Summary

This is a draft report. The Statewide CASE Team encourages readers to provide comments on the proposed code changes and the analyses presented in this draft report. When possible, provide supporting data and justifications in addition to comments. Suggested revisions will be considered when refining proposals and analyses. The Final CASE Report will be submitted to the California Energy Commission in summer 2023.

Email comments and suggestions to DJ Joh (djoh@energy-solution.com) and info@title24stakeholders.com by August 2, 2023. Comments will not be released for public review or will be anonymized if shared.

Introduction

The Codes and Standards Enhancement (CASE) Initiative presents recommendations to support the California Energy Commission’s (CEC’s) efforts to update the California Energy Code (Title 24, Part 6) to include new requirements or to upgrade existing requirements for various technologies. Three California Investor-Owned Utilities (IOUs) — Pacific Gas and Electric Company, San Diego Gas and Electric, and Southern California Edison — and two Publicly Owned Utilities — Los Angeles Department of Water and Power, and Sacramento Municipal Utility District (herein referred to as the Statewide CASE Team when including the CASE Author) — sponsored this effort. The program’s goal is to prepare and submit proposals that would result in cost-effective enhancements to improve energy efficiency and energy performance in California buildings. This report and the code change proposals presented herein are a part of the effort to develop technical and cost-effectiveness information for proposed requirements on building energy-efficient design practices and technologies.

The Statewide CASE Team submits code change proposals to the CEC, the state agency that has authority to adopt revisions to Title 24, Part 6. The CEC will evaluate proposals submitted by the Statewide CASE Team and other stakeholders. The CEC may revise or reject proposals. See the CEC’s 2025 Title 24 website for information about the rulemaking schedule and how to participate in the process:

<https://www.energy.ca.gov/programs-and-topics/programs/building-energy-efficiency-standards/2025-building-energy-efficiency>.

The Statewide CASE Team gathered input from stakeholders to inform them of the proposal and associated analyses and justifications. Stakeholders also provided input on the code compliance and enforcement process. See Appendix F for a summary of stakeholder engagement.

The goal of this Draft CASE Report is to present a cost-effective code change proposal for unoccupied setback, exhaust air heat recovery, exhaust fan control, and limiting reheat in laboratories. The report contains pertinent information supporting the code change.

The Statewide CASE Team is recommending five measures in this proposal:

1. Modification to the existing lab VAV requirements in Section 140.9(c)1 to include unoccupied setback requirements.
2. Adding new requirements for heat recovery for some laboratory exhaust systems.
3. Adding additional design fan power and control combinations to the prescriptive requirements in Section 140.9(c) for laboratory exhaust fan system power consumption
4. Adding a new requirement to limit reheat by requiring zone level heating/cooling capacity to avoid overcooling at the air handler and then reheating at downstream zones.
5. Code cleanup in Sections 100.0 (scope), 100.1 (definitions), and 140.4 (prescriptive requirements for space conditioning systems), including expanding the scope to include the L occupancy group.

Each proposal is described in more detail below.

Unoccupied Setback

Proposal Description

Proposed Code Change

The proposed code change would extend the existing laboratory variable air volume (VAV) requirement in Section 140.9(c)1 to clarify that labs must have the ability to reduce airflows when occupied, and that they would need to further reduce airflows when unoccupied. With this change, variable airflow systems will save energy at all required occupied. It would also modify existing requirements so they would apply to all laboratory spaces instead of just applying to spaces with minimum circulation air changes per hour (ACH) and spaces with 10 ACH rates or less.

- **Type of change:** Prescriptive
- **Building types impacted:** Buildings with laboratory spaces. Occupancy classifications that may include laboratory spaces include:
 - Business Group B
 - Educational Group E

- Laboratories Group L (proposed to be newly covered)
- High-Hazard Group H
- **Threshold:** The proposal applies to laboratory spaces of any size. See proposed definition of laboratory space in Section 7.
- **Additions and Alterations:** The proposal includes an exception for new zones on an existing constant volume system but otherwise it applies to all additions and alterations.
- **Field Verification and Acceptance Tests:** The acceptance tests would be modified to include a test demonstrating that the zone airflow rate setpoints are reduced when a laboratory space transitions from occupied to unoccupied.
- **Compliance Software Updates:** The compliance software would be updated so ventilation rates when occupied and unoccupied are simulated more accurately.
- **Newly Regulated System or Technology?** This proposal does not add requirements for a system or technology that were not regulated previously.

Justification

The laboratories occupancy is one of the fastest growing space use types in California, driven in large part by the thriving biotech industry in California. Laboratories also have much higher heating and cooling requirements than many other space types, driven in large part by the fact that laboratories are typically 100 percent outside air, have high ventilation rates, and are ventilated 24/7. Modulating the ventilation rate from the worst-case design maximum rate to the lowest possible rate is the most significant way to reduce HVAC energy use in labs.

The proposed change would also address an unintended negative consequence of the current requirements that only applies to labs where the minimum circulation rate to comply with code or accreditation standards is 10 ACH or less. The 10 ACH threshold is resulting in some projects artificially increasing airflow rates to avoid the first cost of complying with VAV requirements. Removing the 10 ACH threshold avoids this negative consequence.

Background Information

The lab VAV requirements in Section 140.9(c)1 were added to Title 24 in 2013 and apply to systems where minimum circulation rates are 10 ACH or less. Existing code requires that lab exhaust be designed so they have variable volume controls on supply and exhaust fans. An exception is provided for laboratory exhaust systems where constant volume is required by code, the authority having jurisdiction (AHJ), or the facility environmental health and safety division [Exception 1 to §140.9(c)1].

This proposal would extend the existing VAV requirement to achieve additional savings during unoccupied times. Many existing labs already have lower minimum ventilation requirements when unoccupied, but code does not require systems to reduce ventilation when spaces are unoccupied. With this proposal, if a lab space is allowed to have lower ventilation rates when unoccupied, then code would require the VAV system have the ability to turn down ventilation to those minimum allowable rates.

Though the proposed language indicates occupied airflow rates of 1.0 cfm/ft² and unoccupied airflow rates of 0.67 cfm/ft², this requirement would not mandate those rates specifically as there are allowances where higher rates are required for code, accreditation, or environmental health and safety requirements. This provides flexibility where higher rates may be required, such as based on the results of a hazard evaluation and risk assessment.

The proposal would delete Exception 1, which currently exempts systems that are required to be constant volume by the authority having jurisdiction, environmental health and safety, or code. However, this exception is effectively maintained by allowing the occupied and unoccupied airflow rates to be set based on alternative requirements. If those rates are set to be equal, then a system may still be designed to be constant volume.

As discussed in Section 2.2.2, most labs already have lighting controls that can also be used to control HVAC systems, so the additional control requirements are minimal.

Heat Recovery

Proposal Description

Proposed Code Change

The proposed code change would add a requirement for heat recovery for laboratory exhaust systems. Specifically, it would add a new requirement in Section 140.9(c)6 (Prescriptive Requirements for Laboratories and Factories) requiring exhaust air heat recovery for some labs.

- **Type of change:** Prescriptive
- **Building types impacted:** Buildings with laboratory spaces. Occupancy Classifications that may include laboratory spaces include:
 - Business Group B
 - Educational Group E
 - Laboratories Group L
- **Threshold:** The proposal would apply to new lab buildings with over 10,000 cfm of lab exhaust.

- **Additions/Alterations:** The proposal would not apply to additions or alterations of systems that do not currently have heat recovery. If the addition or alteration is to be served by a new supply and exhaust system, then the proposal would apply.
- **Field Verification / Acceptance Tests:** The existing acceptance tests for demonstrating compliance with the existing exhaust air heat recovery requirements in Section 140.4(q) can be used for lab spaces. The proposal would add labs as one of the space types that must meet exhaust air heat recovery requirements.
 - **Compliance Software Updates:** No significant updates would be required to the software, but the existing heat recovery modules would need to be updated so they apply to lab spaces. The Standard Design would need to be updated to include heat recovery for labs, in the same way that it is included in the Standard Design for other space types. The Standard Design heat recovery effectiveness would match the proposed required effectiveness for labs.
 - **Newly Regulated System or Technology?** This proposal does not add requirements for a system or technology that was not regulated previously.

The marked up code language is available in Section 7 of this document ([hyperlink to marked up language in Section 7](#)).

Justification

Exhaust air heat recovery is common for laboratories because it is highly cost effective. In many cases it reduces the project's first cost in addition to providing annual energy savings. Heat recovery can reduce both the peak cooling load and the peak heating load. Reducing the peak cooling load allows the cooling equipment to be downsized and reducing the peak heating load allows the heating equipment to be downsized.

Background Information

Lab exhaust heat recovery is typically achieved with a coil run-around system, as opposed to a plate-type or wheel-type air-to-air heat exchanger. This is to mitigate the risk of cross-contamination from the exhaust air stream to outside air stream.

With a run-around system, a fluid coil (water or glycol) is added into the exhaust airstream. Additional pump(s) and piping are added to transfer heat from the exhaust coil to a coil in the supply air handler(s). If the supply air handler has a heating coil, then that coil can also be used as the heat recovery coil. If the air handler does not have a heating coil, then a recovery coil must be added. See Section 3.1.2.2 for figures that depict the system designs. The control sequences for this type of lab exhaust heat recovery system are typically quite simple.

Exhaust Fan Control

Proposal Description

Proposed Code Change

This measure would add a fourth fan power and control option that allows an intermediate level of design fan power and an intermediate level of complexity for the fan speed control. The system would be designed with variable speed control and with the capability of safely decreasing exhaust stack flow by at least 40 percent (reduce to 60 percent of design flow) in response to VAV zone controls. The system would be designed so that at minimum airflow and under ASHRAE one percent design windspeed conditions (exceeded only 86 hours per year) the discharge would maintain downwind concentrations below health and odor limits. This type of control does not rely on the maintained accuracy of windspeed or contaminant sensors but rather the inherent modelled design of stack height, minimum velocity of exhaust flow and the dispersion characteristics of the site.

This proposed change would add an additional design fan power and control combination to the prescriptive requirements in Section 140.9(c)3 for laboratory exhaust fan system power consumption. These requirements would apply to all laboratory fan exhaust systems with a design flow rate greater than 10,000 cubic feet per minute (cfm). The laboratory occupancies covered are occupancy classes B (business), L (laboratory) and H (hazardous). This requirement would also apply to replaced laboratory ventilation systems.

[Hyperlink to full code language proposal.](#)

Justification

In general low fan wattage requirements necessitate the use of tall stacks to provide sufficient dispersion of exhausted contaminants at moderate velocities. Sometimes zoning regulations the height of stacks and thus the current code allows no limits on fan energy if one controls fan speed with respect to wind speed or contaminant concentrations in the exhaust plenum. This proposal provides added design flexibility for laboratory exhaust systems by adding an alternate pathway for complying with the fan system power consumption requirements. This pathway places a 1.3 W/cfm fan power limit at design conditions but also requires that the fan control system be able to vary the speed of the fans and reduce airflow through the exhaust stack to no more than 60 percent of design airflow and be able to reduce fan power to no greater than 40 percent of design fan power safely at a minimum stack flow rate that is pre-calculated to avoid exposing the lab occupants to unacceptable odor or contaminant concentrations. The location and the height of the exhaust stacks are designed so that at the ASHRAE one percent wind speed the design contaminant concentrations would be below downwind

concentrations limits for health and odor, as defined by the 2018 American Conference of Governmental Industrial Hygienists Threshold Limit Values and Biological Exposure Indices. A detailed description of the necessary considerations in exhaust system needed to protect the lab occupants and the public from contaminants is given in Section 6.4 of ANSI/ASSP Z9.5-2022.

The design of the geometry and placement of exhaust and intakes are such so that there is no risk of contaminant exposure and odors at the minimum exhaust system flow rate and at the ASHRAE 99 percent windspeed. This control takes a worst-case approach – minimum exhaust volume and high windspeed to provide a margin of safety so a simple control can be used.

Background Information

The current fan power requirements place a 0.65 W/cfm design fan power limit with constant exhaust stack flow rate controls or a 1.3 W/cfm fan power limit at design conditions with stack flow rate controls in response to wind speed or exhaust plenum concentrations. Existing options currently use advanced controls to vary the flow rate in response to measured wind speed or measured contaminants in the exhaust plenum. The safety and energy savings of these other advanced controls rely on maintaining the accuracy of the wind velocity sensors or the contaminant concentration sensors. This can thus require higher maintenance than this new additional exhaust system design and control option. The new proposed option is based on maintaining exhaust system pressures for laboratory exhaust system controls and measurement of exhaust stack flow rates. All of these systems modulate a bypass damper and vary the speed of the exhaust fan to achieve the desired lab exhaust rates and exhaust stack flow rates.

This proposal would require that when the stack air flow rate is dropped to 60 percent, the fan power at this condition will be no greater than 40 percent of the design fan power. For variable volume systems, which operate most hours at reduced flow rates, the savings are significant. Some of the other options currently allowed use advanced controls vary the flow rate in response to measured windspeed or measured contaminants in the exhaust plenum. The safety and energy savings of these other advanced controls rely on maintaining the accuracy of the wind velocity sensors or the contaminant concentration sensors. In addition to these advanced controls, this proposal includes the “simple turn-down control” which is more robust as it is essentially “open loop” and relies on the precalculated airflow rates for close to worst case wind speed conditions. This approach does not have the same level of maintenance requirements.

This proposed simple control requires airflow modelling of the exhaust and air intake design in the context of its surroundings. The two other more complex controls approaches also require airflow modelling to develop the correct mapping between minimum stack velocity versus windspeed or stack contaminant level. It should be noted

that the controls work in the same fashion for labs in all occupancy groups (B, L and H), what differs on a lab by lab basis is the expected amount and type of hazardous materials. The amount and toxicity of hazardous materials impacts the maximum allowable concentration levels for researchers and the public which in turn affects minimum allowable air changes per hour (ACH) and the target concentrations in the dispersion analysis of the stack exhaust.

Reheat Limitation (4-Pipe VAV)

Proposal Description

Proposed Code Change

The proposed code change would add a new requirement in section 140.9 (prescriptive requirements for laboratories) that would eliminate reheat in most labs. The proposed change will not prevent any labs from meeting any special pressurization or cross contamination or humidity control or high exhaust requirements.

- **Type of change:** Prescriptive
- **Building types impacted:** Buildings with laboratory spaces. Occupancy Classifications that may include laboratory spaces include:
 - Business Group B
 - Educational Group E
 - Laboratories Group L
- **Threshold:** The proposal would apply to laboratory spaces of any size. Title 24 defines laboratory spaces as follows:

Laboratory, Scientific Area is a room or area where research, experiments, and measurement in medical and physical sciences are performed requiring examination of fine details. The area may include workbenches, countertops, scientific instruments, and associated floor spaces. Scientific laboratory does not refer to film, computer, and other laboratories where scientific experiments are not performed.

- **Additions/Alterations:** The proposal would not apply to additions or alterations of existing systems that do not already meet the proposal. The proposal would apply if the space is already served by a system that meets the proposal or the space will be served by new supply and exhaust systems.
- **Field Verification / Acceptance Tests:** No changes required.
- **Compliance Software Updates:** No updates are required to the software, as EnergyPlus already has the ability to model 4-pipe VAV (please confirm). The ACM rules will be updated to make 4-pipe VAV the baseline system for labs.

- **Newly Regulated System or Technology?** This proposal does not add requirements for a system or technology that was not regulated previously.

Here is a [hyperlink to proposed language for reheat limitation](#).

Justification

4-pipe VAV, chilled beams, and VRF systems are already common in labs and can meet the proposed requirements. However, as first costs for a 2-pipe VAV system are less expensive than the aforementioned systems, a builder who has no interest or incentive for lowering the energy-use of a lab may opt for the more inexpensive 2-pipe system with a gas boiler and reheat systems.

A 4-pipe VAV system will have dramatically lower energy use than a 2-pipe system and is lifecycle cost effective. Note that heat recovery measure and minimizing reheat with 4-pipe VAV (as proposed here) are not mutually exclusive. The energy savings of heat recovery are not affected by minimizing reheat and vice versa.

Background Information

Current code allows for conditioned air to be reheated to control both humidity and temperature in areas where strict humidity control may be required while providing a comfortable temperature setpoint for the space. This method of cooling air below the dew point to remove humidity and then heating the air can be very energy intensive, requiring larger HVAC equipment such as heat exchangers, condensers, and evaporator units as they work against each other.

Reheat is the process of adding heat to air that has already been cooled and dehumidified, which can consume a significant amount of energy. Even when eliminating reheat, HVAC systems can maintain comfortable temperatures and humidity levels while using less energy by using a 4-pipe VAV system. In California’s dry climate, most of the reheat used in traditional VAV systems is the result of tempering the air at the air handler to the temperature needed for the zone with the greatest heat rejection needs and then reheating air for zones with lower cooling needs or with heating needs.

Code Clean-Up including Scope of Laboratory Requirements

Proposal Description

Proposed Code Change

This proposal specifically includes L occupancies in the scope of Title 24, part 6. In section 100(a)1, the current scope includes “all buildings that are Occupancy Group A, B, E, F, H, I, M, R, S, or U...” These are all the Occupancy Group types in the International Building Code (IBC). The scope but does not include Group L (laboratory)

occupancy classification special occupancy classification developed for the California Building Code (CBC). The CBC is the IBC with the California amendments such as the definition of the Group L classification. The omission of the L occupancy group from the scope appears to be an oversight because Title 24, part 6 regulates the mechanical and lighting systems of labs and it currently regulates buildings with lower quantities of hazardous materials occupancy group B (business) as well as those with higher amounts of hazardous material Occupancy Class H (high-hazard). This oversight would be corrected by adding occupancy Group L to the list of covered buildings.

This proposal adds to the definitions section a definition of laboratory as *“A room, building or area where the use and storage of hazardous materials are utilized for testing, analysis, instruction, research or developmental activities.”* This definition is a direct quote of the definition of laboratory in the California Building Code. For completeness, this proposal updated the definition of nonresidential buildings to include Occupancy Group L so there is no ambiguity whether a laboratory building or laboratory space is considered a nonresidential building.

In the current code, the exhaust fan power requirements are based on units of watts per cfm. However, it was not fully clear what the cfm refers to. As shown in Figure 6 laboratory exhaust systems there are three different airflow rates associated with the same fan system:

- The exhaust flow from all spaces served by the exhaust system
- The flowrate of air entering the exhaust fans including the exhaust air from the lab spaces served by the exhaust system and the bypass air entering the fans.
- The flowrate leaving the exhaust stack. This includes the flowrate of the air entering the exhaust fans plus any entrained air by an induction fan system

It was clear that the cfm did not include entrained air such as one might have in an induction fan, but it was not clear if the airflow rate included bypass air or not. Strictly speaking the bypass air is not exhaust air but rather outside air that is mixed with exhaust air to increase the velocity of stack velocity without increasing the use of conditioned indoor air. The new update clarifies in Section 140.9(c)3 that *“exhaust fan system airflow rate is the total of the airflow rates entering the exhaust fans which includes exhaust air and bypass air but does not include entrained or induced airflow downstream of the exhaust fans.”*

Justification

Laboratories are found in three building occupancy groups: B (business including labs in secondary schools), H (high-hazard) and L (laboratory). The amount of allowable hazardous materials is lowest in B occupancies, and intermediate amount is allowable in L occupancies and the highest amount is allowable in H occupancies. The current standard covers the laboratory containing occupancies with the highest and lowest

amounts of allowed hazardous materials, it is reasonable to have the same energy efficiency features for the laboratory occupancy with the intermediate allowed quantities of hazardous materials.

What changes between the various hazard categories are the ventilation airflow rates “to with code, accreditation, or facility environmental health and safety department requirements...” Given that all the other occupancy groups listed in the scope are in the IBC, it is reasonable to consider that the omission of the L Occupancy Group was an oversight that would be fixed by the changes to scope recommended in this proposal.

Including the definition of laboratory space from the California Building Code (Title 24, part 2) in the definitions section of Title 24, part 6 creates a consistency across the building codes. There is a definition of Scientific Laboratory Area under Nonresidential Function Areas section of the definitions as they relate to lighting power densities. These correspond to Primary Function Areas in Table 140.6-C Area Category Method - Lighting Power Density Values. This definition is not as broad as the definitions in the CBC and not as focused on hazardous materials – the prime purpose of the requirements associated with ventilation of laboratory space.

Background Information

The assignment of a given laboratory design to an Occupancy Group starts with identifying the maximum allowed quantities of hazardous materials are allowed for a given building configuration. The primary intents of the code requirements are protection of human health during normal operation, and containment of combustion gases, maintaining building integrity and safe evacuation during an unplanned worst-case explosion. Thus, greater amounts of hazardous materials are allowed for nonflammable, robust construction assemblies such as Type IA (concrete and protected steel) and correspondingly less hazardous materials are allowed in the more flammable classes down to type V. Similarly, the taller the building, which is harder to evacuate, the fewer the amount of hazardous materials allowed.

Tables 307.1(1) and 307.1(2) of the CBC define the maximum amount of hazardous material per control areas (enclosed spaces). These maximums are allowed for Occupancy Group H (high-hazard) construction.

Occupancy Group B (Business) construction is limited to the number of control areas per floor, and the percentage of the maximum allowable quantity per control area.¹ This varies from 5% of quantity per control area and 1 control area per floor for buildings taller than 9 stories to 100% of the maximum allowed hazardous material per control area for single story buildings with up 4 control areas.

¹ See Table 414.2.2 in the 2022 CBC.

Occupancy Group L (Laboratory) allows a larger percentage of hazardous material per laboratory suite and a larger number of laboratory suites per floor. For buildings that are 15-20 stories, Occupancy Group L buildings with Type IA construction are allowed to have up to 25 percent the amount of the maximum amount of hazardous material from Tables 307.1(1) and 307.1(2) and up to 4 laboratory suites per floor, whereas for single story buildings of the same construction 100 percent of the maximum amount of hazardous material is allowed per laboratory suite with an unlimited number of laboratory suites per floor.

In discussions with staff in the California Office of the State Fire Marshal, laboratory construction is found in B, H and L Occupancy Groups. In some cases, the L Occupancy Group construction requirements can be more expensive than H-4. The selection of Occupancy Group selected for a project is based on a number of considerations in addition to the amount of hazardous materials that are intended to be used or stored on site.

The required flowrates vary depending upon the specifics of what the amounts and types of hazardous materials. These airflow rates are not set by Title 24, part 6 but are from "...code, accreditation, or facility environmental health and safety department requirements." Similarly the proposed fan control requirements are based on dilution principles developed by the American Society of Safety Professionals in the national standard, ANSI/ASSP Z9.5 "Laboratory Ventilation."

Depending upon the source one looks at, the L Occupancy Group was introduced in the 2007 or 2010 IBC. The 2008 Title 24, part 6 energy code introduced the lighting power density requirements for the "laboratory, scientific" primary function in the area category method. The prescriptive requirement for VAV laboratory exhaust was added to the 2013 version of Title 24, part 6. Six years later, laboratory exhaust fan power limits, fan controls and occupancy sensing fume hood controls were added to the 2019 Title 24 part 6 requirements. It appears the issue of the L category had been "flying under the radar." Lighting systems in L occupancies were being regulated for their power and controls.

Based on a recent survey of building officials by CEC staff, Group L lab designers are already complying with Title 24, because designers and building departments do not realize that L is currently exempt. Adding Occupancy Group L to the list of occupancies which are covered by Title 24, Part 6 will better match current practice.

There is no statewide database of building construction Occupancy Groups associated with laboratories. The statewide CASE Team contacted four laboratory designers and asked them for their best estimate of the prevalence of laboratories in B (business), L (laboratory) and H (high-hazard) construction occupancy groups. The average estimate was 61 percent B occupancy, 30 percent L occupancy and 9 percent H occupancy. The variability in the estimates for the fraction of labs in L occupancies was broad: the

highest estimate was 55 percent and the lowest was 4 percent. Anecdotally, L occupancies are found in junior and 4-year colleges, research facilities, and various biotech, and chemical industrial production sites. Laboratories in K-12 settings have small amounts of hazardous materials, so these applications are unlikely to need an L occupancy group classification.

Scope of Code Change Proposals

Table 1 summarizes the scope of the proposed changes and which sections of standards, Reference Appendices, Alternative Calculation Method (ACM) Reference Manuals, and compliance documents that would be modified as a result of the proposed change(s).

Table 1: Scope of Code Change Proposals

Proposal Name	Type of Requirement	Prescriptive
Unoccupied Setback	Applicable Climate Zones	All Climate Zones
	Modified Section(s) of Title 24, Part 6	140.9 (c) 1
	Modified Title 24, Part 6 Appendices	None
	Would Compliance Software Be Modified	Yes. Section: 5.6.6
	Modified Compliance Document(s)	None
Heat Recovery	Type of Requirement	Prescriptive
	Applicable Climate Zones	All Climate Zones
	Modified Section(s) of Title 24, Part 6	140.9 (c) 6
	Modified Title 24, Part 6 Appendices	None
	Would Compliance Software Be Modified	No
	Modified Compliance Document(s)	None
Exhaust Fan Control	Type of Requirement	Prescriptive
	Applicable Climate Zones	All Climate Zones
	Modified Section(s) of Title 24, Part 6	140.9 (c) 3
	Modified Title 24, Part 6 Appendices	NA-7
	Would Compliance Software Be Modified	Yes. Section: 5.7.3
	Modified Compliance Document(s)	None
Reheat Limitation	Type of Requirement	Prescriptive
	Applicable Climate Zones	All Climate Zones
	Modified Section(s) of Title 24, Part 6	140.9 (c) 5
	Modified Title 24, Part 6 Appendices	None
	Would Compliance Software Be Modified	Yes. Section 5.1.2
	Modified Compliance Document(s)	None

Market Analysis and Regulatory Assessment

Unoccupied Setback

The unoccupied setback measure would eliminate a previous exception that had incentivized builders to design an oversized HVAC system to avoid the existing VAV requirements for labs. In doing so, builders and designers would use existing technologies to detect occupancy in labs and allow for turn-down in the total ACH setpoints during unoccupied periods. The measure does not call for any new or emerging technologies to be implemented, but instead encourages the adoption and use of common sensors and control technologies in the design and construction of lab spaces.

Heat Recovery

The heat recovery measure seeks to remove an exception that allowed lab designers and builders to avoid putting in heat recovery systems. Heat recovery is a commonly used system designed to capture waste heat and reduce the peak heating or cooling loads, and many labs have already implemented this. Heat recovery would likely use a coil run-around system to avoid the risk of exhaust air contaminating outside air coming into the building. Compliance documents relating to the existing exhaust air heat recovery requirements in Section 140.4(q) could be used for this measure as well.

Exhaust Fan Control

This measure provides another way to comply with the fan power limits in the current code, by allowing for simplified fan controls allowing for turn-down using designs dictated by existing ASHRAE requirements for wind speeds and air flow modeling. This is a simpler alternative to current methods which requires a closed loop monitoring of wind speeds and contaminant concentration sensors, and thus may be a more attractive option for those looking for a simpler way to allow for system turn-down.

Reheat Limitation

Lab spaces currently have exceptions allowing for reheat, which allow designers and builders to use systems that offer a lower first-cost without regard for the operating costs. This measure would encourage the use of systems that are already in the market that eliminates the need for a reheat system, be it 4-pipe VAV, VRF, or chilled beam type systems. This measure does not require any new technologies, nor does it constrain the builders and designers to any one manufacturer.

Group L Occupancy

Adding L to the list of occupancies covered by Title 24 will increase the number labs that must comply with both the existing requirements in Title 24 and the newly proposed measures. Adding Group L to the scope does not require any new technologies, nor

does it unduly impact Group L labs. Based on a recent survey AHJ's by CEC staff, Group L lab designer are already complying with Title 24, because designers and AHJs do not realize that L is currently exempt. Adding occupancy Group L to the list of occupancies which are covered by Title 24, Part 6 will better match current practice. All existing Title 24 requirements and newly proposed requirements are safe and cost effective for Group L labs.

Cost Effectiveness

The proposed code changes were found to be cost effective for all climate zones where it is proposed to be required. The benefit-to-cost (B/C) ratio over the 30-year period of analysis ranged from 1.1 to 19.7.² See details in 2.4.5, 3.4.5, 4.4 and 5.4.5. for the methodology, assumptions, and results of the cost-effectiveness analysis.

California consumers and businesses would save more money on energy than they would spend to finance efficiency measures. As a result, over time this proposal would leave more money available for discretionary and investment purposes once the initial cost is paid off.

Statewide Energy Impacts: Energy, Water, and Greenhouse Gas (GHG) Emissions, and Embodied Carbon Impacts

First-year statewide energy impacts are represented by the following metrics: electricity savings in gigawatt-hours per year (GWh/yr), peak electrical demand reduction in megawatts (MW), natural gas savings in million therms per year (million therms/yr), source energy savings in millions of kilo British thermal units per year (million kBtu/yr), and lifecycle cost energy savings in millions of present valued dollars (million PV\$). See 2.5, 3.5, 4.5, and 5.5 for more details on the first-year statewide impacts. 2.3.2, 3.3.2, 4.3.2, and 5.3.2 contains details on the per-unit energy savings.

Avoided GHG emissions are measured in metric tons of carbon dioxide equivalent (metric tons CO₂e). Assumptions used in developing the GHG savings are provided in 2.5.2, 3.5.2, 4.5.2, and 5.5.2 and Appendix C of this report. The monetary value of avoided GHG emissions is included in the LSC hourly factors provided by CEC and is thus included in the cost-effectiveness analysis.

The proposed measures are not expected to have any direct impacts on water use or water quality, excluding impacts that occur at power plants. All of the measures except the fan control measure have impacts on cooling loads. As a result, labs that are air-

² The benefit-to-cost (B/C) ratio compares the benefits or cost savings to the costs over the 30-year period of analysis. Proposed code changes that have a B/C ratio of 1.0 or greater are cost effective. The larger the B/C ratio, the faster the measure pays for itself from energy cost savings.

conditioned by water cooled chillers, will have water savings due to less water being evaporated in cooling towers to reject the heat from air conditioning.

These measures do not have additional reductions from embodied carbon.

Compliance and Enforcement

Overview of Compliance Process

The compliance processes are described in 2.1.5, 3.1.5, 4.1.5, and 5.1.5. Impacts that the proposed measure would have on market actors is described in Appendix E. The Statewide CASE Team worked with stakeholders to develop a recommended compliance and enforcement process and to identify the impacts this process would have on various market actors.

Addressing Energy Equity and Environmental Justice

The Statewide CASE Team assessed the potential impacts of the proposed measure, and based on a preliminary review, the measure is unlikely to have significant impacts on energy equity or environmental justice, therefore reducing the impacts of disparities in DIPs. The Statewide CASE Team does not recommend further research or action at this time but is open to receiving feedback and data that may prove otherwise. Please reach out to Nancy Metayer (nmetayer@energy-solution.com) and Marissa Lerner (mlerner@energy-solution.com) for further engagement.

Full details addressing energy equity and environmental justice can be found in Section **Error! Reference source not found.** of this report.

1. Introduction

This is a draft report intended to allow for public review and comment before the Final Report is issued. The Statewide CASE Team encourages readers to provide comments on the proposed code changes and the analyses presented. When possible, include supporting data and justifications in addition to comments. The Statewide CASE Team will review all suggestions and consider them when revising and refining proposals and analyses. The Final CASE Report will be submitted to the California Energy Commission in July 2023.

Email comments and suggestions to DJ Joh (djoh@energy-solution.com) and info@title24stakeholders.com by August 2, 2023. Comments will not be released for public review or will be anonymized if shared.

The Codes and Standards Enhancement (CASE) initiative presents recommendations to support the California Energy Commission's (CEC's) efforts to update California's Energy Code (Title 24, Part 6) to include new requirements or to upgrade existing requirements for various technologies. The three California Investor-Owned Utilities (IOUs) — Pacific Gas and Electric Company, San Diego Gas and Electric, and Southern California Edison – and two Publicly Owned Utilities — Los Angeles Department of Water and Power and Sacramento Municipal Utility District (herein referred to as the Statewide CASE Team when including the CASE Author) — sponsored this effort. The program's goal is to prepare and submit proposals that would result in cost-effective enhancements to improve energy efficiency and energy performance in California buildings. This report and the code change proposal presented herein are a part of the effort to develop technical and cost-effectiveness information for proposed requirements on building energy-efficient design practices and technologies.

The CEC is the state agency that has authority to adopt revisions to Title 24, Part 6. One of the ways the Statewide CASE Team participates in the CEC's code development process is by submitting code change proposals to the CEC for consideration. CEC will evaluate proposals the Statewide CASE Team and other stakeholders submit and may revise or reject proposals. See [the CECs 2025 Title 24 website](#) for information about the rulemaking schedule and how to participate in the process.

The goal of this Draft CASE Report is to present code change proposals for unoccupied setback, heat recovery, exhaust fan control, and reheat limitations. The report contains pertinent information supporting the proposed code change.

When developing the code change proposal and associated technical information presented in this report, the Statewide CASE Team worked with many industry stakeholders including HVAC designers, builders, hood manufacturers, and lab designers. The proposal incorporates feedback received during public stakeholder workshops that the Statewide CASE Team held on January 31, 2023, and May 10, 2023.

Sections 2 through 5 of the report describe in detail each of the proposals. Section 2 addresses unoccupied setback, Section 3 addresses heat recovery, Section 4 addresses Exhaust Fan Control, and Section 5 addresses Reheat Limitations. The following is a summary of the contents within each Section:

- Section X.1 Measure Description – Measure Description of this Draft CASE Report provides a description of the measure and its background. This section also presents a detailed description of how this code change is accomplished in the various sections and documents that make up the Title 24, Part 6 Standards.
- Section X.2 Market Analysis – Market Analysis includes a review of the current market structure.
- Section X.3 Energy Savings – Energy Savings presents the per-unit energy, demand reduction, and energy cost savings associated with the proposed code change. This section also describes the methodology that the Statewide CASE Team used to estimate per-unit energy, demand reduction, and energy cost savings.
- Section X.4 Cost and Cost Effectiveness – Cost and Cost Effectiveness presents the lifecycle cost and cost-effectiveness analysis. This includes a discussion of the materials and labor required to implement the measure and a quantification of the incremental cost. It also includes estimates of incremental maintenance costs, i.e., equipment lifetime and various periodic costs associated with replacement and maintenance during the period of analysis.
- Section X.5 First-Year Statewide Impacts – First-Year Statewide Impacts presents the statewide energy savings and environmental impacts of the proposed code change for the first year after the 2025 code takes effect. This includes the amount of energy that would be saved by California building owners and tenants and impacts (increases or reductions) on material with emphasis placed on any materials that are considered toxic. Statewide water consumption impacts are also reported in this section.

Section 6 – Addressing Energy Equity and Environmental Justice presents the potential impacts of proposed code changes on disproportionately impacted populations (DIPs).

Section 7 – Proposed Revisions to Code Language concludes the report with specific recommendations with ~~strikeout~~ (deletions) and underlined (additions) language for the standards, Reference Appendices, and Alternative Calculation Method (ACM) Reference Manual. Generalized proposed revisions to sections are included for the compliance manual and compliance documents.

Section 8 – Bibliography presents the resources that the Statewide CASE Team used when developing this report.

- Appendix A: Statewide Savings Methodology presents the methodology and assumptions used to calculate statewide energy impacts.
- Appendix B: Embedded Electricity in Water Methodology presents the methodology and assumptions used to calculate the electricity embedded in water use (e.g., electricity used to draw, move, or treat water) and the energy savings resulting from reduced water use.
- Appendix C: California Building Energy Code Compliance (CBECC) Software Specification presents relevant proposed changes to the compliance software (if any).
- Appendix D: Environmental Analysis presents the methodologies and assumptions used to calculate impacts on GHG emissions and water use and quality.
- Appendix E: Discussion of Impacts of Compliance Process on Market Actors presents how the recommended compliance process could impact identified market actors.
- Appendix F: Summary of Stakeholder Engagement documents the efforts made to engage and collaborate with market actors and experts.
- Appendix G: Energy Cost Savings in Nominal Dollars presents energy cost savings over the period of analysis in nominal dollars.
- Appendix H: Interactive Effects of Different Measures presents energy and cost savings when four measures are working together at a lab.

The California IOUs offers free energy code training, tools, and resources for those who need to understand and meet the requirements of Title 24, Part 6. The program recognizes that building codes are one of the most effective pathways to achieve energy savings and GHG reductions from buildings – and that well-informed industry professionals and consumers are key to making codes effective. With that in mind, the California IOUs provide tools and resources to help both those who enforce the code, as well as those who must follow it. Visit EnergyCodeAce.com to learn more and to access content, including a glossary of terms.

2. Unoccupied Setback

2.1 Measure Description

2.1.1 Proposed Code Change

The proposed code change would modify to the existing laboratory variable air volume (VAV) (VAV) requirement in Section 140.9(c)1 to clarify that labs must have the ability to reduce airflows when occupied, and that they would need to further reduce airflows when unoccupied. With this change, variable airflow systems will save energy at all required occupied. It would also modify existing requirements so they would apply to all laboratory spaces instead of just applying to spaces with minimum circulation air changes per hour (ACH) and spaces with 10 ACH rates or less.

- **Type of change:** Prescriptive
- **Building types impacted:** Buildings with laboratory spaces. Occupancy classifications that may include laboratory spaces include:
 - Business Group B
 - Educational Group E
 - Laboratories Group L (proposed to be newly covered)
 - High-Hazard Group H
- **Threshold:** The proposal applies to laboratory spaces of any size. See proposed definition of laboratory space in Section 7.
- **Additions and Alterations:** The proposal includes an exception for new zones on an existing constant volume system but otherwise it applies to all additions and alterations.
- **Field Verification and Acceptance Tests:** The acceptance tests would be modified to include a test demonstrating that the zone airflow rate setpoints are reduced when a laboratory space transitions from occupied to unoccupied.
- **Compliance Software Updates:** The compliance software would be updated so ventilation rates when occupied and unoccupied are simulated more accurately.
- **Newly Regulated System or Technology?** This proposal does not add requirements for a system or technology that were not regulated previously.

2.1.2 Justification and Background Information

2.1.2.1 Justification

The laboratories occupancy is one of the fastest growing space use types in California, driven in large part by the thriving biotech industry in California. Laboratories also have

much higher heating and cooling requirements than many other space types, driven in large part by the fact that laboratories are typically 100 percent outside air, have high ventilation rates, and are ventilated 24/7. Modulating the ventilation rate from the worst-case design maximum rate to the lowest possible rate is the most significant way to reduce HVAC energy use in labs.

The proposed change would address an unintended negative consequence of the current lab VAV requirement in section 140.9(c)1. The current requirement only applies to labs where the minimum circulation rate to comply with code or accreditation standards is 10 ACH or less. This has led many projects to claim their labs require 10 ACH and then to make the labs constant volume with 10 ACH, to avoid the increased first cost associated with VAV capability. The reality is that many of these labs may not require more than 6 ACH, even at design conditions: labs that might have been constant volume at 6 ACH without the code are instead built as constant volume at 10 ACH because of the code. The 10 ACH threshold allows projects to artificially increase airflow rates to avoid the first cost of making the lab have VAV capability. Use of this loophole is particularly common for speculative developers, who aim to build labs as quickly and inexpensively as possible and who would not be paying the utility bills. Removing the 10 ACH threshold avoids this negative consequence.

2.1.2.2 Background Information

The lab VAV requirements in Section 140.9(c)1 were added to Title 24 in 2013 and apply to systems where minimum circulation rates are 10 ACH or less. Existing code requires that lab exhaust be designed so they have variable volume controls on supply and exhaust fans. An exception is provided for laboratory exhaust systems where constant volume is required by code, the authority having jurisdiction (AHJ), or the facility environmental health and safety division [Exception 1 to §140.9(c)1]. Examples include hoods using perchloric acid, hoods with radio isotopes, and exhaust systems conveying dust or vapors that need a minimum velocity for containment.

This proposal would extend the existing VAV requirement to achieve additional savings during unoccupied times. Many existing labs already have lower minimum ventilation requirements when unoccupied, but code does not require systems to reduce ventilation when spaces are unoccupied. With this proposal, if a lab space is allowed to have lower ventilation rates when unoccupied, then code would require the VAV system have the ability to turn down ventilation to those minimum allowable rates.

Though the proposed language indicates occupied airflow rates of 1.0 cfm/ft² and unoccupied airflow rates of 0.67 cfm/ft², this requirement would not mandate those rates specifically as there are allowances where higher rates are required for code, accreditation, or environmental health and safety requirements. This provides flexibility where higher rates may be required, such as based on the results of a hazard

evaluation and risk assessment. In many labs there are no code or accreditation minimums other than the Title 24 ventilation rates (typically 0.15 cfm/ft², which is about 0.9 ACH for a 10-foot ceiling height). Typical industry practice is to design dilution ventilation in laboratories to much higher rates ranging between four and 12 ACH as suggested by laboratory design guidelines and standards.³

The proposal would delete Exception 1, which currently exempts systems that are required to be constant volume by the authority having jurisdiction, environmental health and safety, or code. However, this exception is effectively maintained by allowing the occupied and unoccupied airflow rates to be set based on alternative requirements. If those rates are set to be equal, then a system may still be designed to be constant volume.

The proposal refers to ACH₁₀, which is the ACH assuming a 10-foot ceiling. ACH₁₀ is used, instead of ACH, because it is a more accurate metric for dilution. The reason to have a minimum air change rate is to dilute the airborne concentration of harmful chemicals. For example, if an accident occurs in a lab space and a liter of a particular solution is spilled, the subsequent airborne concentration of that chemical could have adverse health and safety consequences. The airborne concentration is a function of the volume of the space (ft³) and the flow rate of ventilation supply/exhaust to/from the space measured in cubic feet per minute (cfm).

For a given room area (ft²) a higher ceiling provides better dilution than a lower ceiling. ACH is a function of room volume (ft³); that is, area (ft²) times ceiling height (ft). A higher ceiling requires more ventilation flow rate (cfm) for a given ACH rate. Conversely a lower ceiling requires a lower flow rate (cfm) to achieve the same ACH rate. If the metric is in ACH, then a space with a high ceiling will be safer than a space with a low ceiling, even though the ACH rates are the same. Spaces with high ceilings are unfairly penalized by the ACH metric. For example, for a 1,000 square foot room, if the ceiling is 8-feet then 6 ACH requires 0.8 cfm/ft² but if the ceiling is 10-feet then 6 ACH requires 1.0 cfm/ft². The 10-foot ceiling space is already safer than the 8-foot space because it has a higher volume. To be just as safe as the 8-foot space the 10-foot space should have a lower flow rate (cfm/ft²), not a higher flow rate (cfm/ft²).

³ Typical air change rates:

- ANSI Z9.5-2022: Prescriptive rate not appropriate to meet all conditions, but typical rates from 4 to 10 ACH.
- NFPA 45-2019: Typical: 6 ACH occ / 4 ACH unocc, DCV (informative)
- ASHRAE Handbook of Applications 2019: 4 to 12 ACH Occupied used in past
- Stanford: 6 ACH, 4 ACH unoccupied OK with environmental health and safety approval, 3-4 ACH permitted for labs without hazardous materials
- Caltech: 6 ACH, 4 ACH unoccupied, review with environmental health and safety

Other guidelines that use ACH as a requirement have created negative unintended consequences. Designers and owners have installed lower ceilings than they otherwise might install (e.g., 8 feet rather than 9 or 10 feet) because it reduces the ventilation rate and thus the first cost and operational energy cost of the ventilation system. This makes the spaces less safe both because the volume and ventilation rates are lower.

A metric of cfm/ft² is a more accurate than ACH for dilution. It avoids incorrectly penalizing high ceiling spaces and avoids the negative consequence of lowering the ceiling to reduce the ventilation rates (cfm). The downside of using cfm/ft², rather than ACH, is that the dominant industry metric has always been ACH. Those who work in the industry are more comfortable talking in ACH than in cfm/ft².

As discussed in Section 2.2.2, most labs already have lighting controls that can also be sued to control HVAC systems, so the additional control requirements are minimal.

Design conditions for lab ventilation rates are based on the worst-case conditions. For example, all fume hoods are fully open and/or based on the hottest day of the year with all internal heat sources producing the maximum amount of heat. If the worst-case airflow rate is driven by the fume hoods, then the space is considered “hood dominated”. If the worst-case airflow rate is driven by cooling loads, then the space is considered “load dominated”. If, however, the air change ventilation requirements (to comply with code, accreditation, or facility environmental health and safety department requirements) are higher than the maximum hood or load requirements then the space is considered “air change dominated”, and there is no energy benefit to having VAV hoods if same total amount of air is exhausted from the space regardless of the hood being open or not.

Fume hoods can be either constant volume or variable volume. Constant volume hoods have a bypass that allows the same exhaust flow rate when the sash is down as when the sash is up. Variable volume hoods do not have a bypass and the exhaust flow rate varies based on the sash position.

2.1.3 Summary of Proposed Changes to Code Documents

The sections below summarize how the standards, Reference Appendices, Alternative Calculation Method (ACM) Reference Manuals, and compliance documents would be modified by the proposed change.⁴

⁴ Visit [EnergyCodeAce.com](https://www.energycodeace.com) for trainings, tools and resources to help people understand existing code requirements.

2.1.3.1 Specific Purpose and Necessity of Proposed Code Changes

Each proposed change to language in Title 24, Part 6 as well as the reference appendices to Part 6 are described below. See Section 7 of this report for marked-up code language.

Section: 140.9(c)1

Specific Purpose: The specific purpose is to prescriptively require unoccupied air change setback to achieve further savings from VAV systems when spaces are unoccupied. The change would also eliminate the 10 ACH threshold so savings are achieved in all lab spaces and address the unintended consequence of the existing requirements in that some projects overside their systems so they are designed at over 10 ACH to avoid the VAV requirements.

Necessity: These changes are necessary to capture the energy savings from unoccupied setback from all lab spaces.

Section: Nonresidential Appendix 7.16 Lab Exhaust Ventilation System Acceptance Test

Specific Purpose: Establish acceptance test requirements for VAV control function for both occupied and unoccupied modes.

Necessity: These changes are necessary to confirm that the laboratory HVAC system and the controls are operating in accordance with code requirements, the system will adjust ventilation rates correctly, and energy savings will be achieved while maintaining minimum required ventilation rates.

2.1.3.2 Specific Purpose and Necessity of Changes to the Nonresidential ACM Reference Manual

The purpose and necessity of proposed changes to the Nonresidential ACM Reference Manual are described below. See Section 7.4 of this report for the detailed proposed revisions to the text of the ACM Reference Manual.

Section: 5.1.2 System Map

Specific Purpose: Updates the system maps tables to there is full coverage for all lab spaces.

Necessity: This change improves lab space simulations, but is not directly related to any of the proposed code changes presented in this report. The system map does not currently provide full coverage for lab spaces. It needs to be updated improves coverage and the accuracy of simulations. For example, the map covers labs < 15k cfm of exhaust in buildings less than 4 stories and less than 25k ft² but it does not cover labs

< 15k cfm of exhaust in buildings more than 3 stories or more than 25k ft². The proposed mapping fixes this mistake. It also makes the standard design a 4 pipe VAV system where 140.9(c)5 Reheat Limitation would be prescriptively required. Where 140.9(c)5 is not prescriptively required then the standard design for labs is basically unchanged.

Single zone labs are changed from gas heat to heat pump heating which is consistent with the single zone heat pump requirements added to 140.4(a)2 in 2022.

Sections:

Terminal Air Flow, Variable Air Volume (VAV) Air Flow, TERMINAL MINIMUM AIRFLOW;

Zone Exhaust, EXHAUST MINIMUM AIR FLOW RATE, EXHAUST FAN SCHEDULE;

5.7.3 Fan and Duct Systems, EXHAUST FAN CONTROL METHOD;

Appendix 5.4B spreadsheet

Specific Purpose: The specific purpose is to model unoccupied ventilation setback in the Standard Design and to allow unoccupied ventilation setback in the Proposed Design. It includes 2 ACH of unoccupied setback in the standard design. Lab occupancy schedules in Appendix 5.4B would need to update so they are 0.0 values at times expected to be unoccupied late at night and reduced occupancy during weekends. Currently lowest occupancy value is 0.05 in the middle of the night. The 0.05 and the 0.10 values should be set to 0.0

Necessity: These changes are necessary to capture the energy savings from unoccupied setback in the compliance software so projects that use the performance approach are held to an appropriate energy budget based on the revised prescriptive requirements.

2.1.3.3 Summary of Changes to Compliance Documents

Certificates of Compliance

Rather than adding a new compliance form to document unoccupied setback, we suggest the CEC or EnergyCode Ace develop a software tool to allow designers to easily import their lab zone schedules with zone area, occupied ventilation rate, and unoccupied ventilation rate. The software would then calculate the occupied and unoccupied minimum circulation rates. If any occupied rates are above 1.0 cfm/ft² or any unoccupied rates are above 0.67 cfm/ft² then the user would be required to provide supporting documentation for that zone of the relevant code, accreditation, or facility environmental health and safety department requirement that results in a higher rate. Another option is to have users complete a spreadsheet showing the occupied and unoccupied zone minimums meet the 1.0 and 0.67 cfm/ft² thresholds, similar to the

existing ventilation spreadsheets that show compliance for most spaces with the 0.15 cfm/ft² and 15 cfm/ft² thresholds.

Certificates of Installation

No proposed changes.

Certificates of Acceptance

The proposed code change would add a new acceptance test. It is likely that a new form would need to be created.

2.1.4 Regulatory Context

2.1.4.1 Determination of Inconsistency or Incompatibility with Existing State Laws and Regulations

There are some laboratory occupancies that have required ventilation rates that may be higher than the unoccupied 0.67 cfm/ft² (4 ACH) rate in this proposal, such as Group L and Group H-5 (see below from CA Building Code). However, this proposal specifically allows for higher airflow rates when required by code requirements, so this proposal does not conflict with existing regulations.

From California Building Code:

453.4.7.5 Ventilation Rates (Group L Occupancy):

Mechanical exhaust ventilation systems shall provide a minimum ventilation rate of not less than 1 cubic feet per minute per square foot of floor area, or 6 air exchanges per hour, whichever is greater. Systems shall operate continuously at the designed ventilation rate.

[F] 415.11.1.6 Ventilation (Group H-5 Occupancy):

Mechanical exhaust ventilation at the rate of not less than 1 cubic foot per minute per square foot of floor area shall be provided throughout the portions of the fabrication area where HPM are used or stored. The exhaust air duct system of one fabrication area shall not connect to another duct system outside that fabrication area within the building.

[F] 415.11.6.8 Ventilation (Group H-5 Occupancy):

Mechanical exhaust ventilation shall be provided in liquid storage rooms, HPM rooms and gas rooms at the rate of not less than 1 cubic foot per minute per square foot of floor area or six air changes per hour.

2.1.4.2 Duplication or Conflicts with Federal Laws and Regulations

There are no relevant federal laws or regulations.

2.1.4.3 Difference From Existing Model Codes and Industry Standards

Laboratory ventilation rates are largely determined based on industry standards and guidelines rather than code-driven requirements. NFPA 45-2019 indicates that typical rates are 6 ACH occupied and 4 ACH unoccupied (NFPA 2019). ANSI/ASSP Z9.5-2022 notes that rates should be “determined based on hazard evaluation and risk assessment” but provides informative notes that typical rates range from 4 to 10 ACH (ANSI/ASSP 2022). The 2019 ASHRAE Handbook of Applications references precedents for minimum airflow rates of 4 to 12 ACH when the space is occupied (ASHRAE 2019). The Stanford University Laboratory Standard & Design Guide calls for 6 ACH occupied and says that 4 ACH unoccupied is acceptable with environmental health and safety approval and that 3-4 ACH is permitted at all times for labs without hazardous materials. Similarly, Caltech’s lab standard is 6 ACH occupied and 4 ACH unoccupied, subject to review by environmental health and safety.

Cal/OSHA has ventilation requirements fume hood operation (e.g., 70-100 fpm face velocity in section 5154.1), but does not have requirements for room dilution ventilation. CalOSHA section 5191 “Occupational Exposure to Hazardous Chemicals in Laboratories, Appendix A - National Research Council”, includes

Recommendations Concerning Chemical Hygiene in Laboratories (Non-Mandatory)

4. Ventilation

(a) General laboratory ventilation.

(f) Performance. Rate: 4-12 room air changes/hour is normally adequate general ventilation if local exhaust systems such as hoods are used as the primary method of control (194).

2.1.5 Compliance and Enforcement

When developing this proposal, the Statewide CASE Team considered methods to streamline the compliance and enforcement process and how negative impacts on market actors who are involved in the process could be mitigated or reduced. This section describes how to comply with the proposed code change. It also describes the compliance verification process. Appendix E presents how the proposed changes could impact various market actors.

The compliance verification activities related to this measure that need to occur during each phase of the project are described below:

- **Design Phase:** Designers would need to be aware of the code requirements, including the expansion of VAV requirements to systems with over 10 ACH and the minimum allowable ventilation rates for the lab space. The system would need to be designed to comply with code. For example, the design should

include communication between the lighting controls and mechanical controls to communicate occupancy status. The sequences of operation must include separate setpoints for occupied and unoccupied ventilation rates. These setpoints should be adjustable, particularly if the required ventilation rates are not known in the design phase.

- **Permit Application Phase:** No significant changes anticipated as the proposed requirement would expand existing requirements in Section 140.9(c)1.
- **Construction Phase:** No significant changes anticipated. Installation contractors would need to install systems to specifications, which is within their normal operating procedures.
- **Inspection Phase:** There would be a new acceptance test to demonstrating that the zone airflow rate setpoints are reduced when a laboratory space transitions from occupied to unoccupied. For example, the test might include these instructions: “With the hoods closed and the space occupied, observe that the space airflow setpoint and airflow rate is the occupied airflow minimum (e.g., 6 ACH, or lower). Then vacate the space and observe that the space airflow setpoint and airflow rate is the unoccupied airflow minimum (e.g., 4 ACH, or lower).” Acceptance Test Technicians would need to learn the new tests and become familiar with the forms to document compliance.

The Statewide CASE Team does not anticipate significant changes or difficulties in complying with this measure. The minimal changes would occur with HVAC designers who would have to adjust their mechanical drawings and schedules to reflect the new airflow requirements – all other market actors would operate in the same way.

A suggestion to simplify the certificate of compliance. Rather than adding a new compliance form to document unoccupied setback, CEC or EnergyCodeAce could develop a software tool to allow designers to easily import their lab zone schedules with zone area, occupied ventilation rate, and unoccupied ventilation rate. The software would then calculate the occupied and unoccupied minimum circulation rates. If any occupied rates are above 1.0 cfm/ft² or any unoccupied rates are above 0.67 cfm/ft² then the user would be required to provide supporting documentation for that zone of the relevant code, accreditation, or facility environmental health and safety department requirement that results in a higher rate. Another option is to have users complete a spreadsheet showing the occupied and unoccupied zone minimums meet the 1.0 and 0.67 cfm/ft² thresholds, similar to the existing ventilation spreadsheets that show compliance for most spaces with the 0.15 cfm/ft² and 15 cfm/ft² thresholds.

The compliance software would need to be updated so both the Standard Design and Proposed Design account for unoccupied setbacks correctly. Right now, CBECC restricts ventilation method for labs to “fixed” only. The control can cycle between

occupied and unoccupied minimum air change rates when the occupancy schedule is non-zero versus zero. This can also be accomplished with a separate schedule that is calculated based on inputs for minimum occupied and unoccupied. See Appendix C for more information on software enhancements.

2.2 Market Analysis

2.2.1 Current Market Structure

The Statewide CASE Team performed a market analysis with the goals of identifying current technology availability, current product availability, and market trends. It then considered how the proposed unoccupied setback control may impact the market in general as well as individual market actors. Information was gathered about the incremental cost of complying with the proposed measure. Estimates of market size and measure applicability were identified through research and outreach with stakeholders including utility program staff, CEC staff, and a wide range of industry actors. In addition to conducting personalized outreach, the Statewide CASE Team discussed the current market structure and potential market barriers during a public stakeholder meeting that the Statewide CASE Team held on January 31, 2023.

Primary market actors for this measure include VAV manufacturers, HVAC designers, controls contractors, and commissioning agents. Manufacturers build VAV systems compiling the various components such as valves, dampers, coils, and actuators, and HVAC designers determine the ductwork layout that connects an individual VAV system to the air handler and specify the equipment sizes. Controls contractors program the VAV systems to adhere to the requirements of the zone and to connect those actions to the building automation system. Commissioning agents verify that the system is implemented properly adhering to the owner's project requirements.

2.2.2 Technical Feasibility and Market Availability

Unoccupied setback of ventilation in labs is common today but it is not universal. Air change setback has a large and increasing market penetration across a wide range of public and private sector labs, including UC Berkeley, UC Davis, UC Irvine, UC Merced, UC San Diego, Sonoma State, Genentech, Gilead, etc. One reason setback is now common is the basic understanding that the goal of ventilation is to protect occupants from health risks such as chemical spills, and that when labs are unoccupied there are no occupants to protect and no occupants to spill chemicals. The proposal would result in more labs employing unoccupied setback and thus significant energy savings statewide.

Ventilation rates do need to be controlled. Most labs are required to have occupancy sensors or timeclocks to shut off lighting when unoccupied. Section 130.1(c)1 requires

that all “indoor lighting... Shall be controlled with an occupant sensing control, automatic time-switch control, or other control capable of automatically shutting OFF all of the lighting when the space is typically unoccupied”. Based on a survey of Bay Area lighting designers, occupancy sensors for lighting controls are standard practice in lab spaces. In fact, all the lighting designers that the Statewide CASE Team spoke with indicated that occupancy sensors are required in labs.

The lighting designers also indicated that network lighting control systems are also standard practice in lab buildings. With a network lighting control system, the lighting occupancy sensor status can easily be transmitted from the lighting control system to the building automation system via BACnet over IP. Thus no new hardware is required for this measure. One reason labs have network lighting control systems is because lab buildings include space types that require occupant sensing ventilation controls in 120.1(d)5 such as offices, conference rooms, and corridors, and a network lighting control system is effectively required for occupied standby controls. An advantage of making use of the lighting sensors is that if the occupancy sensor fails, the occupants are aware of the sensor failing (no light) whereas it may not be as evident that a dedicated occupancy sensor serving the HVAC system has failed as a reduction in exhaust flow rate may not be as apparent.

As discussed in the Justification section above, some designers are sizing systems larger than is necessary to avoid the existing lab VAV requirements that apply to smaller systems (10 ACH or less). The proposal would remedy this problem by requiring VAV for systems larger than 10 ACH. This measure seeks to reduce energy consumption by addressing language in the code that may have incentivized the use of high constant volume systems in place of VAV systems by designers seeking to minimize first costs without consideration for operating costs.

The measure does not require the use of any new technology, nor does it require implementation of a new combination of existing technologies.

2.2.3 Market Impacts and Economic Assessments

2.2.3.1 Impact on Builders

Builders of residential and commercial structures are directly impacted by many of the measures proposed by the Statewide CASE Team for the 2025 code cycle. It is within the normal practices of these businesses to adjust their building practices to changes in building codes. When necessary, builders engage in continuing education and training to remain compliant with changes to design practices and building codes.

California’s construction industry comprises approximately 93,000 business establishments and 943,000 employees (see Table 2). For 2022, total estimated payroll will be about \$78 billion. Nearly 72,000 of these business establishments and 473,000

employees are engaged in the residential building sector, while another 17,600 establishments and 369,000 employees focus on the commercial sector. The remainder of establishments and employees work in industrial, utilities, infrastructure, and other heavy construction roles (the industrial sector).

Table 2: California Construction Industry, Establishments, Employment, and Payroll in 2022 (Estimated)

Building Type	Construction Sectors	Establishments	Employment	Annual Payroll (Billions \$)
Residential	All	71,889	472,974	31.2
Residential	Building Construction Contractors	27,948	130,580	9.8
Residential	Foundation, Structure, & Building Exterior	7,891	83,575	5.0
Residential	Building Equipment Contractors	18,108	125,559	8.5
Residential	Building Finishing Contractors	17,942	133,260	8.0
Commercial	All	17,621	368,810	35.0
Commercial	Building Construction Contractors	4,919	83,028	9.0
Commercial	Foundation, Structure, & Building Exterior	2,194	59,110	5.0
Commercial	Building Equipment Contractors	6,039	139,442	13.5
Commercial	Building Finishing Contractors	4,469	87,230	7.4
Industrial, Utilities, Infrastructure, & Other (Industrial+)	All	4,206	101,002	11.4
Industrial+	Building Construction	288	3,995	0.4
Industrial+	Utility System Construction	1,761	50,126	5.5
Industrial+	Land Subdivision	907	6,550	1.0
Industrial+	Highway, Street, and Bridge Construction	799	28,726	3.1
Industrial+	Other Heavy Construction	451	11,605	1.4

Source: (State of California n.d.)

The proposed change to lab VAV requirement would likely affect commercial builders but would not impact firms that focus on construction and retrofit of industrial buildings, utility systems, public infrastructure, or other heavy construction. The effects on the commercial building industry would not be felt by all firms and workers, but rather would be concentrated in specific industry subsectors. Table 3 shows the commercial building subsectors the Statewide CASE Team expects to be impacted by the changes proposed in this report. As the measure affects setpoints on the air handling system for occupied and unoccupied configurations, the measure impacts mainly the HVAC contractors. The Statewide CASE Team’s estimates of the magnitude of these impacts are shown in Section 2.2.4 Economic Impacts.

Table 3: Specific Subsectors of the California Commercial Building Industry Impacted by Proposed Change to Code/Standard by Subsector in 2022 (Estimated)

Construction Subsector	Establishments	Employment	Annual Payroll (Billions \$)
Nonresidential plumbing & HVAC contractors	2,346	55,572	5.5

Source: (State of California n.d.)

2.2.3.2 Impact on Building Designers and Energy Consultants

Adjusting design practices to comply with changing building codes is within the normal practices of building designers. Building codes (including Title 24, Part 6) are typically updated on a three-year revision cycle, and building designers and energy consultants engage in continuing education and training to remain compliant with changes to design practices and building codes.

Businesses that focus on residential, commercial, institutional, and industrial building design are contained within the Architectural Services sector (North American Industry Classification System 541310). Table 4 shows the number of establishments, employment, and total annual payroll for Building Architectural Services. The proposed code changes would potentially impact all firms within the Architectural Services sector. The Statewide CASE Team anticipates the impacts for lab VAV requirements to affect firms that focus only on nonresidential construction.

There is not a North American Industry Classification System (NAICS)⁵ code specific to energy consultants. Instead, businesses that focus on consulting related to building energy efficiency are contained in the Building Inspection Services sector (NAICS 541350), which is comprised of firms primarily engaged in the physical inspection of residential and nonresidential buildings.⁶ It is not possible to determine which business establishments within the Building Inspection Services sector are focused on energy

⁵ NAICS is the standard used by federal statistical agencies in classifying business establishments for the purpose of collecting, analyzing, and publishing statistical data related to the U.S. business economy. NAICS was developed jointly by the U.S. Economic Classification Policy Committee (ECPC), Statistics Canada, and Mexico's Instituto Nacional de Estadística y Geografía, to allow for a high level of comparability in business statistics among the North American countries. NAICS replaced the Standard Industrial Classification (SIC) system in 1997.

⁶ Establishments in this sector include businesses primarily engaged in evaluating a building's structure and component systems and includes energy efficiency inspection services and home inspection services. This sector does not include establishments primarily engaged in providing inspections for pests, hazardous wastes or other environmental contaminants, nor does it include state and local government entities that focus on building or energy code compliance/enforcement of building codes and regulations.

efficiency consulting. The information shown in Table 4 provides an upper bound indication of the size of this sector in California.

Energy consultants will need to become familiar with the ACM rule changes as described in section 7.4.

Table 4: California Building Designer and Energy Consultant Sectors in 2022 (Estimated)

Sector	Establishments	Employment	Annual Payroll (Millions \$)
Architectural Services ^a	4,134	31,478	3,623.3
Building Inspection Services ^b	1,035	3,567	280.7

Source: (State of California n.d.)

- a. Architectural Services (NAICS 541310) comprises private-sector establishments primarily engaged in planning and designing residential, institutional, leisure, commercial, and industrial buildings and structures.
- b. Building Inspection Services (NAICS 541350) comprises private-sector establishments primarily engaged in providing building (residential & nonresidential) inspection services encompassing all aspects of the building structure and component systems, including energy efficiency inspection services.

2.2.3.3 Impact on Occupational Safety and Health

The proposed code change does not alter any existing federal, state, or local regulations pertaining to safety and health, including rules enforced by the California Division of Occupational Safety and Health (DOSH). All existing health and safety rules would remain in place. Complying with the proposed code change is not anticipated to have adverse impacts on the safety or health of occupants or those involved with the construction, commissioning, and maintenance of the building.

2.2.3.4 Impact on Building Owners and Occupants

Commercial Buildings

The commercial building sector includes a wide array of building types, including offices, restaurants and lodging, retail, and mixed-use establishments, and warehouses (including refrigerated) (Kenney 2019). Energy use by occupants of commercial buildings also varies considerably, with electricity used primarily for lighting, space cooling and conditioning, and refrigeration, while natural gas is used primarily for water heating and space heating. According to information published in the 2019 California Energy Efficiency Action Plan, there is more than 7.5 billion square feet of commercial floor space in California consuming 19 percent of California’s total annual energy use (Kenney 2019). The diversity of building and business types within this sector creates a challenge for disseminating information on energy and water efficiency solutions, as does the variability in sophistication of building owners and the relationships between

building owners and occupants. Labs can be found in different building types including schools and offices. Furthermore, there is a growing trend of existing office spaces being retrofitted to labs.

Estimating Impacts

Building owners and occupants would benefit from lower energy bills. The proposed measure would allow for lower energy bills without negatively impacting the air quality of the lab spaces, and there are exceptions allowed for health and safety constraints. As discussed in Section 2.2.4.1, when building occupants save on energy bills, they tend to spend it elsewhere in the economy thereby creating jobs and economic growth for the California economy. The Statewide CASE Team does not expect the proposed code change for the 2025 code cycle to impact building owners or occupants adversely.

2.2.3.5 Impact on Building Component Retailers (Including Manufacturers and Distributors)

The Statewide CASE Team anticipates the proposed change would have no material impact on California component retailers.

2.2.3.6 Impact on Building Inspectors

Table 5 shows employment and payroll information for state and local government agencies in which many inspectors of residential and commercial buildings are employed. Building inspectors participate in continuing education and training to stay current on all aspects of building regulations, including energy efficiency. The Statewide CASE Team, therefore, anticipates the proposed change would have no impact on employment of building inspectors or the scope of their role conducting energy efficiency inspections.

Table 5: Employment in California State and Government Agencies with Building Inspectors in 2022 (Estimated)

Sector	Govt.	Establishments	Employment	Annual Payroll (Million \$)
Administration of Housing Programs^a	State	18	265	29.0
	Local	38	3,060	248.6
Urban and Rural Development Admin^b	State	38	764	71.3
	Local	52	2,481	211.5

Source: (State of California, Employment Development Department n.d.)

- a. Administration of Housing Programs (NAICS 925110) comprises government establishments primarily engaged in the administration and planning of housing programs, including building codes and standards, housing authorities, and housing programs, planning, and development.
- b. Urban and Rural Development Administration (NAICS 925120) comprises government establishments primarily engaged in the administration and planning of the development of urban and rural areas. Included in this industry are government zoning boards and commissions.

2.2.3.7 Impact on Statewide Employment

As described in Sections 2.2.3.1 through 2.2.3.6, the Statewide CASE Team does not anticipate significant employment or financial impacts to any particular sector of the California economy. This is not to say that the proposed change would not have modest impacts on employment in California. In Section 2.2.4, the Statewide CASE Team estimated the proposed change in heat recovery would affect statewide employment and economic output directly and indirectly through its impact on builders, designers and energy consultants, and building inspectors. In addition, the Statewide CASE Team estimated how energy savings associated with the proposed change in labs VAV requirement would lead to modest ongoing financial savings for California residents, which would then be available for other economic activities.

2.2.4 Economic Impacts

For the 2025 code cycle, the Statewide CASE Team used the IMPLAN model software,⁷ along with economic information from published sources, and professional judgement to develop estimates of the economic impacts associated with each of the proposed code changes. Conceptually, IMPLAN estimates jobs created as a function of incoming cash flow in different sectors of the economy, due to implementing a code or a standard. The jobs created are typically categorized into direct, indirect, and induced employment. For example, cash flow into a manufacturing plant captures direct employment (jobs created in the manufacturing plant), indirect employment (jobs created in the sectors that provide raw materials to the manufacturing plant) and induced employment (jobs created in the larger economy due to purchasing habits of people newly employed in the manufacturing plant). Eventually, IMPLAN computes the total number of jobs created due to a code. The assumptions of IMPLAN include constant returns to scale, fixed input structure, industry homogeneity, no supply constraints, fixed technology, and constant byproduct coefficients. The model is also static in nature and is a simplification of how jobs are created in the macro-economy.

The economic impacts developed for this report are only estimates and are based on limited and to some extent speculative information. The IMPLAN model provides a relatively simple representation of the California economy and, though the Statewide CASE Team is confident that the direction and approximate magnitude of the estimated economic impacts are reasonable, it is important to understand that the IMPLAN model is a simplification of extremely complex actions and interactions of individual, businesses, and other organizations as they respond to changes in energy efficiency codes. In all aspects of this economic analysis, the CASE Authors rely on conservative

⁷ IMPLAN employs economic data and advanced economic impact modeling to estimate economic impacts for interventions like changes to the California Title 24, Part 6 code. For more information on the IMPLAN modeling process, see www.IMPLAN.com.

assumptions regarding the likely economic benefits associated with the proposed code change. By following this approach, the economic impacts presented below represent lower bound estimates of the actual benefits associated with this proposed code change.

Adoption of this code change proposal would result in relatively modest economic impacts through the additional direct spending by those in the commercial building industry, architects, energy consultants, and building inspectors. The Statewide CASE Team does not anticipate that money saved by commercial building owners or other organizations affected by the proposed 2025 code cycle regulations would result in additional spending by those businesses.

Table 6: Estimated Impact that Adoption of the Proposed Measure Would Have on the California Commercial Construction Sector

Impact Type	Employment	Labor Income	Value Added	Output
Direct Effect	0.3	\$19,737	\$22,810	\$38,850
Indirect Effect	0.1	\$5,376	\$8,437	\$15,537
Induced Effect	0.1	\$7,211	\$12,911	\$20,550
Total Effect	0.4	\$32,325	\$44,157	\$74,936

Source: Statewide CASE Team analysis of data from the IMPLAN modeling software.⁸

Table 7: Estimated Impact that Adoption of the Proposed Measure Would Have on the California Building Designers and Energy Consultants Sectors

Impact Type	Employment	Labor Income	Value Added	Output
Direct Effect	0.0	\$2,375	\$2,352	\$3,717
Indirect Effect	0.0	\$707	\$983	\$1,582
Induced Effect	0.0	\$886	\$1,587	\$2,527
Total Effect	0.0	\$3,969	\$4,922	\$7,826

Source: Statewide CASE Team analysis of data from the IMPLAN modeling software.

Table 8: Estimated Impact that Adoption of the Proposed Measure would have on California Building Inspectors

Impact Type	Employment	Labor Income	Value Added	Output
Direct Effect	0.0	\$242	\$288	\$349
Indirect Effect	0.0	\$22	\$35	\$61
Induced Effect	0.0	\$76	\$137	\$217
Total Effect	0.0	\$341	\$459	\$628

Source: Statewide CASE Team analysis of data from the IMPLAN modeling software.

⁸ IMPLAN® model, 2020 Data, IMPLAN Group LLC, IMPLAN System (data and software), 16905 Northcross Dr., Suite 120, Huntersville, NC 28078 www.IMPLAN.com

2.2.4.1 Creation or Elimination of Jobs

The Statewide CASE Team does not anticipate that the measures proposed for the 2025 code cycle regulation would lead to the creation of new types of jobs or the elimination of existing types of jobs. In other words, the Statewide CASE Team’s proposed change would not result in economic disruption to any sector of the California economy. Rather, the estimates of economic impacts discussed in Section 2.2.4 would lead to modest changes in employment of existing jobs.

2.2.4.2 Creation or Elimination of Businesses in California

As stated in Section 2.2.4.1, the Statewide CASE Team’s proposed unoccupied setback requirement would not result in economic disruption to any sector of the California economy. The proposed change represents a modest change to an HVAC air handling setpoint, which would not excessively burden or competitively disadvantage California businesses – nor would it necessarily lead to a competitive advantage for California businesses. Therefore, the Statewide CASE Team does not foresee any new businesses being created, nor does the Statewide CASE Team think any existing businesses would be eliminated due to the proposed code changes.

2.2.4.3 Competitive Advantages or Disadvantages for Businesses in California

The proposed code changes would apply to all businesses operating labs in California, regardless of whether the business is located inside or outside of the state.⁹ Therefore, the Statewide CASE Team does not anticipate that these measures proposed for the 2025 code cycle regulation would have an adverse effect on the competitiveness of California businesses. The proposed VAV system will allow for long-term savings and present an advantage over the increased capital cost of the system. Likewise, the Statewide CASE Team does not anticipate businesses located outside of California would be advantaged or disadvantaged.

2.2.4.4 Increase or Decrease of Investments in the State of California

The Statewide CASE Team analyzed national data on corporate profits and capital investment by businesses that expand a firm’s capital stock (referred to as net private domestic investment, or NPDI).¹⁰ As Table 9 shows, between 2017 and 2021, NPDI as a percentage of corporate profits ranged from a low of 18 in 2020 due to the worldwide economic slowdowns associated with the COVID 19 pandemic to a high of 35 percent in

⁹ Gov. Code, §§ 11346.3(c)(1)(C), 11346.3(a)(2); 1 CCR § 2003(a)(3) Competitive advantages or disadvantages for California businesses currently doing business in the state.

¹⁰ Net private domestic investment is the total amount of investment in capital by the business sector that is used to expand the capital stock, rather than maintain or replace due to depreciation. Corporate profit is the money left after a corporation pays its expenses.

2019, with an average of 26 percent. While only an approximation of the proportion of business income used for net capital investment, the Statewide CASE Team believes it provides a reasonable estimate of the proportion of proprietor income that would be reinvested by business owners into expanding their capital stock.

Table 9: Net Domestic Private Investment and Corporate Profits, United States (U.S.)

Year	Net Domestic Private Investment by Businesses, Billions of Dollars	Corporate Profits After Taxes, Billions of Dollars	Ratio of Net Private Investment to Corporate Profits (Percent)
2017	518.473	1882.460	28
2018	636.846	1977.478	32
2019	690.865	1952.432	35
2020	343.620	1908.433	18
2021	506.331	2619.977	19
5-Year Average	-	-	26

Source: (Federal Reserve Economic Data (FRED) n.d.)

The Statewide CASE Team does not anticipate that the economic impacts associated with the proposed measure would lead to significant change (increase or decrease) in investment, directly or indirectly, in any affected sectors of California’s economy. Nevertheless, the Statewide CASE Team is able to derive a reasonable estimate of the change in investment by California businesses based on the estimated change in economic activity associated with the proposed measure and its expected effect on proprietor income, which we use a conservative estimate of corporate profits, a portion of which we assume will be allocated to net business investment.¹¹

2.2.4.5 Incentives for Innovation in Products, Materials, or Processes

The proposed measure for labs VAV requirements may drive innovation in more robust sensors and closed loop feedback control systems, as the system is dependent on occupancy sensing to make full use of the proposed VAV setpoints.

2.2.4.6 Effects on the State General Fund, State Special Funds, and Local Governments

The Statewide CASE Team does not expect the proposed code changes would have a measurable impact on California’s General Fund, any state special funds, or local government funds.

¹¹ 26 percent of proprietor income was assumed to be allocated to net business investment; see Table 9.

Cost of Enforcement

Cost to the State: State government already has budget for code development, education, and compliance enforcement. While state government will be allocating resources to update the Title 24, Part 6 Standards, including updating education and compliance materials and responding to questions about the revised requirements, these activities are already covered by existing state budgets. The costs to state government are small when compared to the overall costs savings and policy benefits associated with the code change proposals. The proposed code changes would impact all new construction for labs in state buildings, but our modeling has shown that VAV requirements are cost effective in all climate zones.

Cost to Local Governments: All proposed code changes to Title 24, Part 6 would result in changes to compliance determinations. Local governments would need to train building department staff on the revised Title 24, Part 6 Standards. While this re-training is an expense to local governments, it is not a new cost associated with the 2025 code change cycle. The building code is updated on a triennial basis, and local governments plan and budget for retraining every time the code is updated. There are numerous resources available to local governments to support compliance training that can help mitigate the cost of retraining, including tools, training and resources provided by the IOU Codes and Standards program (such as Energy Code Ace). As noted in Section 2.1.5 and Appendix E, the Statewide CASE Team considered how the proposed code change might impact various market actors involved in the compliance and enforcement process and aimed to minimize negative impacts on local governments.

2.2.4.7 Impacts on Specific Persons

While the objective of any of the Statewide CASE Team's proposal is to promote energy efficiency, the Statewide CASE Team recognizes that there is the potential that a proposed code change may result in unintended consequences. As this measure aims to remove a previously existing loophole and allows for more economical setpoints when high air change rates are not needed, there is no expectation that this measure will have any undue unintended impacts. Refer to Section **Error! Reference source not found.** for more details addressing energy equity and environmental justice.

2.2.5 Fiscal Impacts

2.2.5.1 Mandates on Local Agencies or School Districts

This measure would impact any schools or local agencies that have labs slated for new construction. It would also impact lab additions and alterations of existing labs with variable volume controls.

2.2.5.2 Costs to Local Agencies or School Districts

This measure does not require any new or novel technologies to be implemented but ensures that air change rates are not artificially high to circumvent the previous VAV requirement, and thus there are no significant additional costs expected to local agencies or school districts.

2.2.5.3 Costs or Savings to Any State Agency

Incremental costs are described in section 2.4.3. Energy savings are described in section 2.4.2.

2.2.5.4 Other Non-Discretionary Cost or Savings Imposed on Local Agencies

There are no added non-discretionary costs or savings to local agencies as this would not impact non-discretionary funds.

2.2.5.5 Costs or Savings in Federal Funding to the State

There are no costs or savings to federal funding to the state as this measure does not infringe or otherwise touch upon any federal funds associated with this measure.

2.3 Energy Savings

2.3.1 Energy Savings Methodology

2.3.1.1 Key Assumptions for Energy Savings Analysis

The Statewide CASE Team used EnergyPlus to simulate energy savings of the proposed code change. A baseline and a proposed model were developed from the CEC-approved laboratories prototypes, which is a 3-story building with a total square footage of 53,628 square feet. The building is served by a packaged VAV system with reheat coils at the terminal units. The HVAC system uses DX cooling and hot water from gas fired boiler for heating.

The default rulesets in the 2025 Research Version of CBECC (California Energy Commission n.d.) were used except, the Statewide CASE Team adjusted the CBECC prototype from a three-story building with mixed office and lab spaces to a one-story building with all lab spaces. This was done to focus the savings analysis solely on lab spaces without interactions from other office spaces, as the proposed measures target lab spaces only.

The baseline design, or Standard Design, was also adjusted to set a fixed rate of six air changes per hour at all times, which is typical for lab spaces. The proposed model reduces the outdoor air flow to four air changes per hour during unoccupied hours.

Using EnergyPlus, the Statewide CASE Team simulated hourly energy use for each climate zone. The analysis assessed the potential energy savings of implementing an air change set back measure in a prototypical laboratory space.

For this draft report, impacts were simulated in Climate Zones 2, 3, 7, and 12. The final report will present results from all 16 climate zones, which will provide a more comprehensive view of the potential energy savings and cost effectiveness across the state.

2.3.1.2 Energy Savings Methodology per Prototypical Building

The Statewide CASE Team measured per-unit energy savings expected from the proposed code changes in several ways to quantify key impacts. First, savings are calculated by fuel type. Electricity savings are measured in terms of both energy usage and peak demand reduction. Natural gas savings are quantified in terms of energy usage. Second, the Statewide CASE Team calculated source energy savings. Source energy represents the total amount of raw fuel required to operate a building. In addition to all energy used from on-site production, source energy incorporates all transmission, delivery, and production losses. The hourly source energy values provided by CEC are proportional to GHG emissions. Finally, the Statewide CASE Team calculated Long-Term Systemwide Cost (LSC) savings, formerly known as Time Dependent Value (TDV) Energy Cost Savings. LSC Savings are calculated using hourly energy cost metrics for both electricity and natural gas provided by the CEC. These LSC hourly factors are projected over the 30-year life of the building. The LSC hourly factors incorporate the hourly cost of marginal generation, transmission and distribution, fuel, capacity, losses, and cap-and-trade-based CO2 emissions (California Energy Commission 2022).

The CEC directed the Statewide CASE Team to model the energy impacts using specific prototypical building models that represent typical building geometries for different types of buildings. They also estimate the amount of total existing building stock in 2026, which the Statewide CASE Team used to approximate savings from building alteration (California Energy Commission 2022, California Energy Commission 2022). The prototype buildings that the Statewide CASE Team used in the analysis are presented in Table 10.

Table 10: Prototype Buildings Used for Energy, Demand, Cost, and Environmental Impacts Analysis

Prototype Name	Number of Stories	Floor Area (Square Feet)	Description
Lab Only Single Story	1	17,876	1 story building with 5 zones and a ceiling plenum on each floor. WWR-0.33

The Statewide CASE Team estimated LSC savings, source energy, electricity, natural gas, peak demand, and GHG impacts by simulating the proposed code change in EnergyPlus using prototypical buildings and rulesets from the 2025 Research Version of the California Building Energy Code Compliance (CBECC) software (California Energy Commission n.d.)

CBECC generates two models based on user inputs: the Standard Design and the Proposed Design. The Standard Design represents the geometry of the prototypical building and a design that uses a set of features that result in a LSC energy budget and source energy budget that is minimally compliant with 2022 Title 24, Part 6 code requirements. Features used in the Standard Design are described in the 2022 Nonresidential ACM Reference Manual. The Proposed Design represents the same geometry as the Standard Design, but it assumes the energy features that the software user describes with user inputs. To develop savings estimates for the proposed code changes, the Statewide CASE Team created a Standard Design and Proposed Design for the prototypical building with the Standard Design representing compliance with 2022 code and the Proposed Design representing compliance with the proposed requirements. Comparing the energy impacts of the Standard Design to the Proposed Design reveals the impacts of the proposed code change relative to a building that follows industry typical practices.

The Proposed Design was identical to the Standard Design in all ways except for the revisions that represent the proposed changes to the code. Table 11 presents precisely which parameters were modified and what values were used in the Standard Design and Proposed Design. Specifically, the proposed conditions assume reducing the outside air ventilation to four air changes during unoccupied hours.

Table 11: Modifications Made to Standard Design in Each Prototype to Simulate Proposed Code Change

Prototype ID	Climate Zones	Objects Modified	Parameter Name	Standard Design Parameter Value	Proposed Design Parameter Value
Lab Only Single Story	2, 3, 7, 12	Schedules	Terminal Unit Air Fraction Schedule	6 ACH 24/7	6 ACH during occupied hours, reset to 4 ACH during unoccupied hours

CBECC calculates whole-building energy consumption for every hour of the year measured in kilowatt-hours per year (kWh/yr) and therms per year (therms/yr). It then applies the 2025 LSC hourly factors to calculate LSC energy use in kilo British thermal units per year (kBtu/yr), source energy factors to calculate source energy use in kilo British thermal units per year (kBtu/yr), and hourly GHG emissions factors to calculate

annual GHG emissions (metric tons of carbon dioxide emissions equivalent). CBECC also generates LSC Savings values measured in 2026 present value dollars (2026 PV\$) and nominal dollars. CBECC also calculates annual peak electricity demand measured in kilowatts (kW).

The energy impacts of the proposed code change do vary by climate zone. The Statewide CASE Team simulated the energy impacts in Climate Zones 2, 3, 7, and 12 and applied the climate-zone specific LSC hourly factors when calculating energy and energy cost impacts. The Statewide CASE Team will extend the analysis to include all 16 climate zones in the final draft.

Per-unit energy impacts for nonresidential buildings are presented in savings per square foot. Annual energy, GHG, and peak demand impacts for each prototype building were translated into impacts per square foot by dividing by the floor area of the prototype building. This step allows for an easier comparison of savings across different building types and enables a calculation of statewide savings using the construction forecast that is published in terms of floor area by building type.

2.3.1.3 Statewide Energy Savings Methodology

The per-unit energy impacts were extrapolated to statewide impacts using the statewide construction forecasts that the CEC provided. The statewide construction forecasts estimate new construction/additions that would occur in 2026, the first year that the 2025 Title 24, Part 6 requirements are in effect (California Energy Commission 2022). They also estimate the amount of total existing building stock in 2026, which the Statewide CASE Team used to approximate savings from building alterations. The forecast provides construction (new construction/additions and existing building stock) by building type and climate zone. Appendix A presents additional information about the methodology and assumptions used to calculate statewide energy impacts.

2.3.2 Per-Unit Energy Impacts Results

Energy savings and peak demand reductions per unit are presented in Table 12 for new construction. The per-unit energy savings figures do not account for naturally occurring market adoption or compliance rates.

Table 12: First-Year Energy Impacts Per Square Foot – Unoccupied Setback

Climate Zone	2	3	7	12
First-Year Electricity Savings (kWh)	-0.16	-0.20	0.27	0.07
First-Year Peak Demand Reduction (W)	0.01	0.02	0.07	0.03
First-Year Natural Gas Savings (kBtu)	20.12	16.90	13.37	18.24
First-Year Source Energy Savings (kBtu)	33.2	27.75	22.81	30.15
First-Year LSC Energy Savings (kBtu)	19.55	16.32	16.19	19.63

2.4 Cost and Cost Effectiveness

2.4.1 Energy Cost Savings Methodology

Energy cost savings were calculated by applying the LSC hourly factors to the energy savings estimates that were derived using the methodology described in Section 2.3.1. LSC hourly factors are a normalized metric to calculate energy cost savings that account for the variable cost of electricity and natural gas for each hour of the year, along with how costs are expected to change over the period of analysis. In this case, the period of analysis used is 30 years.

The CEC requested energy cost savings over the 30-year period of analysis in both 2026 present value dollars (2026 PV\$) and nominal dollars. The cost-effectiveness analysis uses energy cost values in 2026 PV\$. Costs and cost effectiveness using and 2026 PV\$ are presented in Section 2.4 of this report. CEC uses results in nominal dollars to complete the Economic and Fiscal Impacts Statement (From 399) for the entire package of proposed change to Title 24, Part 6. Appendix G presents energy cost savings results in nominal dollars.

2.4.2 Energy Cost Savings Results

Per-unit energy cost savings for newly constructed buildings that are realized over the 30-year period of analysis are presented (2026 PV\$) in Table 13 (new construction and additions) and Table 14 (alterations). The LSC hourly factors methodology allows peak electricity savings to be valued more than electricity savings during non-peak periods.

Table 13: 2026 PV LSC Savings Over 30-Year Period of Analysis – Per Square Foot – New Construction– Laboratory

Climate Zone	30-Year LSC Electricity Savings (2026 PV\$)	30-Year LSC Natural Gas Savings (2026 PV\$)	30-Year Total LSC Savings (2026 PV\$)
2	-0.57	20.12	19.55
3	-0.58	16.90	16.32
7	2.82	13.37	16.19
12	1.39	18.24	19.63

Table 14: 2026 PV LSC Savings Over 30-Year Period of Analysis – Per Square Foot – Alterations– Laboratory

Climate Zone	30-Year LSC Electricity Savings (2026 PV\$)	30-Year LSC Natural Gas Savings (2026 PV\$)	30-Year Total LSC Savings (2026 PV\$)
2	-0.57	20.12	19.55
3	-0.58	16.90	16.32
7	2.82	13.37	16.19
12	1.39	18.24	19.63

2.4.3 Incremental First Cost

There are no incremental hardware costs for this measure. While there are no hardware costs, there will be hardware cost savings in some cases. If a lab air handling and exhaust system serves many spaces and the designer accounts for diversity in their calculations, then the systems could potentially be downsized to account for a fraction of the spaces being unoccupied with lower air change rates at design heating or cooling conditions. No hardware cost savings are claimed in this analysis because such savings are difficult to estimate, and the proposal is already cost effective without accounting for hardware cost savings.

The incremental costs include additional programming of the building automation system and additional commissioning to verify that the unoccupied setback is working correctly. The additional programming and commissioning are relatively minor. Based on communications with Bay Area controls contractors and commissioning agents, we conservatively estimate the incremental cost at \$1/ft², based on \$1000 per zone and 1,000 ft²/zone.

2.4.4 Incremental Maintenance and Replacement Costs

There are negligible incremental maintenance costs.

2.4.5 Cost Effectiveness

This proposal would modify the primary prescriptive requirement. As such, a cost analysis is required to demonstrate that the measure is cost effective over the 30-year period of analysis.

The CEC establishes the procedures for calculating cost effectiveness. The Statewide CASE Team collaborated with CEC staff to confirm that the methodology in this report is consistent with their guidelines, including which costs were included in the analysis. The incremental first cost and incremental maintenance costs over the 30-year period of analysis were included. The LSC savings from electricity and natural gas savings were

also included in the evaluation. Design costs were not included nor were the incremental costs of code compliance verification.

According to the CEC’s definitions, a measure is cost effective if the benefit-to-cost (B/C) ratio is greater than 1.0. The B/C ratio is calculated by dividing the cost benefits realized over 30 years by the total incremental costs, which includes maintenance costs for 30 years. The B/C ratio was calculated using 2026 PV costs and cost savings.

Results of the per-unit cost-effectiveness analyses are presented in Table 15 (new construction and additions) and Table 16 (alterations). The proposal saves money over the 30-year period of analysis relative to the existing conditions. The proposed code change is cost effective in Climate Zones 2, 3, 7, and 12 with exceptionally high B/C ratios in all climate zones that were simulated. Again, the Statewide CASE Team will expand the analysis to cover all 16 climate zones in the final report.

Table 15: 30-Year Cost-Effectiveness Summary Per Square Foot – New Construction/Additions

Climate Zone	Benefits LSC Savings + Other PV Savings ^a (2026 PV\$)	Costs Total Incremental PV Costs ^b (2026 PV\$)	Benefit-to-Cost Ratio
2	19.55	1.00	19.55
3	16.32	1.00	16.32
7	16.19	1.00	16.19
12	19.63	1.00	19.63

- a. **Benefits: LSC Savings + Other PV Savings:** Benefits include LSC savings over the period of analysis (California Energy Commission 2022). Other savings are discounted at a real (nominal – inflation) three percent rate. Other PV savings include incremental first-cost savings if proposed first cost is less than current first cost, incremental PV maintenance cost savings if PV of proposed maintenance costs is less than PV of current maintenance costs, and incremental residual value if proposed residual value is greater than current residual value at end of CASE analysis period.
- b. **Costs: Total Incremental Present Valued Costs:** Costs include incremental equipment, replacement, and maintenance costs over the period of analysis. Costs are discounted at a real (inflation-adjusted) three percent rate and if PV of proposed maintenance costs is greater than PV of current maintenance costs. If incremental maintenance cost is negative, it is treated as a positive benefit. If there are no total incremental PV costs, the B/C ratio is infinite.

Table 16: 30-Year Cost-Effectiveness Summary Per Square Foot – Alterations

Climate Zone	Benefits LSC Savings + Other PV Savings ^a (2026 PV\$)	Costs Total Incremental PV Costs ^b (2026 PV\$)	Benefit-to-Cost Ratio
2	19.55	1.00	19.55
3	16.32	1.00	16.32
7	16.19	1.00	16.19
12	19.63	1.00	19.63

- a. **Benefits: LSC Savings + Other PV Savings:** Benefits include LSC Savings over the period of analysis (California Energy Commission 2022). Other savings are discounted at a real (nominal – inflation) three percent rate. Other PV savings include incremental first-cost savings if proposed first cost is less than current first cost, incremental PV maintenance cost savings if PV of proposed maintenance costs is less than PV of current maintenance costs, and incremental residual value if proposed residual value is greater than current residual value at end of CASE analysis period.
- b. **Costs: Total Incremental Present Valued Costs:** Costs include incremental equipment, replacement, and maintenance costs over the period of analysis. Costs are discounted at a real (inflation-adjusted) three percent rate and if PV of proposed maintenance costs is greater than PV of current maintenance costs. If incremental maintenance cost is negative, it is treated as a positive benefit. If there are no total incremental PV costs, the B/C ratio is infinite.

2.5 First-Year Statewide Impacts

The code change proposal would not modify the stringency of the existing California Energy Code, so the savings associated with this proposed change are minimal. Typically, the Statewide CASE Team presents a detailed analysis of statewide energy and cost savings associated with the proposed change in Section 2.5 of the Draft CASE Report. As discussed in Section 2.3, although the energy savings are limited, the measure would promote.

2.5.1 Statewide Energy and Energy Cost Savings

The Statewide CASE Team calculated the first-year statewide savings for new construction and additions by multiplying the per-unit savings, which are presented in Section 2.3.2, by assumptions about the percentage of newly constructed buildings that would be impacted by the proposed code. The statewide new construction forecast for 2026 is presented in Appendix A, as are the Statewide CASE Team’s assumptions about the percentage of new construction that would be impacted by the proposal (by climate zone and building type).

The first-year energy impacts represent the first-year annual savings from all buildings that were completed in 2026. The 30-year energy cost savings represent the energy cost savings over the entire 30-year analysis period. The statewide savings estimates do not take naturally occurring market adoption or compliance rates into account.

The table below presents the first-year statewide energy and energy cost savings from newly constructed buildings (Table 18) by climate zone. The Statewide CASE Team calculated the statewide impacts by multiplying the per-unit energy savings by the 2026 new construction forecast for labs.

This draft report presents results for Climate Zones 2, 3, 7, and 12. The proposal will apply to all climate zones, and results for the remaining climate zones will be presented in the final CASE Report. The statewide savings estimates are underestimated for the draft report because savings from the remaining climate zones are not accounted for yet.

Table 17: Statewide Energy and Energy Cost Impacts – New Construction

Climate Zone	Statewide New Construction and Additions Impacted by Proposed Change in 2026 (Million Square Feet)	First-Year ^a Electricity Savings (GWh)	First-Year Peak Electrical Demand Reduction (MW)	First-Year Natural Gas Savings (Million Therms)	First-Year Source Energy Savings (Million kBtu)	30-Year Present Valued Energy Cost Savings (Million 2026 PV\$)
2	139,677	(0.02)	0.00	0.05	4.64	\$2.73
3	940,564	(0.19)	0.02	0.29	26.10	\$15.35
7	195,234	0.05	0.01	0.05	4.45	\$3.16
12	315,980	0.02	0.01	0.10	9.53	\$6.20

a. First-year savings from all buildings completed statewide in 2026.

Table 18: Statewide Energy and Energy Cost Impacts – Alterations

Climate Zone	Statewide New Construction and Additions Impacted by Proposed Change in 2026 (Million Square Feet)	First-Year ^a Electricity Savings (GWh)	First-Year Peak Electrical Demand Reduction (MW)	First-Year Natural Gas Savings (Million Therms)	First-Year Source Energy Savings (Million kBtu)	30-Year Present Valued Energy Cost Savings (Million 2026 PV\$)
2	291,928	(0.05)	0.00	0.11	9.69	\$5.71
3	2,688,504	(0.55)	0.06	0.82	74.62	\$43.89
7	1,251,432	0.34	0.09	0.31	28.55	\$20.26
12	883,792	0.07	0.03	0.29	26.65	\$17.35

a. First-year savings from all buildings completed statewide in 2026.

2.5.2 Statewide Greenhouse Gas (GHG) Emissions Reductions

The Statewide CASE Team calculated avoided GHG emissions associated with energy consumption using the hourly GHG emissions factors that CEC developed along with the 2025 LSC hourly factors and an assumed cost of \$123.15 per metric ton of carbon dioxide equivalent emissions (metric tons CO₂e).

The 2025 LSC hourly factors used in the lifecycle cost-effectiveness analysis include the monetary value of avoided GHG emissions based on a proxy for permit costs (not social costs).¹² The cost-effectiveness analysis presented in Section 2.4 of this report does not include the cost savings from avoided GHG emissions. To demonstrate the cost savings of avoided GHG emissions, the Statewide CASE Team disaggregated the value of avoided GHG emissions from the other economic impacts. The authors used the same monetary values that are used in the LSC hourly factors.

Table 19 presents the estimated first-year avoided GHG emissions of the proposed code change. During the first year, GHG emissions of 270 metric tons CO₂e would be avoided for the modeled climate zones.

Again, this draft report presents results for Climate Zones 2, 3, 7, and 12. The proposal will apply to all climate zones, and results for the remaining climate zones will be presented in the final CASE Report. The statewide savings estimates are underestimated for the draft report because savings from the remaining climate zones are not accounted for yet.

Table 19: First-Year Statewide GHG Emissions Impacts – Unoccupied Standby

Measure	Electricity Savings ^a (GWh/yr)	Reduced GHG Emissions from Electricity Savings ^a (Metric Tons CO ₂ e)	Natural Gas Savings ^a (Million Therms/yr)	Reduced GHG Emissions from Natural Gas Savings ^a (Metric Tons CO ₂ e)	Total Reduced GHG Emissions ^a (Metric Ton CO ₂ e)	Total Monetary Value of Reduced GHG Emissions ^b (\$)
Unoccupied Setback	-0.33	90	2.02	11,034	11,123	1,369,787

a. First-year savings from all buildings completed statewide in 2026.

b. GHG emissions factors are included in the LSC hourly factors published by CEC.

2.5.3 Statewide Water Use Impacts

The proposed code change will not result in water savings.

2.5.4 Statewide Material Impacts

The proposed code change will not result in material impacts.

¹² The permit cost of carbon is equivalent to the market value of a unit of GHG emissions in the California Cap-and-Trade program, while social cost of carbon is an estimate of the total economic value of damage done per unit of GHG emissions. Social costs tend to be greater than permit costs. See more on the Cap-and-Trade Program on the California Air Resources Board website: <https://ww2.arb.ca.gov/our-work/programs/cap-and-trade-program>.

3. Heat Recovery

3.1 Measure Description

3.1.1 Proposed Code Change

The proposed code change would add a requirement for heat recovery for laboratory exhaust systems. Specifically, it would add a new requirement in Section 140.9(c)6 (Prescriptive Requirements for Laboratories and Factories) requiring exhaust air heat recovery for some labs.

- **Type of change:** Prescriptive
- **Building types impacted:** Buildings with laboratory spaces. Occupancy Classifications that may include laboratory spaces include:
 - Business Group B
 - Educational Group E
 - Laboratories Group L
- **Threshold:** The proposal would apply to new lab buildings with over 10,000 cfm of lab exhaust.
- **Additions/Alterations:** The proposal would not apply to additions or alterations of systems that do not currently have heat recovery. If the addition or alteration is to be served by a new supply and exhaust system, then the proposal would apply.
- **Field Verification / Acceptance Tests:** The existing acceptance tests for demonstrating compliance with the existing exhaust air heat recovery requirements in Section 140.4(q) can be used for lab spaces. The proposal would add labs as one of the space types that must meet exhaust air heat recovery requirements.
- **Compliance Software Updates:** No significant updates would be required to the software, but the existing heat recovery modules would need to be updated so they apply to lab spaces. The Standard Design would need to be updated to include heat recovery for labs, in the same way that it is included in the Standard Design for other space types. The Standard Design heat recovery effectiveness would match the proposed required effectiveness for labs.
- **Newly Regulated System or Technology?** This proposal does not add requirements for a system or technology that was not regulated previously.

3.1.2 Justification and Background Information

3.1.2.1 Justification

Exhaust air heat recovery is common for laboratories because it is highly cost effective. In fact, in many cases it reduces the project first cost in addition to providing annual energy savings. Heat recovery can reduce both the peak cooling load and the peak heating load.

Reducing the peak cooling load allows the cooling equipment to be downsized (e.g., smaller chillers, smaller cooling coils, smaller chilled water pumps, smaller chilled water piping, etc.). Similarly, reducing the peak heating load allows the heating equipment to be downsized (e.g., smaller boilers or heat pumps, smaller heating coils, smaller hot water pumps, smaller hot water pipes, etc.).

3.1.2.2 Background Information

Lab exhaust heat recovery is typically achieved with a coil run-around system, as opposed to a plate-type or wheel-type air-to-air heat exchanger. This is to mitigate the risk of cross-contamination from the exhaust air stream to outside air stream.

With a run-around system a fluid coil (water or glycol) is added into the exhaust airstream (see Figure 1). New pump(s) and piping are added to transfer heat from the exhaust coil to a coil in the supply air handler(s) (see Figure 2). If the supply air handler has an existing heating coil, then that coil can also be used as the heat recovery coil. If the air handler does not have a heating coil, then a recovery coil must be added (see Figure 3).

The control sequences for this type of lab exhaust heat recovery system are typically quite simple. For example:

- Cooling: When the outside air temperature is above 83°F command the lab exhaust heat recovery bypass damper zero percent open and enable the heat recovery pumps at design speed.
- Heating: A PID loop shall maintain the supply air temperature at the minimum SAT setpoint by first modulating the bypass damper from 100 percent to zero percent and then modulating the HW valve from 0 percent to 100 percent. Run the heat recovery pumps at design speed when the bypass damper is less than 100 percent.

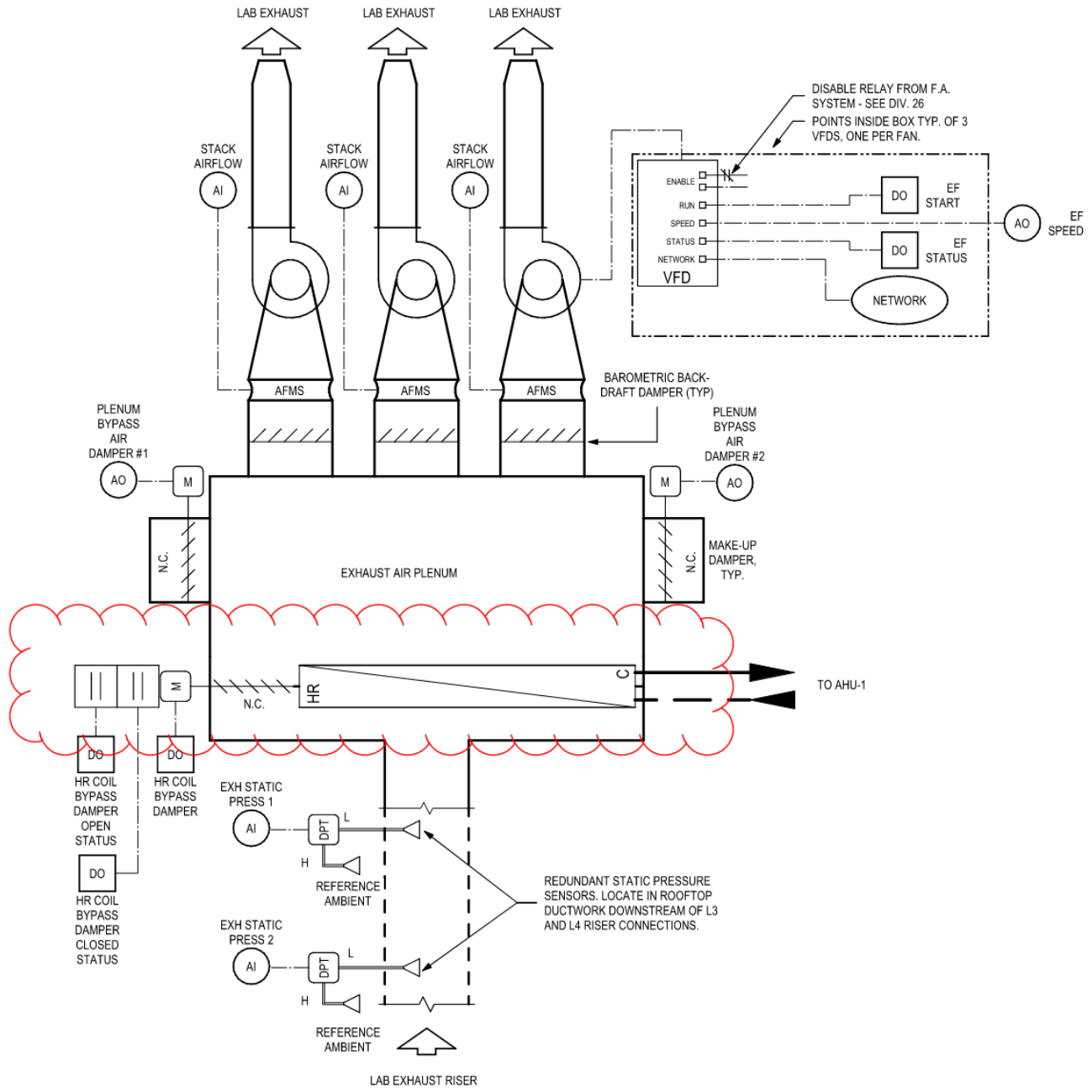

Figure 1: Typical control schematic of lab exhaust fan system with heat recovery coil.

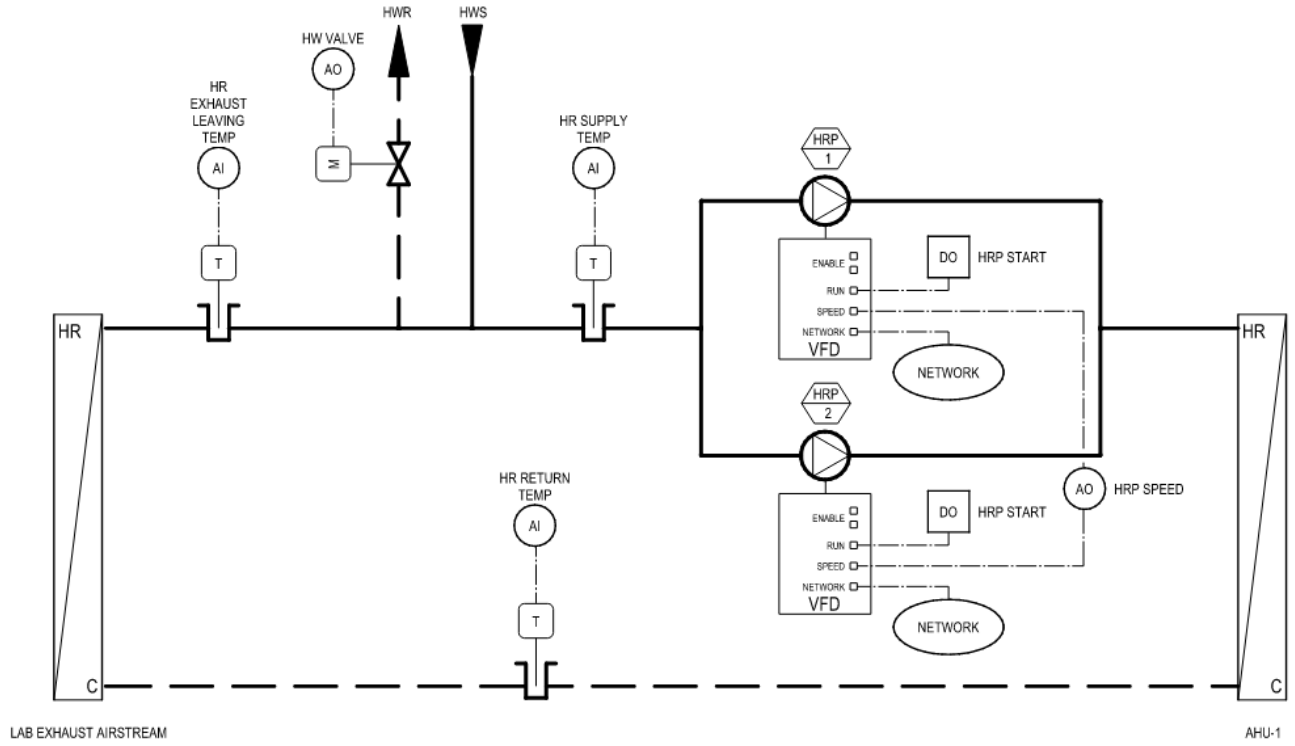

Figure 2: Typical schematic of lab exhaust heat recovery system.

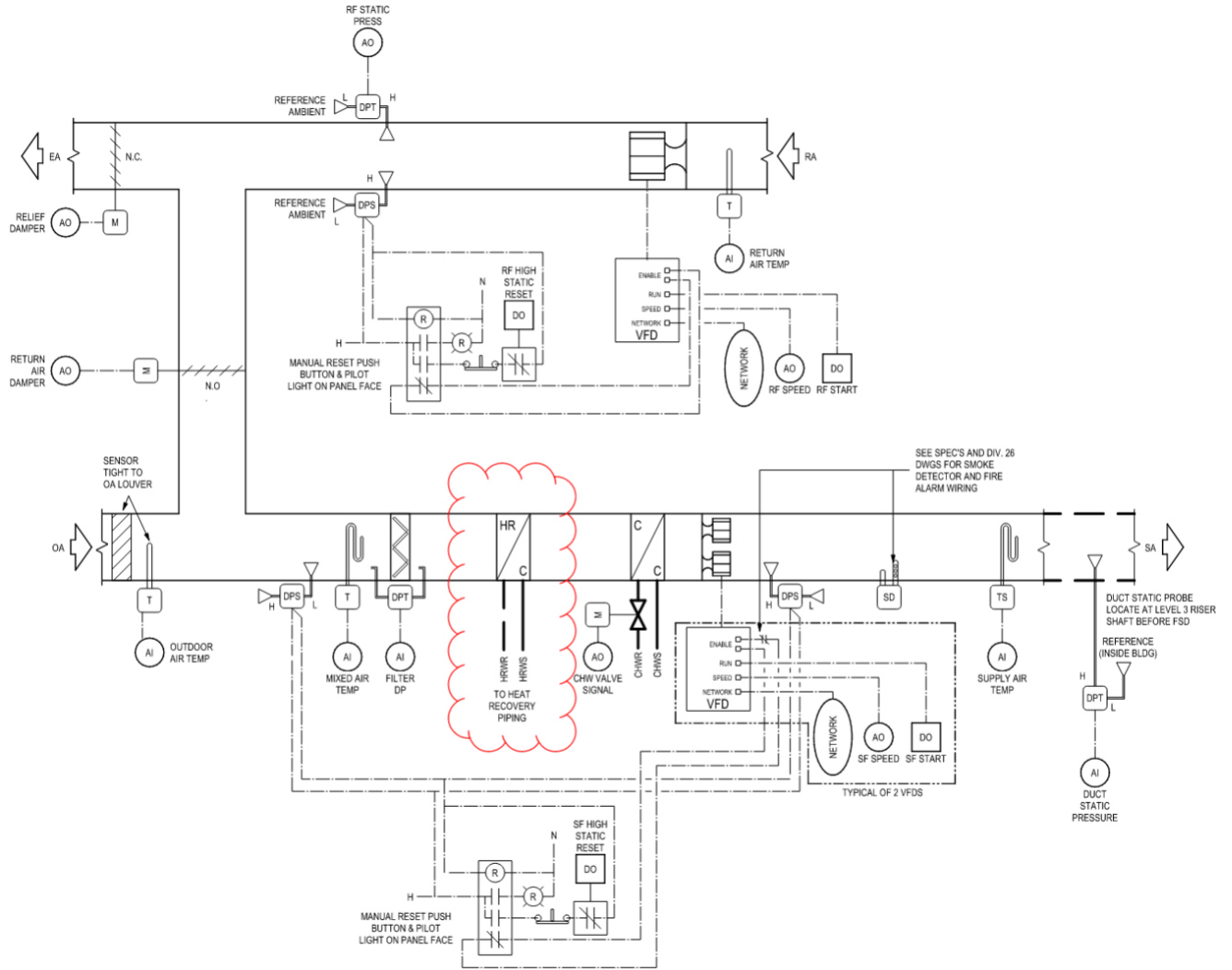

Figure 3: Typical schematic of lab air handler with heat recovery coil.

ASHRAE 90.1 includes a laboratory exhaust air heat recovery requirement that has been unchanged since 2010. The 90.1 requirement basically requires 50 percent effective exhaust air heat recovery or VAV space airflow controls with 50 percent turndown or some equivalent combination of heat recovery and VAV controls.

6.5.7.3 Laboratory Exhaust Systems. *Buildings with laboratory exhaust systems having a total exhaust rate greater than 5000 cfm shall include at least one of the following features:*

- a. *VAV laboratory exhaust and room supply system capable of and configured to reduce exhaust and makeup airflow rates and/or incorporate a heat recovery system to precondition makeup air from laboratory exhaust that shall meet the following:*

$$A + B \times (E/M) \geq 50\%$$

where

A = percentage that the exhaust and makeup airflow rates can be reduced from *design conditions*

B = *sensible energy recovery ratio*

E = exhaust airflow rate through the heat recovery device at *design conditions*

M = makeup airflow rate of the *system* at *design conditions*

- b. *VAV laboratory exhaust and room supply systems that are required to have minimum circulation rates to comply with code or accreditation standards shall be capable of and configured to reduce zone exhaust and makeup airflow rates to the regulated minimum circulation values or the minimum required to maintain pressurization relationship requirements. Systems serving nonregulated zones shall be capable of and configured to reduce exhaust and makeup airflow rates to 50% of the zone design values or the minimum required to maintain pressurization relationship requirements.*
- c. *Direct makeup (auxiliary) air supply equal to at least 75% of the exhaust airflow rate, heated no warmer than 2°F below room set point, cooled to no cooler than 3°F above room set point, no humidification added, and no simultaneous heating and cooling used for dehumidification control.*

Figure 4: ASHRAE 90.1-2022 requirements.

The Statewide CASE Team originally proposed adding the lab VAV requirement for the 2013 code cycle. As part of that effort, the Statewide CASE Team considered the 90.1 tradeoff version and determined that VAV had considerably higher energy savings than heat recovery and therefore recommended requiring VAV and not allow it to be traded off. For this code cycle (ten years later), the Statewide CASE Team has determined that heat recovery is cost effective in addition to VAV controls.

3.1.3 Summary of Proposed Changes to Code Documents

The sections below summarize how the standards, Reference Appendices, Alternative Calculation Method (ACM) Reference Manuals, and compliance documents would be modified by the proposed change.¹³ See Section 7 of this report for detailed proposed revisions to code language.

3.1.3.1 Specific Purpose and Necessity of Proposed Code Changes

Each proposed change to language in Title 24, Part 6 as well as the reference appendices to Part 6 are described below. See Section 7.2 of this report for marked-up code language.

¹³ Visit [EnergyCodeAce.com](https://www.energycodeace.com) for trainings, tools and resources to help people understand existing code requirements.

Section: 140.9(c)6

Specific Purpose: The specific purpose is to require laboratory exhaust air heat recovery for most labs.

Necessity: These changes are necessary to capture the energy savings of laboratory heat recovery. See below for explanations of each part of the proposed language:

- *Buildings with greater than 10,000 cfm of laboratory* – the proposal is limited to systems with at least 10,000 cfm of lab exhaust because cost effectiveness was not evaluated for systems smaller than this.
- *A sensible energy recovery ratio of at least 45 percent at heating design conditions and 25 percent at cooling design conditions* – these minimum recovery ratios were selected based on a review of actual designs in several climates. All the actual designs were well above these ratios.
- *Heat is recovered from at least 75 percent of all lab exhaust air* – this is to avoid the potential loophole of only installing heat recovery on a small fraction of the total exhaust (e.g., on just one of several lab exhaust plenums).
- *The system includes a run-around coil pump or other means to disable heat recovery* – Most, if not all labs will use a run-around system, making this unnecessary, but other systems like plate or wheel heat exchangers are possible. If a plate did not have a bypass or other means to disable it, then it could actually increase not decrease energy use. This avoids that risk. It also gives a bit of design guidance by suggesting run-around systems.
- *The system includes a bypass damper or other means so that the exhaust air pressure drop through the heat exchanger does not exceed 0.4" w.g when heat recovery is disabled* – This is to avoid poor designs that incur high pressure drop penalties (e.g., high velocity coils) even when heat recovery is disabled. This can be achieved with low velocity (oversized) coils or with a coil bypass damper. This also matches 90.1:

6.5.6.1.2.2 Provision for Air Economizer or Bypass Operation. Provision shall be made for both *outdoor air* and exhaust air to bypass or *control* the *energy recovery system* to enable *economizer* operation as required by Section 6.5.1.1. The bypass or *control* shall meet the following criteria:

- a. For *energy recovery systems* where the transfer of *energy* cannot be stopped, bypass provision shall prevent the total airflow rate of either *outdoor air* or exhaust air through the *energy* recovery exchanger from exceeding 10% of the full design airflow rate.
- b. The pressure drop of the *outdoor air* through the *energy* recovery exchanger shall not exceed 0.4 in. of water; the pressure drop of the exhaust air through the *energy* recovery exchanger shall not exceed 0.4 in. of water.

Exception to 6.5.6.1.2.2: *Energy recovery systems* with 80% or more *outdoor air* at full design airflow rate and not exceeding 10,000 cfm.

Exceptions:

- Exception 1 to Section 140.9(c)6: Additions and alterations to existing laboratory exhaust systems that do not include exhaust air heat recovery are exempt because heat recovery cannot be easily added to an existing system that does not have it already.
- Exception 2 to Section 140.9(c)6: was added in response to stakeholder comments. See 3.1.2.2.
- Exception 3 to Section 140.9(c)6: was added because the measure is not cost effective for the gas baseline in these climate zones.
- Exception 4 to Section 140.9(c)6: using the exhaust airstream for heat absorption/rejection by a heat recovery chiller system has similar energy savings to the proposed heat recovery requirement. Figure 5 is a schematic of a lab system with options to recovery heat to both the chiller and AHU or just to the chiller. When heat is recovered just to the chiller a 6-way control valve is used at the heat recovery coil (like the changeover zone coils) so that the heat recovery coil can be used as a heat source (when there is a net heating load) or a heat sink (when there is a net cooling load).

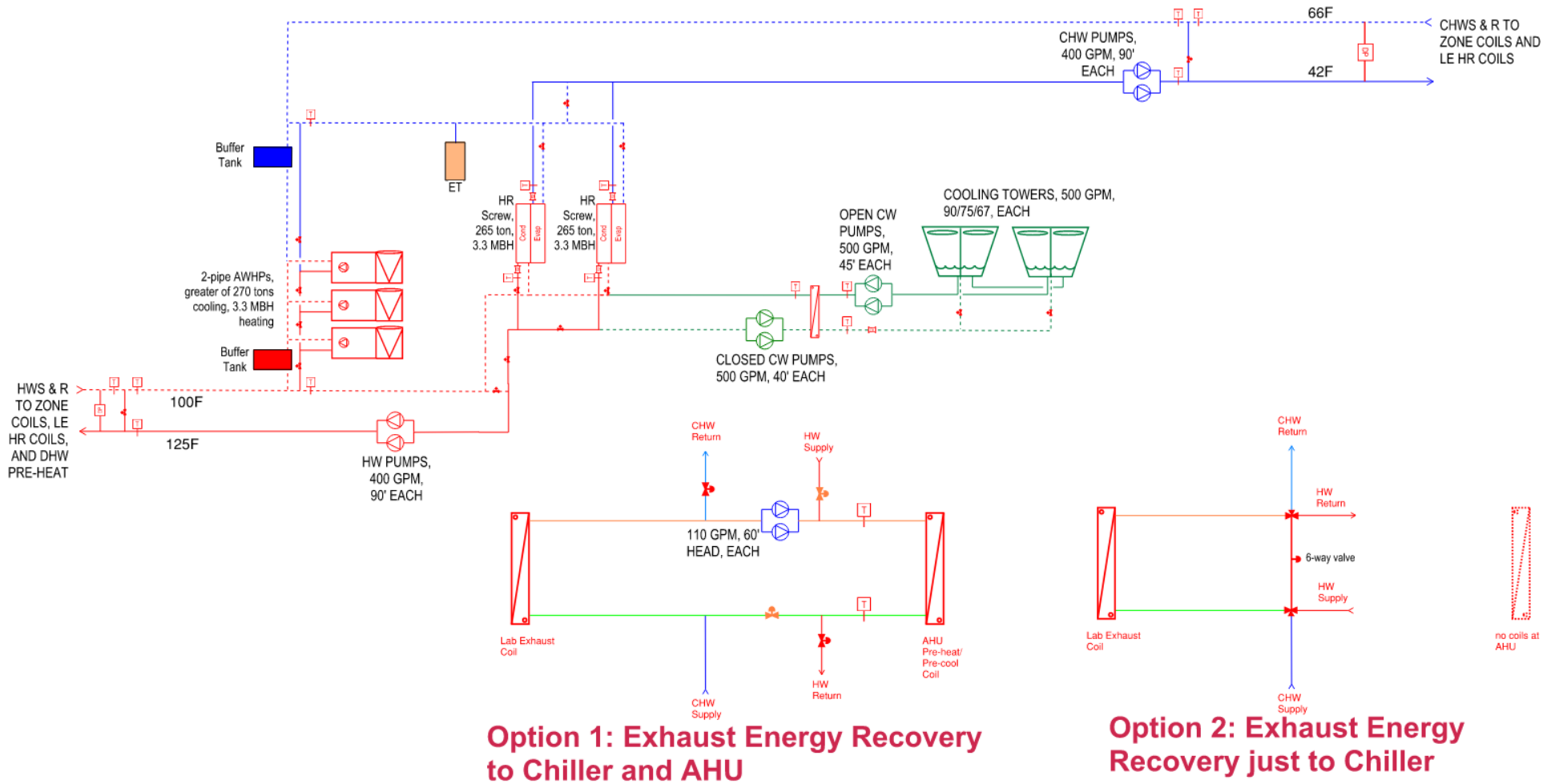

Figure 5. Schematic of lab exhaust to heat recovery chiller.

Section: 141.1(a)

Specific Purpose: The current (2022) wording is unclear. Section 140.9(c) has several requirements including 140.9(c)1,2,3,4. The current wording basically repeats the requirement in 140.9(c)3 and does not clarify if any of 140.9(c)1,2,3,4 actually apply to additions or alterations. The proposed new wording clarifies that requirements (and the new 140.9(c)5) apply to additions and alterations.

Necessity: These changes will simplify the code language and clarify the requirements that apply to additions and alterations.

3.1.3.2 Specific Purpose and Necessity of Changes to the Nonresidential ACM Reference Manual

The purpose and necessity of proposed changes to the Nonresidential ACM Reference Manual are described below. See Section 7.4 of this report for the detailed proposed revisions to the text of the ACM Reference Manual.

The ACM rules would be updated to include laboratory exhaust air heat recovery in the standard design in the same way that other systems are currently required to include heat recovery by 140.4(q) are covered by the ACM.

Section: 5.7.7 Heat Recovery

Specific Purpose: The specific purpose is to ensure that labs prescriptively required to include heat recovery are compared to a standard building that includes heat recovery and that proposed designs that include heat recovery are properly credited in the performance approach.

Necessity: These changes are necessary to capture the energy savings of heat recovery where prescriptively required in the performance approach.

3.1.3.3 Summary of Changes to the Nonresidential Compliance Manual

Minor changes will be required to Section 4.7.2.13.1.2 Exhaust Air Heat Recovery (EAHR) of the Nonresidential Compliance Manual. These changes would clarify that labs are no longer exempt and have slightly different energy recovery ratio requirements.

3.1.3.4 Summary of Changes to Compliance Documents

The proposed code change would not modify the compliance documents.

3.1.4 Regulatory Context

3.1.4.1 *Determination of Inconsistency or Incompatibility with Existing State Laws and Regulations*

Section 140.4(q) in Title 24, Part 6 currently contains requirements for exhaust air heat recovery as a function of climate zone, outdoor air fraction, and design exhaust airflow rate. Exception 1 to Section 140.4(q) excludes laboratory exhaust systems. Labs would remain exempt from the exhaust air heat recovery requirements in Section 140.4(q), but would be covered by the new lab-specific exhaust air heat recovery requirements in Section 140.9(c).

3.1.4.2 *Duplication or Conflicts with Federal Laws and Regulations*

There are no relevant federal laws or regulations.

3.1.4.3 *Difference From Existing Model Codes and Industry Standards*

ASHRAE Standard 90.1-2022 includes exhaust air energy recovery requirements in Section 6.5.6, but laboratory systems are exempted if they comply with requirements in Section 6.5.7.3 (ANSI/ASHRAE/IES 2022). Section 6.5.7.3 requires that laboratory exhaust systems greater than 5,000 cfm include at least one of the following:

1. Minimum airflow turndown or energy recovery performance
2. Airflow turndown capability to minimum required rates

This proposal is different from 90.1-2022 in that this proposal requires airflow turndown for most labs and energy recovery for most labs over 10,000 cfm whereas 90.1 requires airflow turndown or energy recovery for most labs over 5,000 cfm.

3.1.5 Compliance and Enforcement

When developing this proposal, the Statewide CASE Team considered methods to streamline the compliance and enforcement process and how negative impacts on market actors who are involved in the process could be mitigated or reduced. This section describes how to comply with the proposed code change. It also describes the compliance verification process. Appendix E presents how the proposed changes could impact various market actors.

The compliance verification activities related to this measure that need to occur during each phase of the project are described below:

- **Design Phase:** Exhaust air heat recovery (EAHR) is common in laboratory systems. Design steps include heat recovery coil selection and run-around pump selection. These selections are similar to other coil and pump selections that HVAC designers routinely perform. For designers who are not familiar with laboratory EAHR there are resources available, such as ASHRAE Handbook,

I2SL, courses available through the IOUs. Upon request, Taylor Engineers, a member of the Statewide CASE Team, can provide plans and sequences for real projects with EAHR to be included in the compliance manuals, posted on CEC website, or provide through EnergyCodeAce. Existing compliance documents for the existing EAHR requirements in 140.4(q) would be unchanged.

- **Permit Application Phase:** No changes anticipated relative to the existing EAHR requirements in 140.4(q).
- **Construction Phase:** No changes anticipated relative to the existing EAHR requirements in 140.4(q).
- **Inspection Phase:** No changes anticipated relative to the existing EAHR requirements in 140.4(q).

3.2 Market Analysis

3.2.1 Current Market Structure

The Statewide CASE Team performed a market analysis with the goals of identifying current technology availability, current product availability, and market trends. It then considered how the proposed standard may impact the market in general as well as individual market actors. Information was gathered about the incremental cost of complying with the proposed measure. Estimates of market size and measure applicability were identified through research and outreach with stakeholders including utility program staff, CEC staff, and a wide range of industry actors. In addition to conducting personalized outreach, the Statewide CASE Team discussed the current market structure and potential market barriers during a public stakeholder meeting that the Statewide CASE Team held on January 31, 2023.

Heat recovery products and solutions are a well-established technology as there have been requirements in ASHRAE 90.1 since 2004 version of the standards. There are many vendors and manufacturers in this space that have offerings on the market that can comply with our proposed heat recovery measure.

3.2.2 Technical Feasibility and Market Availability

Heat recovery systems are readily available and already commonplace in labs because of their cost effectiveness. Concerns over cross-over contamination from exhaust air infiltrating outside air stream have been addressed by using a coil run-around system. Run-around systems can be retrofitted to existing supply air handling systems, and thus can be made to work with designers and HVAC contractors who have a preferred air handling system.

Coil run-around heat recovery systems will reduce the peak cooling and heating load requirements, allowing for reduced equipment size and allowing for savings throughout the life of the system.

One concern raised by stakeholders is space constraints. Heat recovery coils are typically designed for air velocities around 500 fpm. Without heat recovery coils the exhaust plenum could be designed for velocities of 1000-2000 fpm. Adding an EAHR system can increase the size of the exhaust plenum. These plenums are typically located on the roof, near the exhaust fans. If the building is several stories tall and is packed with high load labs, then there may not be enough roof space to accommodate the larger exhaust plenums. In response to this comment, the Statewide CASE Team surveyed some multi-story labs with EAHR to estimate what the theoretical limit might be. One finding was that in many cases EAHR actually reduced the roof space requirements of the mechanical equipment. This is because EAHR reduces the peak heating and cooling loads. If heating is provided by air-source heat pumps (ASHPs) then fewer/small ASHPs are required on the roof. This reduction in ASHP footprint more than compensated for the increase in exhaust plenum footprint. The most lab dense building surveyed had approximately 20 cfm of lab exhaust per square foot of roof area. This roof was easily able to accommodate EAHR. Recognizing that theoretically there is some point at which lab density could be too high to accommodate EAHR, the Statewide CASE Team conservatively added an exception for lab buildings exceeding 20 cfm of lab exhaust per square foot of roof area.

3.2.3 Market Impacts and Economic Assessments

3.2.3.1 Impact on Builders

Builders of residential and commercial structures are directly impacted by many of the measures proposed by the Statewide CASE Team for the 2025 code cycle. It is within the normal practices of these businesses to adjust their building practices to changes in building codes. When necessary, builders engage in continuing education and training to remain compliant with changes to design practices and building codes.

California's construction industry comprises approximately 93,000 business establishments and 943,000 employees (see Table 20). For 2022, total estimated payroll will be about \$78 billion. Nearly 72,000 of these business establishments and 473,000 employees are engaged in the residential building sector, while another 17,600 establishments and 369,000 employees focus on the commercial sector. The remainder of establishments and employees work in industrial, utilities, infrastructure, and other heavy construction roles (the industrial sector).

Table 20: California Construction Industry, Establishments, Employment, and Payroll in 2022 (Estimated)

Building Type	Construction Sectors	Establishments	Employment	Annual Payroll (Billions \$)
Residential	All	71,889	472,974	31.2
Residential	Building Construction Contractors	27,948	130,580	9.8
Residential	Foundation, Structure, & Building Exterior	7,891	83,575	5.0
Residential	Building Equipment Contractors	18,108	125,559	8.5
Residential	Building Finishing Contractors	17,942	133,260	8.0
Commercial	All	17,621	368,810	35.0
Commercial	Building Construction Contractors	4,919	83,028	9.0
Commercial	Foundation, Structure, & Building Exterior	2,194	59,110	5.0
Commercial	Building Equipment Contractors	6,039	139,442	13.5
Commercial	Building Finishing Contractors	4,469	87,230	7.4
Industrial, Utilities, Infrastructure, & Other (Industrial+)	All	4,206	101,002	11.4
Industrial+	Building Construction	288	3,995	0.4
Industrial+	Utility System Construction	1,761	50,126	5.5
Industrial+	Land Subdivision	907	6,550	1.0
Industrial+	Highway, Street, and Bridge Construction	799	28,726	3.1
Industrial+	Other Heavy Construction	451	11,605	1.4

Source: (State of California n.d.)

The proposed change to heat recovery would likely affect commercial builders but would not impact firms that focus on construction and retrofit of industrial buildings, utility systems, public infrastructure, or other heavy construction. The effects on the commercial building industry would not be felt by all firms and workers, but rather would be concentrated in specific industry subsectors. Table 21 shows the commercial building subsectors the Statewide CASE Team expects to be impacted by the changes proposed in this report. Heat recovery would impact only the HVAC contractors, as it is a modification of air handling systems. The Statewide CASE Team’s estimates of the magnitude of these impacts are shown in Section 2.2.4 Economic Impacts.

Table 21: Specific Subsectors of the California Commercial Building Industry Impacted by Proposed Change to Code/Standard by Subsector in 2022 (Estimated)

Construction Subsector	Establishments	Employment	Annual Payroll (Billions \$)
Nonresidential plumbing & HVAC contractors	2,346	55,572	5.5

Source: (State of California n.d.)

3.2.3.2 Impact on Building Designers and Energy Consultants

Adjusting design practices to comply with changing building codes is within the normal practices of building designers. Building codes (including Title 24, Part 6) are typically updated on a three-year revision cycle, and building designers and energy consultants engage in continuing education and training to remain compliant with changes to design practices and building codes.

Businesses that focus on residential, commercial, institutional, and industrial building design are contained within the Architectural Services sector (North American Industry Classification System 541310). Table 4 shows the number of establishments, employment, and total annual payroll for Building Architectural Services. The proposed code changes would potentially impact all firms within the Architectural Services sector. The Statewide CASE Team anticipates the impacts for heat recovery to affect firms that focus on nonresidential construction.

There is not a North American Industry Classification System (NAICS)¹⁴ code specific to energy consultants. Instead, businesses that focus on consulting related to building energy efficiency are contained in the Building Inspection Services sector (NAICS 541350), which is comprised of firms primarily engaged in the physical inspection of residential and nonresidential buildings.¹⁵ It is not possible to determine which business establishments within the Building Inspection Services sector are focused on energy efficiency consulting. The information shown in Table 22 provides an upper bound indication of the size of this sector in California.

¹⁴ NAICS is the standard used by federal statistical agencies in classifying business establishments for the purpose of collecting, analyzing, and publishing statistical data related to the U.S. business economy. NAICS was developed jointly by the U.S. Economic Classification Policy Committee (ECPC), Statistics Canada, and Mexico's Instituto Nacional de Estadística y Geografía, to allow for a high level of comparability in business statistics among the North American countries. NAICS replaced the Standard Industrial Classification (SIC) system in 1997.

¹⁵ Establishments in this sector include businesses primarily engaged in evaluating a building's structure and component systems and includes energy efficiency inspection services and home inspection services. This sector does not include establishments primarily engaged in providing inspections for pests, hazardous wastes or other environmental contaminants, nor does it include state and local government entities that focus on building or energy code compliance/enforcement of building codes and regulations.

Table 22: California Building Designer and Energy Consultant Sectors in 2022 (Estimated)

Sector	Establishments	Employment	Annual Payroll (Millions \$)
Architectural Services^a	4,134	31,478	3,623.3
Building Inspection Services^b	1,035	3,567	280.7

Source: (State of California n.d.)

- a. Architectural Services (NAICS 541310) comprises private-sector establishments primarily engaged in planning and designing residential, institutional, leisure, commercial, and industrial buildings and structures.
- b. Building Inspection Services (NAICS 541350) comprises private-sector establishments primarily engaged in providing building (residential & nonresidential) inspection services encompassing all aspects of the building structure and component systems, including energy efficiency inspection services.

3.2.3.3 Impact on Occupational Safety and Health

The proposed code change does not alter any existing federal, state, or local regulations pertaining to safety and health, including rules enforced by the California Division of Occupational Safety and Health (DOSH). All existing health and safety rules would remain in place. Complying with the proposed code change is not anticipated to have adverse impacts on the safety or health of occupants or those involved with the construction, commissioning, and maintenance of the building.

3.2.3.4 Impact on Building Owners and Occupants

Estimating Impacts

Building owners and occupants would benefit from lower energy bills. As discussed in Section 2.2.4.1, when building occupants save on energy bills, they tend to spend it elsewhere in the economy thereby creating jobs and economic growth for the California economy. The Statewide CASE Team does not expect the proposed code change for the 2025 code cycle to impact building owners or occupants adversely.

3.2.3.5 Impact on Building Component Retailers (Including Manufacturers and Distributors)

The Statewide CASE Team anticipates the proposed change would have no material impact on California component retailers.

3.2.3.6 Impact on Building Inspectors

Table 23 shows employment and payroll information for state and local government agencies in which many inspectors of residential and commercial buildings are employed. Building inspectors participate in continuing education and training to stay current on all aspects of building regulations, including energy efficiency. The Statewide CASE Team, therefore, anticipates the proposed change would have no impact on

employment of building inspectors or the scope of their role conducting energy efficiency inspections.

Table 23: Employment in California State and Government Agencies with Building Inspectors in 2022 (Estimated)

Sector	Govt.	Establishments	Employment	Annual Payroll (Million \$)
Administration of Housing Programs ^a	State	18	265	29.0
	Local	38	3,060	248.6
Urban and Rural Development Admin ^b	State	38	764	71.3
	Local	52	2,481	211.5

Source: (State of California, Employment Development Department n.d.)

- a. Administration of Housing Programs (NAICS 925110) comprises government establishments primarily engaged in the administration and planning of housing programs, including building codes and standards, housing authorities, and housing programs, planning, and development.
- b. Urban and Rural Development Administration (NAICS 925120) comprises government establishments primarily engaged in the administration and planning of the development of urban and rural areas. Included in this industry are government zoning boards and commissions.

3.2.3.7 Impact on Statewide Employment

As described in Sections 2.2.3.1 through 2.2.3.6, the Statewide CASE Team does not anticipate significant employment or financial impacts to any particular sector of the California economy. This is not to say that the proposed change would not have modest impacts on employment in California. In Section 2.2.4, the Statewide CASE Team estimated the proposed change in heat recovery would affect statewide employment and economic output directly and indirectly through its impact on builders, designers and energy consultants, and building inspectors. In addition, the Statewide CASE Team estimated how energy savings associated with the proposed change in heat recovery would lead to modest ongoing financial savings for California residents, which would then be available for other economic activities.

3.2.4 Economic Impacts

For the 2025 code cycle, the Statewide CASE Team used the IMPLAN model software,¹⁶ along with economic information from published sources, and professional judgement to develop estimates of the economic impacts associated with each of the proposed code changes. Conceptually, IMPLAN estimates jobs created as a function of incoming cash flow in different sectors of the economy, due to implementing a code or a standard. The jobs created are typically categorized into direct, indirect, and induced

¹⁶ IMPLAN employs economic data and advanced economic impact modeling to estimate economic impacts for interventions like changes to the California Title 24, Part 6 code. For more information on the IMPLAN modeling process, see www.IMPLAN.com.

employment. For example, cash flow into a manufacturing plant captures direct employment (jobs created in the manufacturing plant), indirect employment (jobs created in the sectors that provide raw materials to the manufacturing plant) and induced employment (jobs created in the larger economy due to purchasing habits of people newly employed in the manufacturing plant). Eventually, IMPLAN computes the total number of jobs created due to a code. The assumptions of IMPLAN include constant returns to scale, fixed input structure, industry homogeneity, no supply constraints, fixed technology, and constant byproduct coefficients. The model is also static in nature and is a simplification of how jobs are created in the macro-economy.

The economic impacts developed for this report are only estimates and are based on limited and to some extent speculative information. The IMPLAN model provides a relatively simple representation of the California economy and, though the Statewide CASE Team is confident that the direction and approximate magnitude of the estimated economic impacts are reasonable, it is important to understand that the IMPLAN model is a simplification of extremely complex actions and interactions of individual, businesses, and other organizations as they respond to changes in energy efficiency codes. In all aspects of this economic analysis, the CASE Authors rely on conservative assumptions regarding the likely economic benefits associated with the proposed code change. By following this approach, the economic impacts presented below represent lower bound estimates of the actual benefits associated with this proposed code change.

Adoption of this code change proposal would result in relatively modest economic impacts through the additional direct spending by those in the commercial building industry, architects, energy consultants, and building inspectors. The Statewide CASE Team does not anticipate that money saved by commercial building owners or other organizations affected by the proposed 2025 code cycle regulations would result in additional spending by those businesses.

Table 24: Estimated Impact that Adoption of the Proposed Measure would have on the California Commercial Construction Sector

Impact Type	Employment	Labor Income	Value Added	Output
Direct Effect	0.3	\$26,465	\$30,585	\$52,093
Indirect Effect	0.1	\$7,209	\$11,313	\$20,833
Induced Effect	0.1	\$9,669	\$17,312	\$27,555
Total Effect	0.6	\$43,344	\$59,210	\$100,481

Source: Statewide CASE Team analysis of data from the IMPLAN modeling software.¹⁷

¹⁷ IMPLAN® model, 2020 Data, IMPLAN Group LLC, IMPLAN System (data and software), 16905 Northcross Dr., Suite 120, Huntersville, NC 28078 www.IMPLAN.com

Table 25: Estimated Impact that Adoption of the Proposed Measure would have on the California Building Designers and Energy Consultants Sectors

Impact Type	Employment	Labor Income	Value Added	Output
Direct Effect	0.2	\$19,004	\$18,813	\$29,736
Indirect Effect	0.1	\$5,658	\$7,864	\$12,659
Induced Effect	0.1	\$7,091	\$12,699	\$20,213
Total Effect	0.3	\$31,754	\$39,377	\$62,609

Source: Statewide CASE Team analysis of data from the IMPLAN modeling software.

Table 26: Estimated Impact that Adoption of the Proposed Measure would have on California Building Inspectors

Impact Type	Employment	Labor Income	Value Added	Output
Direct Effect	0.0	\$485	\$575	\$699
Indirect Effect	0.0	\$45	\$70	\$122
Induced Effect	0.0	\$153	\$273	\$435
Total Effect	0.0	\$682	\$918	\$1,255

Source: Statewide CASE Team analysis of data from the IMPLAN modeling software.

3.2.4.1 Creation or Elimination of Jobs

The Statewide CASE Team does not anticipate that the measures proposed for the 2025 code cycle regulation would lead to the creation of new types of jobs or the elimination of existing types of jobs. In other words, the Statewide CASE Team’s proposed change would not result in economic disruption to any sector of the California economy. Rather, the estimates of economic impacts discussed in Section 2.2.4 would lead to modest changes in employment of existing jobs.

3.2.4.2 Creation or Elimination of Businesses in California

As stated in Section 2.2.4.1, the Statewide CASE Team’s proposed change would not result in economic disruption to any sector of the California economy. The proposed change represents a modest change to requiring a coil run-around heat recovery system which would not excessively burden or competitively disadvantage California businesses – nor would it necessarily lead to a competitive advantage for California businesses. Therefore, the Statewide CASE Team does not foresee any new businesses being created, nor does the Statewide CASE Team think any existing businesses would be eliminated due to the proposed code changes.

3.2.4.3 Competitive Advantages or Disadvantages for Businesses in California

The proposed code changes would apply to all businesses incorporated in California, regardless of whether the business is located inside or outside of the state.¹⁸ Therefore, the Statewide CASE Team does not anticipate that these measures proposed for the 2025 code cycle regulation would have an adverse effect on the competitiveness of California businesses. Likewise, the Statewide CASE Team does not anticipate businesses located outside of California would be advantaged or disadvantaged.

3.2.4.4 Increase or Decrease of Investments in the State of California

The Statewide CASE Team analyzed national data on corporate profits and capital investment by businesses that expand a firm’s capital stock (referred to as net private domestic investment, or NPDI).¹⁹ As Table 9 shows, between 2017 and 2021, NPDI as a percentage of corporate profits ranged from a low of 18 in 2020 due to the worldwide economic slowdowns associated with the COVID 19 pandemic to a high of 35 percent in 2019, with an average of 26 percent. While only an approximation of the proportion of business income used for net capital investment, the Statewide CASE Team believes it provides a reasonable estimate of the proportion of proprietor income that would be reinvested by business owners into expanding their capital stock.

Table 27: Net Domestic Private Investment and Corporate Profits, U.S.

Year	Net Domestic Private Investment by Businesses, Billions of Dollars	Corporate Profits After Taxes, Billions of Dollars	Ratio of Net Private Investment to Corporate Profits (Percent)
2017	518.473	1882.460	28
2018	636.846	1977.478	32
2019	690.865	1952.432	35
2020	343.620	1908.433	18
2021	506.331	2619.977	19
5-Year Average	-	-	26

Source: (Federal Reserve Economic Data (FRED) n.d.)

The Statewide CASE Team does not anticipate that the economic impacts associated with the proposed measure would lead to significant change (increase or decrease) in investment, directly or indirectly, in any affected sectors of California’s economy. Nevertheless, the Statewide CASE Team is able to derive a reasonable estimate of the

¹⁸ Gov. Code, §§ 11346.3(c)(1)(C), 11346.3(a)(2); 1 CCR § 2003(a)(3) Competitive advantages or disadvantages for California businesses currently doing business in the state.

¹⁹ Net private domestic investment is the total amount of investment in capital by the business sector that is used to expand the capital stock, rather than maintain or replace due to depreciation. Corporate profit is the money left after a corporation pays its expenses.

change in investment by California businesses based on the estimated change in economic activity associated with the proposed measure and its expected effect on proprietor income, which the Statewide CASE Team uses a conservative estimate of corporate profits, a portion of which the Statewide CASE Team assumes will be allocated to net business investment.²⁰

3.2.4.5 Incentives for Innovation in Products, Materials, or Processes

The Statewide CASE Team does not expect this measure would have a measure impact on innovation in products, materials, or processes.

3.2.4.6 Effects on the State General Fund, State Special Funds, and Local Governments

The Statewide CASE Team does not expect the proposed code changes would have a measurable impact on California's General Fund, any state special funds, or local government funds.

Cost of Enforcement

Cost to the State: State government already has budget for code development, education, and compliance enforcement. While state government will be allocating resources to update the Title 24, Part 6 Standards, including updating education and compliance materials and responding to questions about the revised requirements, these activities are already covered by existing state budgets. The costs to state government are small when compared to the overall costs savings and policy benefits associated with the code change proposals. Heat recovery systems are already in use in a number of labs due to being highly cost effective.

Cost to Local Governments: All proposed code changes to Title 24, Part 6 would result in changes to compliance determinations. Local governments would need to train building department staff on the revised Title 24, Part 6 Standards. While this re-training is an expense to local governments, it is not a new cost associated with the 2025 code change cycle. The building code is updated on a triennial basis, and local governments plan and budget for retraining every time the code is updated. There are numerous resources available to local governments to support compliance training that can help mitigate the cost of retraining, including tools, training and resources provided by the IOU Codes and Standards program (such as Energy Code Ace). As noted in Section 2.1.5 and Appendix E, the Statewide CASE Team considered how the proposed code change might impact various market actors involved in the compliance and enforcement process and aimed to minimize negative impacts on local governments.

²⁰ 26 percent of proprietor income was assumed to be allocated to net business investment; see Table 9.

3.2.4.7 Impacts on Specific Persons

While the objective of any of the Statewide CASE Team’s proposal is to promote energy efficiency, the Statewide CASE Team recognizes that there is the potential that a proposed code change may result in unintended consequences. This measure seeks to put as a requirement a system that is already being adopted due to its cost effectiveness, and thus the Statewide CASE Team does not see any negative impacts to any group or people. Refer to Section **Error! Reference source not found.** for more details addressing energy equity and environmental justice.

3.2.5 Fiscal Impacts

3.2.5.1 Mandates on Local Agencies or School Districts

This measure would impact any schools or local agencies that have labs slated for new construction.

3.2.5.2 Costs to Local Agencies or School Districts

This measure does not require any new or novel technologies to be implemented but requires existing technology be used to reduce energy consumption, which in turn will reduce operating costs.

3.2.5.3 Costs or Savings to Any State Agency

The cost and savings for lab spaces owned by state agencies will be the same as the costs and savings for other lab owners. These are described in section 3.4.

3.2.5.4 Other Non-Discretionary Cost or Savings Imposed on Local Agencies

There are no added non-discretionary costs or savings to local agencies as this would not impact non-discretionary funds.

3.2.5.5 Costs or Savings in Federal Funding to the State

There are no costs or savings to federal funding to the state as this measure does not infringe or otherwise touch upon any federal funds associated with this measure.

3.3 Energy Savings

3.3.1 Energy Savings Methodology

3.3.1.1 Key Assumptions for Energy Savings Analysis

The analysis assessed the estimated energy savings of the proposed heat recovery requirements using the 2025 CBECC lab prototype provided by the CEC. The prototype

was adjusted to reflect a one-story building with five lab zones, four perimeter zones, and one core zone. EnergyPlus was used to conduct the energy simulation.

The HVAC baseline system is a PVAV utilizing DX for cooling and hot water from a gas boiler for heating. To simulate the proposed case, a heat recovery object was added to the exhaust air stream in the model. The heat recovery object has a sensible heat effectiveness of 0.45 at 100 percent heating air flow and 0.55 at 75 percent heating air flow, and sensible heat effectiveness of 0.25 at 100 percent cooling air flow and 0.35 at 75 percent cooling air flow. The electric consumption of the heat recovery device was also accounted for under auxiliary power based on 0.02 watt per cubic feet per minute (cfm).

For this draft report, the Statewide CASE Team conducted analyses in Climate Zones 2, 3, 7, and 12. These climate zones represent the range of climates in California. The analysis will be expanded for the final report to include all of California's 16 climate zones, which will provide a more comprehensive view of the potential energy savings of the proposed measure in different regions of the state.

3.3.1.2 Energy Savings Methodology per Prototypical Building

The Statewide CASE Team measured per-unit energy savings expected from the proposed code changes in several ways to quantify key impacts. First, savings are calculated by fuel type. Electricity savings are measured in terms of both energy usage and peak demand reduction. Natural gas savings are quantified in terms of energy usage. Second, the Statewide CASE Team calculated source energy Savings. Source energy represents the total amount of raw fuel required to operate a building. In addition to all energy used from on-site production, source energy incorporates all transmission, delivery, and production losses. The hourly source energy values provided by CEC are proportional to GHG emissions. Finally, the Statewide CASE Team calculated Long-term Systemwide Cost (LSC) savings, formerly known as Time Dependent Value (TDV) energy cost savings. LSC Savings are calculated using hourly energy cost metrics for both electricity and natural gas provided by the CEC. These LSC hourly factors are projected over the 30-year life of the building. The LSC hourly factors incorporate the hourly cost of marginal generation, transmission and distribution, fuel, capacity, losses, and cap-and-trade-based CO₂ emissions (California Energy Commission 2022).

The CEC directed the Statewide CASE Team to model the energy impacts using specific prototypical building models that represent typical building geometries for different types of buildings. They also estimate the amount of total existing building stock in 2026, which the Statewide CASE Team used to approximate savings from building alteration (California Energy Commission 2022, California Energy Commission 2022). The prototype buildings that the Statewide CASE Team used in the analysis are presented in Table 10.

Table 28: Prototype Buildings Used for Energy, Demand, Cost, and Environmental Impacts Analysis

Prototype Name	Number of Stories	Floor Area (Square Feet)	Description
Lab Only Single Story	1	17,876	One story office building with 5 zones and a ceiling plenum on each floor. WWR-0.33

The Statewide CASE Team estimated lifecycle energy, source energy, electricity, natural gas, peak demand, and GHG impacts by simulating the proposed code change in EnergyPlus using prototypical buildings and rulesets from the 2025 Research Version of the California Building Energy Code Compliance (CBECC) software (California Energy Commission n.d.).

CBECC generates two models based on user inputs: the Standard Design and the Proposed Design. The Standard Design represents the geometry of the prototypical building and a design that uses a set of features that result in a Lifecycle energy budget and Source energy budget that is minimally compliant with 2022 Title 24, Part 6 code requirements. Features used in the Standard Design are described in the 2022 Nonresidential ACM Reference Manual. The Proposed Design represents the same geometry as the Standard Design, but it assumes the energy features that the software user describes with user inputs. To develop savings estimates for the proposed code changes, the Statewide CASE Team created a Standard Design and Proposed Design for each prototypical building with the Standard Design representing compliance with 2022 code and the Proposed Design representing compliance with the proposed requirements. Comparing the energy impacts of the Standard Design to the Proposed Design reveals the impacts of the proposed code change relative to a building that is minimally compliant with the that follows industry typical practices.

The Proposed Design was identical to the Standard Design in all ways except for the revisions that represent the proposed changes to the code. Table 11 presents precisely which parameters were modified and what values were used in the Standard Design and Proposed Design.

Table 29: Modifications Made to Standard Design in Each Prototype to Simulate Proposed Code Change

Prototype ID	Climate Zone	Objects Modified	Parameter Name	Standard Design Parameter Value	Proposed Design Parameter Value
Laboratory	12	HVAC	HeatExchanger: AirToAir	No Heat Recovery	Air to Air Sensible heat recovery. 0.55 at 100% flow' 0.65 at 75%flow

CBECC calculates whole-building energy consumption for every hour of the year measured in kilowatt-hours per year (kWh/yr) and therms per year (therms/yr). It then applies the 2025 LSC hourly factors to calculate Lifecycle Energy Use in kilo British thermal units per year (kBtu/yr), source energy factors to calculate source energy use in kilo British thermal units per year (kBtu/yr), and hourly GHG emissions factors to calculate annual GHG emissions (metric tons of carbon dioxide emissions equivalent). CBECC also generates LSC savings values measured in 2026 present value dollars (2026 PV\$) and nominal dollars. CBECC also calculates annual peak electricity demand measured in kilowatts (kW).

The energy impacts of the proposed code change do vary by climate zone. The Statewide CASE Team simulated the energy impacts in Climate Zones 2, 3, 7, and 12 and applied the climate-zone specific LSC hourly factors when calculating energy and energy cost impacts. The Statewide CASE Team will expand the analysis to cover all 16 climate zones for the final report.

Per-unit energy impacts for nonresidential buildings are presented in savings per square foot. Annual energy, GHG, and peak demand impacts for each prototype building were translated into impacts per square foot by dividing by the floor area of the prototype building. This step allows for an easier comparison of savings across different building types and enables a calculation of statewide savings using the construction forecast that is published in terms of floor area by building type.

3.3.1.3 Statewide Energy Savings Methodology

The per-unit energy impacts were extrapolated to statewide impacts using the statewide construction forecasts that the CEC provided. The statewide construction forecasts estimate new construction/additions that would occur in 2026, the first year that the 2025 Title 24, Part 6 requirements are in effect (California Energy Commission 2022). They also estimate the amount of total existing building stock in 2026, which the Statewide CASE Team used to approximate savings from building alterations. The construction forecast provides construction (new construction/additions and existing building stock) by building type and climate zone. Appendix A presents additional information about the methodology and assumptions used to calculate statewide energy impacts.

3.3.2 Per-Unit Energy Impacts Results

Energy savings and peak demand reductions per unit are presented in Table 30. The presented savings for new construction. The per-unit energy savings figures do not account for naturally occurring market adoption or compliance rates.

Table 30: First-Year Energy Impacts Per Square Foot – Heat Recovery

Climate Zone	2	3	7	12
First-Year Electricity Savings (kWh)	0.08	0.01	0.03	0.19
First-Year Peak Demand Reduction (kW)	-0.4	0.0	0.0	0.04
First-Year Natural Gas Savings (kBtu)	30.16	9.89	0.57	24.63
First-Year Source Energy Savings (kBtu)	27.30	8.94	0.54	22.39
LSC Savings	18.53	6.12	0.60	16.09

3.4 Cost and Cost Effectiveness

3.4.1 Energy Cost Savings Methodology

Energy cost savings were calculated by applying the LSC hourly factors to the energy savings estimates that were derived using the methodology described in Section 3.3.1. LSC hourly factors are a normalized metric to calculate energy cost savings that accounts for the variable cost of electricity and natural gas for each hour of the year, along with how costs are expected to change over the period of analysis. In this case, the period of analysis used is 30 years.

The CEC requested energy cost savings over the 30-year period of analysis in both 2026 present value dollars (2026 PV\$) and nominal dollars. The cost-effectiveness analysis uses energy cost values in 2026 PV\$. Costs and cost effectiveness using and 2026 PV\$ are presented in Section 3.4 of this report. CEC uses results in nominal dollars to complete the Economic and Fiscal Impacts Statement (From 399) for the entire package of proposed change to Title 24, Part 6. Appendix G presents energy cost savings results in nominal dollars.

3.4.2 Energy Cost Savings Results

Per-unit energy cost savings for newly constructed buildings that are realized over the 30-year period of analysis are presented 2026 present value dollars (2026 PV\$) in Table 31 for new construction / additions and alterations, respectively. The LSC hourly factors methodology allows peak electricity savings to be valued more than electricity savings during non-peak periods.

Table 31: 2026 PV LSC Savings Over 30-Year Period of Analysis – Per Square Foot – New Construction, Additions, and Alterations – Laboratory

Climate Zone	30-Year LSC Electricity Savings (2026 PV\$)	30-Year LSC Natural Gas Savings (2026 PV\$)	30-Year Total LSC Savings (2026 PV\$)
2	0.27	18.25	18.53
3	0.04	6.08	6.12
7	0.24	0.36	0.60

12	0.94	15.15	16.09
----	------	-------	-------

3.4.3 Incremental First Cost

A real lab project was used to estimate the total incremental cost. Statewide CASE Team member, Taylor Engineers, recently designed a lab building in Pleasanton, California with heat recovery. Features of the project include:

- 20,000 ft² of lab spaces
- Gas boilers
- Air-cooled chillers
- 46 percent sensible heat recovery effectiveness as design cooling conditions
- 50 percent sensible heat recovery effectiveness as design heating conditions

This real project effectively serves as the “proposed” case with heat recovery. To develop the base case without heat recovery and determine the incremental cost of heat recovery, Taylor Engineers redesigned the job without heat recovery. This included:

- Changes that make the base case more expensive:
 - Increasing the capacity of the chillers by approximately 23 percent
 - Increasing the capacity of the cooling coils
 - Increasing the capacity of the chilled water pumps
 - Increasing the capacity of the boilers by approximately 38 percent
 - Increasing the capacity of the hot water pumps
 - Increasing the capacity of the VAV box reheat coils
- Changes that make the base case less expensive:
 - Removing the exhaust air heat recovery coil
 - Removing the heat recovery coil bypass damper
 - Reducing the total pressure drop of the exhaust fans
 - Eliminating the heat recovery pumps and associated piping
 - Eliminating the heat recovery coil from the air handler
 - Reducing the total pressure drop of the supply fans (removing the heat recovery coil reduces pressure more than the deeper VAV box reheat coils add)

One of the mechanical contractors who provided cost estimates for proposed case re-estimated the base case without heat recovery.

Taylor Engineers also redesigned the job with air-to-water heat pumps (with and without heat recovery), rather than with gas boilers. The mechanical contractor then estimated the project with heat pumps with and without heat recovery. These incremental costs include full installed costs, including labor and materials.

The total incremental cost of heat recovery for the project with air-to-water heat pumps was negative. That is, heat recovery reduced the total cost. The main reason for this discrepancy between boilers and heat pumps is because the installed cost of heat pumps is about six times the cost of boilers. Reducing the size of the heat pumps more than pays for the heat recovery system but reducing the size of the boilers does not save enough to cover the cost of the heat recovery system.

Table 32: Incremental Cost Data for Heat Recovery

Incremental Cost in \$ per ft ²	Versus Natural Gas Baseline	Versus Heat Pump Baseline
Chillers	(\$ 1.38)	(\$ 1.38)
Heat Recovery Coil	\$ 1.68	\$ 1.68
Heat Recovery Piping	\$ 1.68	\$ 1.68
Heat Recovery Pumps/VFDs	\$ 0.14	\$ 0.14
CHW Pumps/VFDs	(\$ 0.55)	(\$ 0.55)
HW Pumps/VFDs	(\$ 0.15)	(\$ 0.15)
Exhaust Fans/VFDs	\$ 0.28	\$ 0.28
Terminal Units	(\$ 0.30)	(\$ 0.30)
HW Piping	(\$ 0.13)	(\$ 0.13)
CHW Piping	\$ 0.00	\$ 0.00
Controls	\$ 0.20	\$ 0.20
Boilers	(\$ 0.99)	\$ 0.00
ASHPs	\$ 0.00	(\$ 9.28)
NPV of Annual Maintenance	\$ 0.19	\$ 0.19
Total (\$/ft²)	(\$ 0.67)	(\$ 7.62)

3.4.4 Incremental Maintenance and Replacement Costs

A Bay Area HVAC service contractor estimated the annual maintenance of the heat recovery system: "Maintenance might be a couple hundred dollars." In the incremental cost above, the Statewide CASE Team included \$500/year or about \$10,000 over the life of the system.

There is an incremental replacement cost of the ASHPs because they have less than a 30-year life. The capacities of the ASHPs are higher in the baseline than in the proposed so the incremental replacement cost is negative. This cost was not included in the analysis because the total incremental cost for the heat pump baseline is already negative, which indicates the payback is immediate.

3.4.5 Cost Effectiveness

This measure proposes a primary prescriptive requirement. As such, a cost analysis is required to demonstrate that the measure is cost effective over the 30-year period of analysis.

The CEC establishes the procedures for calculating cost effectiveness. The Statewide CASE Team collaborated with CEC staff to confirm that the methodology in this report is consistent with their guidelines, including which costs were included in the analysis. The incremental first cost and incremental maintenance costs over the 30-year period of analysis were included. The LSC savings from electricity and natural gas savings were also included in the evaluation. Design costs were not included nor were the incremental costs of code compliance verification.

According to the CEC’s definitions, a measure is cost effective if the benefit-to-cost (B/C) ratio is greater than 1.0. The B/C ratio is calculated by dividing the cost benefits realized over 30 years by the total incremental costs, which includes maintenance costs for 30 years. The B/C ratio was calculated using 2026 PV costs and cost savings.

Results of the per-unit cost-effectiveness analyses are presented in Table 33.

The proposed measure saves money over the 30-year period of analysis relative to the existing conditions. The Statewide CASE Team simulated the analysis in three climate zones 2, 7, and 12. The proposed code change is cost effective in Climate Zones 2 and 12. In the final draft, the analysis will be expanded to include all California 16 climate zones in the final draft.

Table 33: 30-Year Cost-Effectiveness Summary Per Square Foot – New Construction, Additions, and Alterations

Climate Zone	Benefits LSC Savings + Other PV Savings ^a (2026 PV\$)	Costs Total Incremental PV Costs ^b (2026 PV\$)	Benefit-to-Cost Ratio
2	18.53	0.67	27.65
3	6.12	0.67	9.14
7	0.60	0.67	0.89
12	16.09	0.67	24.01

- a. **Benefits: LSC Savings + Other PV Savings:** Benefits include LSC Savings over the period of analysis (California Energy Commission 2022). Other savings are discounted at a real (nominal – inflation) three percent rate. Other PV savings include incremental first-cost savings if proposed first cost is less than current first cost, incremental PV maintenance cost savings if PV of proposed maintenance costs is less than PV of current maintenance costs, and incremental residual value if proposed residual value is greater than current residual value at end of CASE analysis period.

- b. **Costs: Total Incremental Present Valued Costs:** Costs include incremental equipment, replacement, and maintenance costs over the period of analysis. Costs are discounted at a real (inflation-adjusted) three percent rate and if PV of proposed maintenance costs is greater than PV of current maintenance costs. If incremental maintenance cost is negative, it is treated as a positive benefit. If there are no total incremental PV costs, the B/C ratio is infinite.

3.5 First-Year Statewide Impacts

3.5.1 Statewide Energy and Energy Cost Savings

The Statewide CASE Team calculated the first-year statewide savings for new construction and additions by multiplying the per-unit savings, which are presented in Section 3.3.2, by assumptions about the percentage of newly constructed buildings that would be impacted by the proposed code. The statewide new construction forecast for 2026 is presented in Appendix A, as are the Statewide CASE Team's assumptions about the percentage of new construction that would be impacted by the proposal (by climate zone and building type).

The Statewide CASE Team calculated the statewide impacts by multiplying the per-unit energy savings by the 2026 new construction forecast for labs. The first-year energy impacts represent the first-year annual savings from all buildings that were completed in 2026. The 30-year energy cost savings represent the energy cost savings over the entire 30-year analysis period. The statewide savings estimates do not take naturally occurring market adoption or compliance rates into account.

The tables below presents the first-year statewide energy and energy cost savings from newly constructed buildings (Table 34) and alterations (Table 35). This draft report presents results for Climate Zones 2, 3, 7, and 12. The proposal will apply to all climate zones, and results for the remaining climate zones will be presented in the final CASE Report. The statewide savings estimates are underestimated for the draft report because savings from the remaining climate zones are not accounted for yet.

Table 34: Statewide Energy and Energy Cost Impacts – New Construction and Additions

Climate Zone	Statewide New Construction and Additions Impacted by Proposed Change in 2026 (Million Square Feet)	First-Year ^a Electricity Savings (GWh)	First-Year Peak Electrical Demand Reduction (MW)	First-Year Natural Gas Savings (Million Therms)	First-Year Source Energy Savings (Million kBtu)	30-Year Present Valued Energy Cost Savings (Million 2026 PV\$)
2	139,677	0.01	(0.00)	0.04	3.81	\$2.59
3	940,564	0.01	(0.00)	0.09	8.41	\$5.76
7	195,234	0.01	0.00	0.00	0.11	\$0.12
12	315,980	0.06	(0.00)	0.08	7.07	\$5.08

Table 35: Statewide Energy and Energy Cost Impacts – Alterations

Climate Zone	Statewide New Construction and Additions Impacted by Proposed Change in 2026 (Million Square Feet)	First-Year ^a Electricity Savings (GWh)	First-Year Peak Electrical Demand Reduction (MW)	First-Year Natural Gas Savings (Million Therms)	First-Year Source Energy Savings (Million kBtu)	30-Year Present Valued Energy Cost Savings (Million 2026 PV\$)
2	145,964	0.01	(0.00)	0.04	3.99	\$2.70
3	1,344,252	0.02	(0.00)	0.13	12.02	\$8.23
7	625,716	0.02	0.00	0.00	0.34	\$0.37
12	441,896	0.09	(0.00)	0.11	9.89	\$7.11

a. First-year savings from all buildings completed statewide in 2026.

3.5.2 Statewide Greenhouse Gas (GHG) Emissions Reductions

The Statewide CASE Team calculated avoided GHG emissions associated with energy consumption using the hourly GHG emissions factors that CEC developed along with the 2025 LSC hourly factors and an assumed cost of \$123.15 per metric tons of carbon dioxide equivalent emissions (metric tons CO₂e).

The 2025 LSC hourly factors used in the lifecycle cost-effectiveness analysis include the monetary value of avoided GHG emissions based on a proxy for permit costs (not social costs).²¹ The cost-effectiveness analysis presented in Section 3.4 of this report does not include the cost savings from avoided GHG emissions. To demonstrate the cost savings of avoided GHG emissions, the Statewide CASE Team disaggregated the

²¹ The permit cost of carbon is equivalent to the market value of a unit of GHG emissions in the California Cap-and-Trade program, while social cost of carbon is an estimate of the total economic value of damage done per unit of GHG emissions. Social costs tend to be greater than permit costs. See more on the Cap-and-Trade Program on the California Air Resources Board website: <https://ww2.arb.ca.gov/our-work/programs/cap-and-trade-program>.

value of avoided GHG emissions from the other economic impacts. The authors used the same monetary values that are used in the LSC hourly factors.

Table 36 presents the estimated first-year avoided GHG emissions of the proposed code change. During the first year, GHG emissions of 30 (metric tons CO₂e) would be avoided.

Again, this draft report presents results for Climate Zones 2, 3, 7, and 12. The proposal will apply to all climate zones, and results for the remaining climate zones will be presented in the final CASE Report. The statewide savings estimates are underestimated for the draft report because savings from the remaining climate zones are not accounted for yet.

Table 36: First-Year Statewide GHG Emissions Impacts

Measure	Electricity Savings ^a (GWh/yr)	Reduced GHG Emissions from Electricity Savings ^a (Metric Tons CO ₂ e)	Natural Gas Savings ^a (Million Therms/yr)	Reduced GHG Emissions from Natural Gas Savings ^a (Metric Tons CO ₂ e)	Total Reduced GHG Emissions ^a (Metric Ton CO ₂ e)	Total Monetary Value of Reduced GHG Emissions ^b (\$)
Heat Recovery	0.225	4	0.5033	2,750	2,754	339,125

a. First-year savings from all buildings completed statewide in 2026.

b. GHG emissions factors are included in the LSC hourly factors published by CEC here

3.5.3 Statewide Water Use Impacts

The proposed code change would not result in water savings.

3.5.4 Statewide Material Impacts

The proposed code change would not result in material impacts.

4. Exhaust Fan Control

4.1 Measure Description

4.1.1 Proposed Code Change

This proposed change would add an additional design fan power and control combination to the prescriptive requirements in Section 140.9(c) for laboratory exhaust fan system power consumption. These requirements would apply to all laboratory fan exhaust systems with a design flow rate greater than 10,000 cubic feet per minute (cfm). The laboratory occupancies covered are occupancy classes B (business), L (laboratory) and H (high-hazard). This requirement would also apply to replaced laboratory ventilation systems.

The Statewide CASE Team recommends that the compliance software explicitly model staging of exhaust fans and use of an outside air by-pass damper to maintain required minimum stack velocities without extracting excess conditioned air from the laboratory space. This model adjusts exhaust fan power without changing ventilation loads of the space. This model would more accurately model not just the new simple turndown control system but also the existing wind responsive and the monitored contaminant control systems.

4.1.2 Justification and Background Information

4.1.2.1 Justification

This proposal provides added design flexibility for laboratory exhaust systems by adding an alternate pathway for complying with the fan system power consumption requirements. This pathway places a 1.3 W/cfm fan motor electrical power limit at design conditions but also requires that the fan system is capable of varying the speed of the fans and reduce airflow through the system by at least 40 percent. To show that the system can reduce airflow by at least 40 percent without exposing people to unacceptable odor or contaminate concentrations, the proposed design must be modelled at the ASHRAE one percent design wind speed (99 percent of the time the wind speed is lower) at the minimum system air flow rate. The location and the height of the exhaust stacks are designed so that at the ASHRAE one percent wind speed the design contaminant concentrations downwind would be below health and odor limits, as defined by the 2018 American Conference of Governmental Industrial Hygienists Threshold Limit Values and Biological Exposure Indices.

This proposed simple control requires airflow modelling of the exhaust and air intake design in the context of its surroundings. However, the two other more complex controls approach that are already in the code also require airflow modelling to develop the

correct mapping between minimum stack velocity versus windspeed or stack contaminant level.

4.1.2.2 Background Information

The current fan system power consumption requirements in Section 140.9(c) provide three combinations of laboratory exhaust fan power and control options. The first option is a system with high system design fan efficacy (0.65 W/cfm) with a constant exhaust stack flow rate and two options with lower design fan efficacy (1.30 W/cfm at design conditions) but with controls that reduce stack flow rate in response to ambient wind velocity or in response to the measured contaminant concentrations in the exhaust system plenum. This proposal would add a fourth fan power and control option that allows design fan power similar to the other controls that modulate stack flow rates but with a less complex fan speed control.

The system would be designed with variable speed control and with the capability of safely decreasing stack flow to no greater than 60 percent of design flow rate in response to space VAV zone controls during normal operation. The system would be designed so that at minimum airflow and under ASHRAE, one percent design windspeed conditions (exceeded only 86 hours per year), the discharge would maintain downwind concentrations below health and odor limits. This type of control does not rely on the maintained accuracy of measured windspeed or contaminant sensors but rather the inherent modelled design of stack height, minimum velocity of exhaust flow and the dispersion characteristics of the site. Given that fan power would be reduced to 40 percent at 60 percent of stack flow and that the system would likely be running at its reduced speed for most hours, this control has been found to use less energy on an annual basis than the constant stack flow rate control with the lowest design fan wattage but without requirements for modulating stack flow rates.

This proposed change would more clearly differentiate the exhaust airflow from lab spaces from the exhaust fan system airflow rate. The lab exhaust airflow is all the airflows out of the lab that are required to maintain the safety of the occupants inside of the building including the airflow required to maintain the appropriate air changes in the space, the appropriate face velocities of fume hoods, and air required for other exhaust streams such as chemical storage cabinets, chemical storage cabinets etc. The exhaust fan system flowrate is the airflow that enters the fans and also includes by-pass air. By-pass air is typically outdoor air introduced in the exhaust fan plenum via a damper and is used to maintain sufficient stack air flow rate so that the velocity of the stack gases has enough momentum to sufficiently overcome the effect of winds that blow the contaminated airstream back towards the ground towards people and building ventilation inlets. Some laboratory exhaust systems make use of induction fans which have openings downstream of the fan to induce or entrain air which also adds to the volume and velocity of the airstream leaving the stack. This induced or entrained air is

not included in the exhaust fan system airflow. See Figure 6 for an illustration of the different components of fan system airflow (lab exhaust air and bypass air) and entrained air that is not part of exhaust fan system airflow.

The definitions above result in more clarity of what systems are covered and what is the fan efficacy metric to be used.

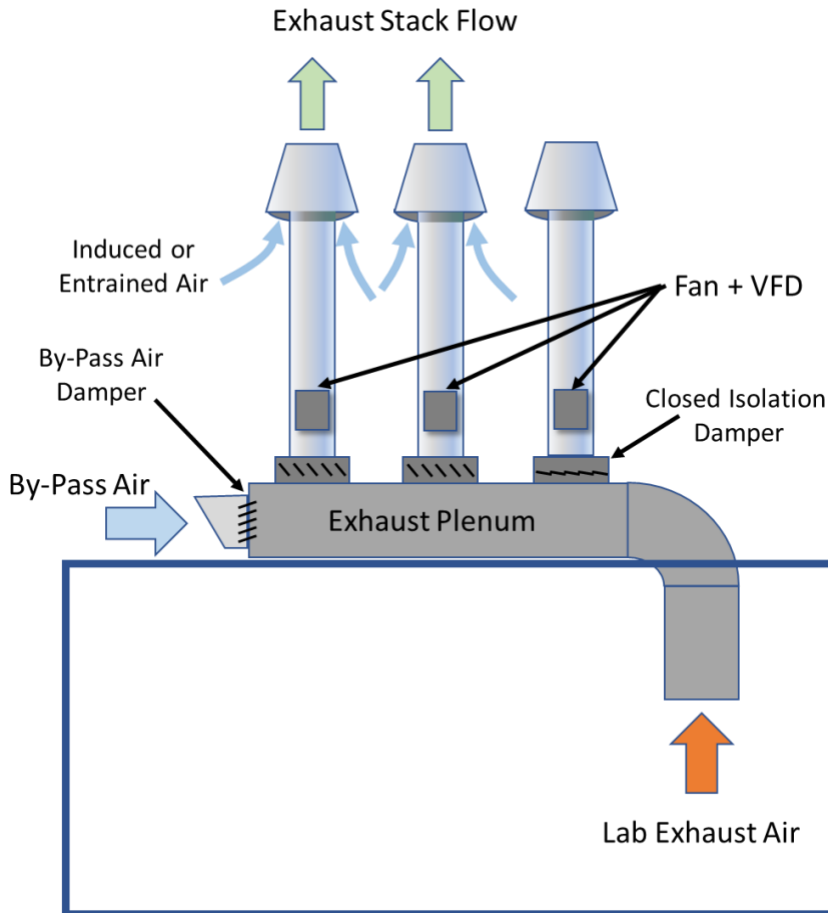

Figure 6: Components of lab exhaust flows.

In designing exhaust systems the metric of interest is the stack velocity which is a function of the stack flowrate. For exhaust systems that do not have entrained air the stack flow rate is the same as the airflow rate entering the fan. For induction fans, the stack flow rate is the fan entering flowrate plus the bypass flow rate, thus the fan flow rate is the stack flow rate minus the induced airflow. Induction fans typically have both the inlet flowrate as well as the total flowrate.

The use of air system airflow for the basis of the W/cfm metric results in a compliance path that can more easily be derived from the exhaust fan curves and does not result in a side calculation of subtracting off bypass flow when bypass is used in the design configuration or during minimum flow.

In its simplest format a variable volume (VAV) laboratory exhaust system is designed to maintain a relatively constant pressure in the exhaust plenum and as exhaust loads decrease in the laboratory due to closing of fume hood sashes and closing off snorkels and other devices, the negative static pressure in the exhaust plenum will become even more negative. If the exhaust fan is constant speed, the negative pressure in the duct is stabilized by opening an outdoor air bypass damper. Opening the by-pass damper does two things: 1) it reduces the negative pressure in the exhaust system plenum and 2) it maintains the exhaust stack flow rate. Thus variable volume exhaust of the lab can be achieved without varying the speed of the fan and maintains a constant negative pressure in the exhaust plenum so stable control is achieved. This type of control saves energy as reduced amounts of conditioned air are exhausted as compared to a constant volume system. This type of control does not save exhaust fan energy as the reduced exhaust airflow from the lab spaces is made up with bypass air and thus the exhaust fan system is operating at full load all the time the lab is operating. This control is allowed if the design fan wattage is 0.65 watts per cfm of fan system airflow without air filtration and 0.85 W/cfm with exhaust air filtration.

The current energy code allows higher design fan wattage if the flow rate out of the exhaust stack is modulated in response to measured contaminant concentrations in the exhaust plenum or in response to windspeed. These controls require a variable speed drive (VSD) to control the fan in addition to contaminant sensors or anemometers. Additionally, to safely reduce exhaust stack gas velocities, these systems require a contaminant dispersion model to map either plenum contaminant concentration to outdoor contaminant concentrations under high (ASHRAE one percent) wind speeds or map wind speed and direction to outdoor contaminant concentrations to estimated worst case contaminant concentration in the exhaust plenum.

This proposal recommends adding what ANSI/ASSP Z9.5-2022 calls “*Simple turndown systems.*” The simple turndown system reduces the amount of air exiting from the exhaust stack based on the amount of air exhausted by the lab exhaust system down to a pre-calculated minimum stack exhaust flow rate. A dispersion model is used to calculate this minimum exhaust flow rate based on estimated worst case contaminant concentration in the exhaust airstream and environmental conditions up to the one percent ASHRAE wind speed. As laboratory exhaust air drops, the exhaust air without bypass air exits out of the exhaust stack – to maintain the desired negative pressure in the exhaust system plenum the fan speed drops, and lab exhaust amounts drops. This saves fan energy as compared to the base case control allowed for the low design wattage system which maintains constant fan speed and constant exhaust stack flow. When the lab exhaust air flow rates drop below the precalculated minimum allowable stack flow rate, the fan speed drops no further and starts modulating the by-pass air damper open enough to maintain the minimum stack flow rate.

This proposal requires that the minimum acceptable circulation rate of laboratory spaces be no greater than 60 percent of the design fan system airflow rate, the minimum acceptable stack flow rate be no greater than the design stack flow rate and at this flow rate consume no more than 40 percent of design fan power. The turndown to 60 percent of design flow was recommended by stakeholders as being achievable in many instances and the 40 percent of design fan power uses the conservative square of the flowrate rate to estimate fan power instead of the fan affinity law cube of the flowrate. This accounts for a portion of the exhaust system being at constant pressure while the pressure drop in the remaining portion of the duct system being roughly proportional to the square of the flowrate through the ducts.



Insufficient Plume Rise
High Levels of Re-entrainment
Potentially Unsafe



Excessive Plume Rise
Low Levels of Re-entrainment
Energy Intensive



Optimized Plume Rise
Low Levels of Re-entrainment
Reduced Energy Consumption

Figure 7: Dispersion modelling examples.

Source: (International Institute for Sustainable Laboratories (I2SL) 2021).

Additionally, this proposal places similar efficiency requirements on the contaminant monitoring and windspeed responsive controls as for the simple turn down controls. All

three controls options must have a design exhaust system wattage no greater than 1.3 W/cfm, minimum lab exhaust flow rate be no greater than 60 percent of the design flow rate and these systems consume no more than 40 percent of design fan power at 60 percent of the stack flow rate. This minimum lab exhaust flow is also called the circulation rate because this is typically the minimum ACH of the space when fume hoods and other devices are at their minimum flow rate.

All of these options are an optional prescriptive compliance path as compared to the base compliance path of no fan speed control with a 0.65 W/cfm design wattage. To assure these systems use less energy:

- The simple turndown control must not require more than 60 percent of the design stack flow rate during normal operation.
- The wind responsive system shall have a stack flow rated no greater than 60 percent of the design flow rate, 70 percent of the hours during a Typical Meteorological Year (TMY) for the site.
- The contaminant monitoring system stack flow rates are below 60 percent of the design flow rate whenever the contaminant levels in the exhaust plenum are less than the threshold contaminant levels.

The 2022 updates to ANSI/ASSP Z9.5 Laboratory Ventilation, has included Appendix 3, “Design Procedures” which discusses among other things how to reduce energy consumption using one of three control strategies:

- Simple turndown systems
- Wind responsive systems
- Monitored systems

The wind responsive systems controls description closely matches the current requirements in 2022 Title 24 Part 6 Section 140.9(c)3C and the monitored systems control description closely matches the current requirements in Section 140.9(c)3D. However California’s current energy code does not have a comparable prescriptive laboratory exhaust control to the ANSI/ASSP Z9.5 simple turndown control.

This proposal would simplify the laboratory exhaust system’s control requirements and add more flexibility by adding simple turndown control. Given that ANSI/ASSP Z9.5 Appendix 3 provides a description of the safety requirements for the wind responsive and monitored system controls, these can be removed from Title 24, part 6 and focus on the energy savings aspects of these controls without details for fault detection and diagnostics.

4.1.3 Summary of Proposed Changes to Code Documents

The sections below summarize how the standards, Reference Appendices, Alternative Calculation Method (ACM) Reference Manuals, and compliance documents would be modified by the proposed change.²² See Section 6 of this report for detailed proposed revisions to code language.

4.1.3.1 Specific Purpose and Necessity of Proposed Code Changes

Each proposed change to language in Title 24, Part 1 and Part 6 as well as the reference appendices to Part 6 are described below. See Section 7.2 of this report for marked-up code language.

Section: Section 140.9(c)3

Specific Purpose: This section has been simplified for improved clarity and has added the simple turndown control system for controlling exhaust fans.

Necessity: Updates to the 2022 version of ANSI Z9.5 Laboratory Ventilation, include in Appendix 3 descriptions of: simple turndown systems, wind responsive systems, and monitored systems. Wind responsive systems and monitored systems were previously described in 140.9(c)3C and D, respectively. The changes proposed here would add the simple turndown system to the list of compliant systems and because the wind responsive systems and monitored systems are now described in ANSI Z9.5, and they no longer need to have the detailed description in Title 24, Part 6. The energy criteria for the controls (no greater than 1.3 W/cfm at design conditions and no greater than 40 percent of design fan power at 60 percent of stack design flow rate) result in fan energy savings as compared to the base design of 100 percent design flow rate at 0.65 W/cfm. The added control option increases flexibility and creates the opportunity for additional savings as directed by the California Public Resources Code Section 25213 and 25402.

4.1.3.2 Specific Purpose and Necessity of Changes to the Nonresidential ACM Reference Manual

The purpose and necessity of proposed changes to the Nonresidential ACM Reference Manual are described below. See Section 7.4 of this report for the detailed proposed revisions to the text of the ACM Reference Manual.

Section: 5.6.7 Zone Exhaust, EXHAUST FAN SCHEDULE

Specific Purpose: This change clarifies that all labs where the design exhaust rate is above the minimum ventilation rate are variable volume. That is, exceptions for constant

²² Visit EnergyCodeAce.com for trainings, tools and resources to help people understand existing code requirements.

volume are removed. The exhaust rate varies based on the load, the fume hood schedule and the minimum ventilation rate.

Section: 5.7.3 Fan and Duct Systems

Specific Purpose: Fan power control should be updated to model a bypass damper that adds additional air flow rate at ambient conditions to the exhaust airstream and thus increase fan energy. Controls should be capable of modelling:

- Standard Design – constant fan system airflow while lab exhaust airflow is modulating. When the total lab exhaust airflow is less than the design fan system airflow, by-pass outside air is added so fan system airflow is constant.
- Simple turndown control – total stack airflow is modulating according to calculated lab exhaust flow schedule with added by-pass outside air only added to fan system airflow when lab exhaust airflow drops below the defined minimum fan system airflow.
- Wind responsive control – total stack airflow is simulated according to the mapping of wind speed and direction to total stack airflow. The difference between the lab exhaust airflow and the stack airflow is by-pass airflow that is at ambient conditions.

Necessity: These changes are necessary to simulate alternative exhaust fan controls and provide credit within they result in source energy reductions as compared to the system default of low fan power but no variable fan speed control. This provides the capability to eventually require low fan power and at least simple turndown control as the future base case.

The exhaust fan control requirements are prescriptive options to the primary requirement of fan power not exceeding 0.65 W/cfm without added filtration and 0.85 W/cfm with added filtration but with no fan speed control requirements. The low design wattage with no controls is a reasonable standard design conditions and is listed in the *Exhaust Fan Power Index* subsection of Section 5.7.3 Fan and Duct Systems. Currently the ACM ruleset adequately models the thermal impacts of laboratory ventilation and exhaust air, however fan energy is not correctly captured.

The exhaust fan system simulation is not capturing the energy to move bypass air. The original two fan control options (wind speed sensing and contaminant sensing controls) and the proposed simple turndown fan control option reduce by-pass air to save fan energy. To model the benefit of these controls one would have to model the fan energy impact of bypass air in the primary baseline case without the fan control and model this fan energy impact of the various fan control options. Accurately modelling exhaust fan energy is needed to provide these additional exhaust fan control options in the performance approach. Having these control options developed in CBECC results in

this compliance option being modelled correctly rather than having to result to ad hoc spreadsheets or various work arounds in CBECC being used.

Section: 5.7.3 Fan and Duct Systems, EXHAUST FAN CONTROL METHOD

Specific Purpose: This change removes the exception to VAV for labs greater than 10 ACH.

Necessity: This change is necessary to align the simulation assumptions with the new code requirements.

4.1.3.3 Summary of Changes to the Nonresidential Compliance Manual

Section 10.7 of the Nonresidential Compliance Manual would need to be revised. As it relates to the changes proposed for the exhaust system prescriptive controls options that are described in Section 10.7.3.4 Exhaust Fan System Power Consumption. This section would need to be rewritten. After describing the no-control option with lower design fan power, this section would start with the criteria for using the various fan controls:

- a. Design fan power no greater than 1.3 W/cfm of exhaust air. The exhaust air volume for this calculation does not include bypass air.
- b. Minimum exhaust air flow rate is no greater than 60 percent of the design exhaust air flow rate. This description would discuss comparison of the minimum exhaust flow rate – typically at night when the air changes per hour is setback and most of the fume hoods close to their minimum. This would also include the design airflow rate which likely includes some diversity of fume hood operation but also worst-case generation of fumes and atmospheric conditions which include high wind speeds (typically up to the one percent wind speed).
- c. System has a VFD control of fans and exhaust system fan power at 60 percent of design stack flow rate no greater than 40 percent of system power at design flow rate.
- d. Stack airflow rate controlled to be no greater than the greater of the lab exhaust flow rate and the minimum acceptable stack flow rate. The primary physical outcome of this requirement is that the bypass damper is closed until the lab flow rate drops below the minimum acceptable stack flow rate.

After describing the criteria this section of the compliance manual would describe how minimum stack flow rate is calculated at a given point in time as part of the control algorithm and would reference the ANSI Z9.5-2022 as the basis of these control algorithms:

- a. Simple turndown control system. Minimum stack exhaust flow rate is precalculated based on worst case contaminant concentration in exhaust gases and windspeed up to the ASHRAE one percent wind speed.

- b. Wind responsive control system. The minimum allowable stack flow rate is determined from measured wind speed by anemometers located at site. Relationship of wind speed and wind direction mapped to the minimum allowable stack flow rate based on detailed model of the configuration of exhaust stack relative to the geometry of the site, relative probabilities of wind speed and direction from typical meteorological year (TMY) data. This control is prescriptively allowed if the allowable minimum stack flow rate is less than 60 percent of the design stack flow rate for at least 70 percent of the hours during a TMY.
- c. Contaminant monitoring system. The minimum allowable stack flow rate determined from measured contaminant concentrations in the exhaust plenum. The minimum stack flow rate is based on worst case wind direction and high wind speeds up to the one percent ASHRAE windspeed. The system must be able to reduce the stack flow rate to 60 percent or less than the design stack flow rate when the measured contaminant in the exhaust plenum is low i.e. below the threshold contaminant concentration. This requires a discussion of how well the sensor is detecting a contaminant concentration that is a proxy for the most toxic material in the exhaust airstream.

4.1.3.4 Summary of Changes to Compliance Documents

The proposed code change would modify the compliance documents listed below. Examples of the revised documents are presented in Section 7.5. In general, compliance is simplified as this section has been modified to focus only on the energy performance of the different control strategies with an expectation that by reference to ANSI Z9.5. The pre-existing level of scrutiny that is afforded to laboratory fume systems, that duplication of safety requirements is not needed in the energy code.

- NRCC-PRC (process) compliance form. Add Simple turndown controls to pull-down menu for “Airflow Reduction Compliance Method:” Include design flow rate and minimum allowed stack flow rate. Add a calculation line so that if minimum stack flow rate is not 60 percent or less, the form would note that none of the control alternatives would be allowed in lieu of the fan power limitation (0.65 W/cfm with no filtration and 0.85 W/cfm with filtration). Similarly requires data entry for the design fan power and the fan power at the minimum allowable flow rate. Add a calculation line and if the fan power at the minimum flow rate is greater than 40 percent the form would note that none of the control alternatives would be allowed in lieu of the fan power limitation.
- 2022 NRCA-PRC-14-F and Installer and Inspector Quick reference. Update form to exercise the simple turn down controls system – open all fume hoods on the system and make note of fan speed and by-pass damper position. Close fume hoods and other devices and see if exhaust fan first slows down and make note

of minimum fan speed before by-pass damper starts opening. Make sure with reduced space airflow that by-pass damper is modulated correctly so that fan speed does not rise as exhaust flow from space drops.

4.1.4 Regulatory Context

4.1.4.1 Determination of Inconsistency or Incompatibility with Existing State Laws and Regulations

Section 140.9(c)3 in Title 24, Part 6 includes prescriptive requirements for laboratory exhaust. Three alternative prescriptive requirements are available: (1) a fan power limitation, (2) use of wind-responsive control, or (3) use of contaminant sensing control. This proposal would add a fourth prescriptive alternative that allows for laboratory exhaust designs that may not be able to comply under the existing options but may potentially offer lower energy performance by avoiding the need for bypass air.

Regardless of energy efficiency strategies, laboratory exhaust stacks must be designed to comply with safety requirements:

- Cal/OSHA Title 8 Section 5154.1(e)(4) safety requirements, with one of the following methods: (1) chemical treatment, (2) dilution prior to discharge, (3) locked access), or (4) discharges 7 ft or higher above the roof (Cal/OSHA 2021).
- Compliance with discharge requirements in ANSI Z9.5-2012 is required by Title 24, Part 6 Section 140.9(c)3. Section 5.4.6 of Z9.5-2012 requires laboratory exhaust discharges to be located 10 ft or greater above adjacent roof lines and air intakes, and discharge velocities greater than 3000 fpm, unless designs demonstrate that dilution criteria are met (ANSI/ASSP 2012).

4.1.4.2 Duplication or Conflicts with Federal Laws and Regulations

There are no relevant federal laws or regulations.

4.1.4.3 Difference From Existing Model Codes and Industry Standards

This proposal is developed from the description of the *simple turndown systems* control strategy in the Energy Efficient Design and Operation subsection to Appendix 3: Design Procedures for Laboratory Exhaust Systems in ANSI/ASSP Z9.5-2022 “Laboratory Ventilation” developed by the American Society of Safety Professionals. This proposal more closely harmonizes with the Z9.5 standard by adding the referenced control strategy.

4.1.5 Compliance and Enforcement

When developing this proposal, the Statewide CASE Team considered methods to streamline the compliance and enforcement process and how negative impacts on market actors who are involved in the process could be mitigated or reduced. This section describes how to comply with the proposed code change. It also describes the

compliance verification process. Appendix E presents how the proposed changes could impact various market actors.

The compliance verification activities related to this measure that need to occur during each phase of the project are described below:

- **Design Phase:** The laboratory exhaust system mechanical designers would work with an airflow dispersion expert to identify the minimum acceptable flow rate under worst case conditions that would be allowable for the stack geometry in the context of the physical conditions of the surrounding built environment and historical weather files of wind speed and direction for the site. In some cases, the contaminant dispersion simulation model is validated with a scale model in a wind tunnel. This process is described in ANSI Z9.5-2022.
- **Permit Application Phase:** Typically, the mechanical engineering firm responsible for the design would also be filling out energy code compliance documentation for the exhaust system. They would be filling out the NRCC-PRC (process) compliance form, describing compliance with the maximum allowed fan power, what type of fan control is used, and whether or not fume hoods have automatic sash controls. This proposed measure would add “Simple turn down control” to the pull-down list of other controls currently allowed to claim a relaxation in fan power W/cfm limitation. The other controls currently on the pull-down list are: “Volume flow rate @ stack controlled by anemometer” or “Volume flow rate @ stack controlled by contaminant sensor.” This form also indicated that the acceptance test form NRCA-PRC-14-F Lab Exhaust Ventilation Systems must be filled out. Note that this is an acceptance test that does not require an ATT (acceptance test technician) but rather a field technician that is experienced in setting up laboratory exhaust controls. The permit application is reviewed by the plans examiner. However, a significant aspect of compliance relies on the expertise, integrity and liability exposure of the design professionals.
- **Construction Phase:** The mechanical contractor installs the duct work fans and exhaust stacks in accordance with the specification on the laboratory exhaust system plans. The mechanical contractor also fills out the NRCI-PRC-E process equipment installation certificate to indicate that their installation is to code as defined in the construction documents and compliance documents. This is an opportunity to identify changes in the as-built plans and show that these changes are still compliant with the intent of the compliance documentation. Typically, a specialized laboratory controls contractor would install the controls and commission the system. Part of the commissioning process is to run the system through the manufacturer recommended steps or a commissioning process developed by the design professional, then also conduct the code required

acceptance test and if needed adjusts until the system passes the acceptance tests.

- **Inspection Phase:** Building inspection is primarily looking for health and safety violations so the focus is on fire safety, penetrations through fire separations and the like. Unlike most other ductwork, laboratory exhaust system ductwork is not allowed to have fire dampers as the concern is that the exhaust system is able to exhaust toxic fumes during a fire. Because the systems are complex, much of enforcement is focused on making sure that the installed designs are in accordance with the building plans. The installation certificate provides the assurance that the fan energy in W/cfm is compliant. In terms of energy performance, the acceptance tests for exhaust system controls and fume hood controls provide much of the controls enforcement through a third party – the field technician.

4.2 Market Analysis

4.2.1 Current Market Structure

The Statewide CASE Team performed a market analysis with the goals of identifying current technology availability, current product availability, and market trends. It then considered how the proposed standard may impact the market in general as well as individual market actors. Information was gathered about the incremental cost of complying with the proposed measure. Estimates of market size and measure applicability were identified through research and outreach with stakeholders including utility program staff, CEC staff, and a wide range of industry actors. In addition to conducting personalized outreach, the Statewide CASE Team discussed the current market structure and potential market barriers during a public stakeholder meeting that the Statewide CASE Team held on January 31, 2023.

4.2.2 Technical Feasibility and Market Availability

Exhaust fan control allows for another pathway to compliance for fan power and control requirements by allowing for a reduced power fan system that is not reliant on a closed loop sensor for windspeed or contaminant sensors. This allows for a simpler design and implementation while allowing a turndown of airflow of 60 percent of the design flow rate, which in turn reduces energy consumption. This control strategy is one of three energy savings fan control strategies listed in the *Energy Efficient Design and Operation* subsection to Appendix 3 Design Procedures for Laboratory Exhaust Systems in ANSI/ASSP Z9.5-2022.

4.2.3 Market Impacts and Economic Assessments

4.2.3.1 Impact on Builders

Builders of residential and commercial structures are directly impacted by many of the measures proposed by the Statewide CASE Team for the 2025 code cycle. It is within the normal practices of these businesses to adjust their building practices to changes in building codes. When necessary, builders engage in continuing education and training to remain compliant with changes to design practices and building codes.

California’s construction industry comprises approximately 93,000 business establishments and 943,000 employees (see Table 2). For 2022, total estimated payroll will be about \$78 billion. Nearly 72,000 of these business establishments and 473,000 employees are engaged in the residential building sector, while another 17,600 establishments and 369,000 employees focus on the commercial sector. The remainder of establishments and employees work in industrial, utilities, infrastructure, and other heavy construction roles (the industrial sector).

Table 37: California Construction Industry, Establishments, Employment, and Payroll in 2022 (Estimated)

Building Type	Construction Sectors	Establishments	Employment	Annual Payroll (Billions \$)
Residential	All	71,889	472,974	31.2
Residential	Building Construction Contractors	27,948	130,580	9.8
Residential	Foundation, Structure, & Building Exterior	7,891	83,575	5.0
Residential	Building Equipment Contractors	18,108	125,559	8.5
Residential	Building Finishing Contractors	17,942	133,260	8.0
Commercial	All	17,621	368,810	35.0
Commercial	Building Construction Contractors	4,919	83,028	9.0
Commercial	Foundation, Structure, & Building Exterior	2,194	59,110	5.0
Commercial	Building Equipment Contractors	6,039	139,442	13.5
Commercial	Building Finishing Contractors	4,469	87,230	7.4
Industrial, Utilities, Infrastructure, & Other (Industrial+)	All	4,206	101,002	11.4
Industrial+	Building Construction	288	3,995	0.4
Industrial+	Utility System Construction	1,761	50,126	5.5
Industrial+	Land Subdivision	907	6,550	1.0
Industrial+	Highway, Street, and Bridge Construction	799	28,726	3.1
Industrial+	Other Heavy Construction	451	11,605	1.4

Source: (State of California n.d.)

The proposed change to exhaust fan controls would likely affect commercial builders but would not impact firms that focus on construction and retrofit of industrial buildings, utility systems, public infrastructure, or other heavy construction. The effects on the commercial building industry would not be felt by all firms and workers, but rather would be concentrated in specific industry subsectors. Table 3 shows the commercial building subsectors the Statewide CASE Team expects to be impacted by the changes proposed in this report. Exhaust fan controls would impact only the HVAC contractors. The Statewide CASE Team’s estimates of the magnitude of these impacts are shown in Section 2.2.4 Economic Impacts.

Table 38: Specific Subsectors of the California Commercial Building Industry Impacted by Proposed Change to Code/Standard by Subsector in 2022 (Estimated)

Construction Subsector	Establishments	Employment	Annual Payroll (Billions \$)
Nonresidential plumbing & HVAC contractors	2,346	55,572	5.5

Source: (State of California n.d.)

4.2.3.2 Impact on Building Designers and Energy Consultants

Adjusting design practices to comply with changing building codes is within the normal practices of building designers. Building codes (including Title 24, Part 6) are typically updated on a three-year revision cycle, and building designers and energy consultants engage in continuing education and training to remain compliant with changes to design practices and building codes.

Businesses that focus on residential, commercial, institutional, and industrial building design are contained within the Architectural Services sector (North American Industry Classification System 541310). Table 4 shows the number of establishments, employment, and total annual payroll for Building Architectural Services. The proposed code changes would potentially impact all firms within the Architectural Services sector. The Statewide CASE Team anticipates the impacts for exhaust fan controls to affect firms that focus on nonresidential construction.

There is not a North American Industry Classification System (NAICS)²³ code specific to energy consultants. Instead, businesses that focus on consulting related to building

²³ NAICS is the standard used by federal statistical agencies in classifying business establishments for the purpose of collecting, analyzing, and publishing statistical data related to the U.S. business economy. NAICS was developed jointly by the U.S. Economic Classification Policy Committee (ECPC), Statistics Canada, and Mexico's Instituto Nacional de Estadística y Geografía, to allow for a high level of comparability in business statistics among the North American countries. NAICS replaced the Standard Industrial Classification (SIC) system in 1997.

energy efficiency are contained in the Building Inspection Services sector (NAICS 541350), which is comprised of firms primarily engaged in the physical inspection of nonresidential buildings.²⁴ It is not possible to determine which business establishments within the Building Inspection Services sector are focused on energy efficiency consulting. The information shown in Table 39 provides an upper bound indication of the size of this sector in California.

Table 39: California Building Designer and Energy Consultant Sectors in 2022 (Estimated)

Sector	Establishments	Employment	Annual Payroll (Millions \$)
Architectural Services^a	4,134	31,478	3,623.3
Building Inspection Services^b	1,035	3,567	280.7

Source: (State of California n.d.)

- a. Architectural Services (NAICS 541310) comprises private-sector establishments primarily engaged in planning and designing residential, institutional, leisure, commercial, and industrial buildings and structures.
- b. Building Inspection Services (NAICS 541350) comprises private-sector establishments primarily engaged in providing building (residential & nonresidential) inspection services encompassing all aspects of the building structure and component systems, including energy efficiency inspection services.

4.2.3.3 Impact on Occupational Safety and Health

The proposed code change does not alter any existing federal, state, or local regulations pertaining to safety and health, including rules enforced by the California Division of Occupational Safety and Health (DOSH). All existing health and safety rules would remain in place. Complying with the proposed code change is not anticipated to have adverse impacts on the safety or health of occupants or those involved with the construction, commissioning, and maintenance of the building.

4.2.3.4 Impact on Building Owners and Occupants

Commercial Buildings

The commercial building sector includes a wide array of building types, including offices, restaurants and lodging, retail, and mixed-use establishments, and warehouses (including refrigerated) (Kenney 2019). Energy use by occupants of commercial buildings also varies considerably, with electricity used primarily for lighting, space

²⁴ Establishments in this sector include businesses primarily engaged in evaluating a building's structure and component systems and includes energy efficiency inspection services and home inspection services. This sector does not include establishments primarily engaged in providing inspections for pests, hazardous wastes or other environmental contaminants, nor does it include state and local government entities that focus on building or energy code compliance/enforcement of building codes and regulations.

cooling and conditioning, and refrigeration, while natural gas is used primarily for water heating and space heating. According to information published in the 2019 California Energy Efficiency Action Plan, there is more than 7.5 billion square feet of commercial floor space in California consuming 19 percent of California’s total annual energy use (Kenney 2019). The diversity of building and business types within this sector creates a challenge for disseminating information on energy and water efficiency solutions, as does the variability in sophistication of building owners and the relationships between building owners and occupants.

Estimating Impacts

Building owners and occupants would benefit from lower energy bills. As discussed in Section 2.2.4.1, when building occupants save on energy bills, they tend to spend it elsewhere in the economy thereby creating jobs and economic growth for the California economy. The Statewide CASE Team does not expect the proposed code change for the 2025 code cycle to impact building owners or occupants adversely.

4.2.3.5 Impact on Building Component Retailers (Including Manufacturers and Distributors)

The Statewide CASE Team anticipates the proposed change would have no material impact on California component retailers.

4.2.3.6 Impact on Building Inspectors

Table 40 shows employment and payroll information for state and local government agencies in which many inspectors of residential and commercial buildings are employed. Building inspectors participate in continuing education and training to stay current on all aspects of building regulations, including energy efficiency. The Statewide CASE Team, therefore, anticipates the proposed change would have no impact on employment of building inspectors or the scope of their role conducting energy efficiency inspections.

Table 40: Employment in California State and Government Agencies with Building Inspectors in 2022 (Estimated)

Sector	Govt.	Establishments	Employment	Annual Payroll (Million \$)
Administration of Housing Programs ^a	State	18	265	29.0
	Local	38	3,060	248.6
Urban and Rural Development Admin ^b	State	38	764	71.3
	Local	52	2,481	211.5

Source: (State of California, Employment Development Department n.d.)

- a. Administration of Housing Programs (NAICS 925110) comprises government establishments primarily engaged in the administration and planning of housing programs, including building codes and standards, housing authorities, and housing programs, planning, and development.
- b. Urban and Rural Development Administration (NAICS 925120) comprises government establishments primarily engaged in the administration and planning of the development of urban and rural areas. Included in this industry are government zoning boards and commissions.

4.2.3.7 Impact on Statewide Employment

As described in Sections 2.2.3.1 through 2.2.3.6, the Statewide CASE Team does not anticipate significant employment or financial impacts to any particular sector of the California economy. This is not to say that the proposed change would not have modest impacts on employment in California. In Section 2.2.4, the Statewide CASE Team estimated the proposed change in exhaust fan control would affect statewide employment and economic output directly and indirectly through its impact on builders, designers and energy consultants, and building inspectors. In addition, the Statewide CASE Team estimated how energy savings associated with the proposed change in exhaust fan control would lead to modest ongoing financial savings for California residents, which would then be available for other economic activities.

4.2.4 Economic Impacts

For the 2025 code cycle, the Statewide CASE Team used the IMPLAN model software,²⁵ along with economic information from published sources, and professional judgement to develop estimates of the economic impacts associated with each of the proposed code changes. Conceptually, IMPLAN estimates jobs created as a function of incoming cash flow in different sectors of the economy, due to implementing a code or a standard. The jobs created are typically categorized into direct, indirect, and induced employment. For example, cash flow into a manufacturing plant captures direct employment (jobs created in the manufacturing plant), indirect employment (jobs created in the sectors that provide raw materials to the manufacturing plant) and induced employment (jobs created in the larger economy due to purchasing habits of people newly employed in the manufacturing plant). Eventually, IMPLAN computes the total number of jobs created due to a code. The assumptions of IMPLAN include constant returns to scale, fixed input structure, industry homogeneity, no supply constraints, fixed technology, and constant byproduct coefficients. The model is also static in nature and is a simplification of how jobs are created in the macro-economy.

The economic impacts developed for this report are only estimates and are based on limited and to some extent speculative information. The IMPLAN model provides a relatively simple representation of the California economy and, though the Statewide

²⁵ IMPLAN employs economic data and advanced economic impact modeling to estimate economic impacts for interventions like changes to the California Title 24, Part 6 code. For more information on the IMPLAN modeling process, see www.IMPLAN.com.

CASE Team is confident that the direction and approximate magnitude of the estimated economic impacts are reasonable, it is important to understand that the IMPLAN model is a simplification of extremely complex actions and interactions of individual, businesses, and other organizations as they respond to changes in energy efficiency codes. In all aspects of this economic analysis, the CASE Authors rely on conservative assumptions regarding the likely economic benefits associated with the proposed code change. By following this approach, the economic impacts presented below represent lower bound estimates of the actual benefits associated with this proposed code change.

Adoption of this code change proposal would result in relatively modest economic impacts through the additional direct spending by those in the commercial building industry, architects, energy consultants, and building inspectors. The Statewide CASE Team does not anticipate that money saved by commercial building owners or other organizations affected by the proposed 2025 code cycle regulations would result in additional spending by those businesses.

Table 41: Estimated Impact that Adoption of the Proposed Measure would have on the California Building Designers and Energy Consultants Sectors

Impact Type	Employment	Labor Income	Value Added	Output
Direct Effect	0.0	\$160	\$159	\$251
Indirect Effect	0.0	\$48	\$66	\$107
Induced Effect	0.0	\$60	\$107	\$170
Total Effect	0.0	\$268	\$332	\$528

Source: Statewide CASE Team analysis of data from the IMPLAN modeling software.

Table 42: Estimated Impact that Adoption of the Proposed Measure would have on California Building Inspectors

Impact Type	Employment	Labor Income	Value Added	Output
Direct Effect	0.0	\$27	\$32	\$39
Indirect Effect	0.0	\$2	\$4	\$7
Induced Effect	0.0	\$8	\$15	\$24
Total Effect	0.0	\$38	\$51	\$70

Source: Statewide CASE Team analysis of data from the IMPLAN modeling software.

4.2.4.1 Creation or Elimination of Jobs

The Statewide CASE Team does not anticipate that the measures proposed for the 2025 code cycle regulation would lead to the creation of new *types* of jobs or the elimination of *existing* types of jobs. In other words, the Statewide CASE Team’s

proposed change would not result in economic disruption to any sector of the California economy. Rather, the estimates of economic impacts discussed in Section 2.2.4 would lead to modest changes in employment of existing jobs.

4.2.4.2 Creation or Elimination of Businesses in California

As stated in Section 2.2.4.1, the Statewide CASE Team’s proposed change would not result in economic disruption to any sector of the California economy. The proposed change represents a modest change to fan control compliance pathways, which would not excessively burden or competitively disadvantage California businesses – nor would it necessarily lead to a competitive advantage for California businesses. Therefore, the Statewide CASE Team does not foresee any new businesses being created, nor does the Statewide CASE Team think any existing businesses would be eliminated due to the proposed code changes.

4.2.4.3 Competitive Advantages or Disadvantages for Businesses in California

The proposed code changes would apply to all businesses incorporated in California, regardless of whether the business is located inside or outside of the state.²⁶ Therefore, the Statewide CASE Team does not anticipate that these measures proposed for the 2025 code cycle regulation would have an adverse effect on the competitiveness of California businesses. Likewise, the Statewide CASE Team does not anticipate businesses located outside of California would be advantaged or disadvantaged.

4.2.4.4 Increase or Decrease of Investments in the State of California

The Statewide CASE Team analyzed national data on corporate profits and capital investment by businesses that expand a firm’s capital stock (referred to as net private domestic investment, or NPDI).²⁷ As Table 43 shows, between 2017 and 2021, NPDI as a percentage of corporate profits ranged from a low of 18 in 2020 due to the worldwide economic slowdowns associated with the COVID 19 pandemic to a high of 35 percent in 2019, with an average of 26 percent. While only an approximation of the proportion of business income used for net capital investment, the Statewide CASE Team believes it provides a reasonable estimate of the proportion of proprietor income that would be reinvested by business owners into expanding their capital stock.

²⁶ Gov. Code, §§ 11346.3(c)(1)(C), 11346.3(a)(2); 1 CCR § 2003(a)(3) Competitive advantages or disadvantages for California businesses currently doing business in the state.

²⁷ Net private domestic investment is the total amount of investment in capital by the business sector that is used to expand the capital stock, rather than maintain or replace due to depreciation. Corporate profit is the money left after a corporation pays its expenses.

Table 43: Net Domestic Private Investment and Corporate Profits, U.S.

Year	Net Domestic Private Investment by Businesses, Billions of Dollars	Corporate Profits After Taxes, Billions of Dollars	Ratio of Net Private Investment to Corporate Profits (Percent)
2017	518.473	1882.460	28
2018	636.846	1977.478	32
2019	690.865	1952.432	35
2020	343.620	1908.433	18
2021	506.331	2619.977	19
5-Year Average	-	-	26

Source: (Federal Reserve Economic Data (FRED) n.d.)

The Statewide CASE Team does not anticipate that the economic impacts associated with the proposed measure would lead to significant change (increase or decrease) in investment, directly or indirectly, in any affected sectors of California’s economy. Nevertheless, the Statewide CASE Team is able to derive a reasonable estimate of the change in investment by California businesses based on the estimated change in economic activity associated with the proposed measure and its expected effect on proprietor income, which the Statewide CASE Team uses a conservative estimate of corporate profits, a portion of which the Statewide CASE Team assumes will be allocated to net business investment.²⁸

4.2.4.5 Incentives for Innovation in Products, Materials, or Processes

By offering another compliance pathway that does not require complex feedback loops or sensors, this measure may allow for more inexpensive options to emerge on the market, spurring additional investments elsewhere.

4.2.4.6 Effects on the State General Fund, State Special Funds, and Local Governments

The Statewide CASE Team does not expect the proposed code changes would have a measurable impact on California’s General Fund, any state special funds, or local government funds.

Cost of Enforcement

Cost to the State: State government already has budget for code development, education, and compliance enforcement. While state government will be allocating resources to update the Title 24, Part 6 Standards, including updating education and compliance materials and responding to questions about the revised requirements, these activities are already covered by existing state budgets. The costs to state

²⁸ 26 percent of proprietor income was assumed to be allocated to net business investment; see Table 9.

government are small when compared to the overall costs savings and policy benefits associated with the code change proposals. This option does not make any new requirements or changes, but allows for another option in fan controls, and thus would not have any negative impact overall to the state.

Cost to Local Governments: All proposed code changes to Title 24, Part 6 would result in changes to compliance determinations. Local governments would need to train building department staff on the revised Title 24, Part 6 Standards. While this retraining is an expense to local governments, it is not a new cost associated with the 2025 code change cycle. The building code is updated on a triennial basis, and local governments plan and budget for retraining every time the code is updated. There are numerous resources available to local governments to support compliance training that can help mitigate the cost of retraining, including tools, training and resources provided by the IOU Codes and Standards program (such as Energy Code Ace). As noted in Section 2.1.5 and Appendix E, the Statewide CASE Team considered how the proposed code change might impact various market actors involved in the compliance and enforcement process and aimed to minimize negative impacts on local governments.

4.2.4.7 Impacts on Specific Persons

While the objective of any of the Statewide CASE Team’s proposal is to promote energy efficiency, the Statewide CASE Team recognizes that there is the potential that a proposed code change may result in unintended consequences. The fan controls measure is adding another option rather than replacing or restricting an existing option, and thus is not expected to have any negative unintended impacts or consequences. Refer to Section **Error! Reference source not found.** for more details addressing energy equity and environmental justice.

4.2.5 Fiscal Impacts

4.2.5.1 Mandates on Local Agencies or School Districts

This measure may impact any schools or local agencies that have labs slated for new construction. However this measure adds flexibility by adding an additional control method instead of the low fan power base option.

4.2.5.2 Costs to Local Agencies or School Districts

This measure does not require any new or novel technologies to be implemented but instead offers a simpler option for fan controls, and thus there are no significant additional costs expected to local agencies or school districts.

4.2.5.3 Costs or Savings to Any State Agency

There are no costs or savings to any state agency except in operating costs, due to the energy savings to be had in implementing this measure.

4.2.5.4 Other Non-Discretionary Cost or Savings Imposed on Local Agencies

There are no added non-discretionary costs or savings to local agencies as this would not impact non-discretionary funds.

4.2.5.5 Costs or Savings in Federal Funding to the State

There are no costs or savings to federal funding to the state as this measure does not infringe or otherwise touch upon any federal funds associated with this measure.

4.3 Energy Savings

4.3.1 Energy Savings Methodology

4.3.1.1 Key Assumptions for Energy Savings Analysis

The primary energy savings from the simple turndown control method result from a combination of fan control and exhaust system geometry. The system must be able to reduce the volumetric flow rate of air and exhaust gases entering the exhaust fan to a minimum flow rate that is no greater than 60 percent of the system design flow rate entering the exhaust fan. This reduced fan flow rate is determined by simulations or scale models that calculate the worst-case concentrations at locations where the public might be exposed to the exhaust gases. These simulated concentrations are conducted for wind speeds up to the ASHRAE one percent wind speed (only 87 hours per year are the wind speeds higher) and for multiple wind directions.

For the base case (Standard Design) technology, it is assumed that the volumetric stack design exhaust rate is maintained for all hours even when the amount of air exhausted from the laboratory is reduced. This is accomplished by the use of a bypass damper that opens and adds additional air to the air stream leaving the exhaust stack when the exhaust air from the lab is less than its design flow rate. Almost all hours of the year require bypass air to maintain the design stack flow rate.

For the proposed case (Proposed Design) control, when the exhaust rate from the laboratory is between the design flow rate and 60 percent of the design flow rate, no bypass air is needed as the system is able to reduce fan flow rate safely down to 60 percent of design airflow rate. Not all systems can safely reduce to 60 percent of design airflow rate, but this is a criterion required to use the control. This is validated by the system designer and physical dispersion modelling specialist making use of simulation tools and/or scale models. The designer would need to provide documentation that the

system can safely reduce fan system airflow to 60 percent of design airflow or less. For the minimally compliant system modelled, when the exhaust air volume is reduced to below 60 percent of the fan system design airflow rate, then the bypass damper opens to maintain 60 percent of the design airflow rate. The system could be designed for the minimum exhaust fan flow rate to be less than 60 percent of design airflow rate, but the calculations here are for a minimally compliant system with a minimum exhaust fan airflow rate of 60 percent of the design flow rate.

The primary savings from the simplified fan control is fan energy. The calculation methodology was a spreadsheet calculation of energy savings per cfm of the design rating of the exhaust system and then the results were used to inform a CBECC simulation of the system. The analysis adjusted the CBECC prototype from a three-story building with mixed office and lab spaces to a one-story building with all lab spaces. This was done to focus the savings analysis solely on lab spaces without interactions from other office spaces, as the proposed measures target lab spaces only. The outside air in the model was also adjusted to six air changes at all times.

The fan energy unit savings spreadsheet was predicated on the following assumptions:

- The base case fan power would be 0.65 W/cfm at design flow rate.
- The proposed case fan power (simplified fan control) would be 1.30 W/cfm at design flow rate.
- Lab exhaust flows are the same for the base case and the proposed case. The volume of air leaving the laboratory is a function of the lab interior exhaust systems controls. Static pressure, fume hood exhaust damper controls combine to provide minimum air changes per hour (ACH) for the lab and modulate to provide sufficient additional volume when needed to accommodate airflow needed for fume hood operation, or for sufficient airflow for heating or cooling.
- When additional airflow beyond that from the lab exhaust flow is needed to maintain the minimum safe airflow through the exhaust fan, a by-pass damper provides enough additional air for the difference between the needed fan airflow and the lab exhaust airflow. The primary difference between the base case and proposed case is the minimum fan airflow. The base case fan airflow is the 100 percent of the design airflow and proposed case minimum fan airflow is 60 percent of the design airflow.
- The fan power at any flow rate is the greater of 40 percent of the design fan power and the design fan power times the square of the stack airflow rate.²⁹

²⁹ Because the fan systems is trying to maintain a constant static pressure in parts of the duct work a conservative approach is to treat fan power as a square of the fan speed instead of the cube of the fan speed as predicted by the “affinity laws” see: <https://www.aircuity.com/blog/using-the-lab-roi-tool-to-calculate-vav-exhaust-fan-control-savings/>

- We assumed that the design minimum outside airflow rate was 6 ACH during the day and 4 ACH at night/unoccupied. Given that the daytime minimum was 6 ACH, the design ACH would be $6 \text{ ACH} / 0.60 = 10 \text{ ACH}$. This is assuming a 10-foot ceiling.
- Day/occupied is when the occupancy fraction is greater than five percent in the schedules profile in the 2022 Nonresidential ACM Reference Manual Appendix 5.4B. Unoccupied is when the occupancy fraction is five percent or less.
- The design cooling flow was 80 percent of the design airflow or 8 ACH.
- The laboratory exhaust flow rate was the greater of a) hood airflow fraction (manual hood control) times the design airflow rate b) the receptacle fraction times the design cooling flow, and c) the minimum ACH. The scheduled fractions are from 2022 Nonresidential ACM Reference Manual Appendix 5.4B.
- The stack flow rate was the greater of the laboratory exhaust flow rate and the minimum stack flow rate. For the base case the minimum stack airflow rate was assumed to be the design stack flow rate. The proposed base is minimally compliant and thus the minimum stack flow rate was 60 percent of the design stack flow rate. In contrast to the proposed 60 percent flow rate, the base case had a stack flow rate that was 100 percent of the designed flow rate at all hours.
- The cooling loads and the diversified fume hood loads never exceeded the minimum required ACH, except at night. For the proposed case, the minimum stack flow rate was 60 percent of the design air flow rate; thus, even though the lab flow rate dropped at night to below 60 percent of fan design flow rate, the bypass damper was activated to maintain sufficient leaving velocity from the stack at 60 percent of flow. The base case design ran at 100 percent of stack design flow for all hours. However, reductions in lab exhaust flow in both base and proposed cases result in thermal energy savings relative to a constant volume lab exhaust system.
- As a result, the base case fan energy for 10 ACH at 0.65 W/cfm is greater than the fan energy for 60 percent of 10 ACH (6 ACH) at 40 percent rated power of the design fan efficacy of 1.3 W/cfm (i.e., 0.52 W/design cfm or 0.87 W/actual cfm).
- For the 17,876 square feet of laboratory space in the prototype model, the proposed control saves 1.71 kWh/yr- ft². The summary statistics are contained in Table 44.

Table 44: Prototype Building: Simplified Controls Energy Consumption Comparison

Description	Base Case	Proposed	Savings
Energy (kWh/yr)	152,679	122,143	30,536
Energy (kWh/yr- ft ²)	8.54	6.83	1.71
Energy (kWh/yr-cfm)	5.69	4.56	1.14

4.3.1.2 Energy Savings Methodology per Prototypical Building

The Statewide CASE Team measured per-unit energy savings expected from the proposed code changes in several ways to quantify key impacts. First, savings are calculated by fuel type. Electricity savings are measured in terms of both energy usage and peak demand reduction. Natural gas savings are quantified in terms of energy usage. Second, the Statewide CASE Team calculated source energy savings. Source energy represents the total amount of raw fuel required to operate a building. In addition to all energy used from on-site production, source energy incorporates all transmission, delivery, and production losses. The hourly source energy values provided by CEC are proportional to GHG emissions. Finally, the Statewide CASE Team calculated Long-term Systemwide Cost (LSC) savings, formerly known as Time Dependent Value (TDV) energy cost savings. LSC savings are calculated using hourly energy cost metrics for both electricity and natural gas provided by the CEC. These LSC hourly factors are projected over the 30-year life of the building. The LSC hourly factors incorporate the hourly cost of marginal generation, transmission and distribution, fuel, capacity, losses, and cap-and-trade-based CO₂ emissions (California Energy Commission 2022).

The CEC directed the Statewide CASE Team to model the energy impacts using specific prototypical building models that represent typical building geometries for different types of buildings. They also estimate the amount of total existing building stock in 2026, which the Statewide CASE Team used to approximate savings from building alteration (California Energy Commission 2022, California Energy Commission 2022). The prototype buildings that the Statewide CASE Team used in the analysis are presented in Table 45.

Table 45: Prototype Buildings Used for Energy, Demand, Cost, and Environmental Impacts Analysis

Prototype Name	Number of Stories	Floor Area (Square Feet)	Description
Lab Only Single Story	1	17,876	One story office building with 5 zones and a ceiling plenum on each floor. WWR-0.33

The Statewide CASE Team estimated LSC energy, source energy, electricity, natural gas, peak demand, and GHG impacts by simulating the proposed code change using a spreadsheet that modelled a 17,876 square foot laboratory space with the assumptions described in the prior section. Unlike the CEC Medium Office laboratory prototype, this prototype does not include any office space.

The Proposed Design was identical to the Standard Design in all ways except for the revisions that represent the proposed changes to the code. Section 4.3.1.1 presents which parameters were modified and what values were used in the Standard Design and Proposed Design. The proposed conditions assume a variable speed fan exhaust fan that reduces its speed when the sum of the laboratory zone exhaust air is reduced down to the minimum exhaust fan airflow rate and does not use the bypass damper air until sum of the laboratory zone exhaust air is lower than the minimum exhaust fan airflow rate.

The energy Impacts of the proposed code change do not vary by climate zone. Since savings do not vary by climate zone, the Statewide CASE Team used the statewide average LSC hourly factors when calculating energy and energy cost impacts.

Per-unit energy impacts for nonresidential buildings are presented in savings per square foot. Annual energy, GHG, and peak demand impacts for each prototype building were translated into impacts per square foot by dividing by the floor area of the prototype building. This step allows for an easier comparison of savings across different building types and enables a calculation of statewide savings using the construction forecast that is published in terms of floor area by building type.

4.3.1.3 Statewide Energy Savings Methodology

The per-unit energy impacts were extrapolated to statewide impacts using the statewide construction forecasts that the CEC provided. The statewide construction forecasts estimate new construction/additions that would occur in 2026, the first year that the 2025 Title 24, Part 6 requirements are in effect (California Energy Commission 2022). They also estimate the amount of total existing building stock in 2026, which the Statewide CASE Team used to approximate savings from building alterations. The construction forecast provides construction (new construction/additions and existing building stock) by building type and climate zone.

The statewide energy savings calculated here assume that approximately 10 percent of systems would use the simplified control approach. The reason for such a low market fraction is the expense associated with a contaminant dispersion study that would help justify the reduction in stack flow rate to 60 percent of less while maintaining safe contaminant concentrations in the outdoor areas around the lab exhaust.

Appendix A presents additional information about the methodology and assumptions used to calculate statewide energy impacts.

4.3.2 Per-Unit Energy Impacts Results

Energy savings and peak demand reductions per unit are presented in Table 46. The presented savings are for new construction. The per-unit energy savings figures do not account for naturally occurring market adoption or compliance rates. Per-unit savings for the first year are expected to be 1.71 kWh/ft². Demand reductions are expected to be 0.2 kW ft².

Table 46: First-Year Energy Impacts Per Square Foot-- Exhaust Fan Control

Climate Zone	All Climate Zones
First-Year Electricity Savings (kWh)	1.71
First-Year Peak Demand Reduction (kW)	0.2
First-Year Natural Gas Savings (kBtu)	-
First-Year Source Energy Savings (kBtu)	8.7
LSC Savings	-

4.4 Cost and Cost Effectiveness

The code change proposal would not modify the stringency of the existing California Energy Code, so the CEC does not need a complete cost-effectiveness analysis to approve the proposed change. For this proposed change, the Statewide CASE Team is presenting information on the cost implications in lieu of a full cost-effectiveness analysis.

4.5 First-Year Statewide Impacts

The code change proposal would not modify the stringency of the existing California Energy Code, so the savings associated with this proposed change are minimal. Typically, the Statewide CASE Team presents a detailed analysis of statewide energy and cost savings associated with the proposed change in Section 3.5 of the Draft CASE Report. As discussed in Section 3.3, although the energy savings are limited, the measure would promote.

4.5.1 Statewide Energy and Energy Cost Savings

The Statewide CASE Team calculated the first-year statewide savings for new construction and additions by multiplying the per-unit savings, which are presented in Section 4.3.2, by assumptions about the percentage of newly constructed buildings that would be impacted by the proposed code. The statewide new construction forecast for 2026 is presented in Appendix A, as are the Statewide CASE Team's assumptions about the percentage of new construction that would be impacted by the proposal (by climate zone and building type).

The Statewide CASE Team calculated the statewide impacts by multiplying the per-unit energy savings by the 2026 new construction forecast for labs. The first-year energy impacts represent the first-year annual savings from all buildings that were completed in 2026. The 30-year energy cost savings represent the energy cost savings over the entire 30-year analysis period. The statewide savings estimates do not take naturally occurring market adoption or compliance rates into account.

Table 47 presents the first-year statewide energy and energy cost savings from newly constructed buildings, additions, and alterations.

Table 47: Statewide Energy and Energy Cost Impacts – New Construction and Additions

Climate Zone	Statewide Floorspace Impacted by Proposed Change in 2026 (Million Square Feet)	First-Year ^a Electricity Savings (GWh)	First-Year Peak Electrical Demand Reduction (MW)	First-Year Natural Gas Savings (Million Therms)	First-Year Source Energy Savings (Million kBtu)	30-Year Present Valued Energy Cost Savings (Million 2026 PV\$)
New Construction and Additions	396,342	0.68	0.08	-	1.15	\$3.81
Alterations	1,206,556	2.06	0.24	-	3.51	\$11.61

a. First-year savings from all buildings completed statewide in 2026.

4.5.2 Statewide Greenhouse Gas (GHG) Emissions Reductions

The Statewide CASE Team calculated avoided GHG emissions associated with energy consumption using the hourly GHG emissions factors that CEC developed along with the 2025 LSC hourly factors and an assumed cost of \$123.15 per metric tons of carbon dioxide equivalent emissions (metric tons CO₂e).

The 2025 LSC hourly factors used in the lifecycle cost-effectiveness analysis include the monetary value of avoided GHG emissions based on a proxy for permit costs (not social costs).³⁰ The cost-effectiveness analysis presented in Section 4.4 of this report does not include the cost savings from avoided GHG emissions. To demonstrate the cost savings of avoided GHG emissions, the Statewide CASE Team disaggregated the value of avoided GHG emissions from the other economic impacts. The authors used the same monetary values that are used in the LSC hourly factors.

³⁰ The permit cost of carbon is equivalent to the market value of a unit of GHG emissions in the California Cap-and-Trade program, while social cost of carbon is an estimate of the total economic value of damage done per unit of GHG emissions. Social costs tend to be greater than permit costs. See more on the Cap-and-Trade Program on the California Air Resources Board website: <https://ww2.arb.ca.gov/our-work/programs/cap-and-trade-program>.

Table 48 presents the estimated first-year avoided GHG emissions of the proposed code change. During the first year, GHG emissions of 4 (metric tons CO₂e) would be avoided.

Table 48: First-Year Statewide GHG Emissions Impacts

Measure	Electricity Savings ^a (GWh/yr)	Reduced GHG Emissions from Electricity Savings ^a (Metric Tons CO ₂ e)	Natural Gas Savings ^a (Million Therms/yr)	Reduced GHG Emissions from Natural Gas Savings ^a (Metric Tons CO ₂ e)	Total Reduced GHG Emissions ^a (Metric Ton CO ₂ e)	Total Monetary Value of Reduced GHG Emissions ^b (\$)
Exhaust Fan Control	3	247	0.00	0	247	30,409

- a. First-year savings from all buildings completed statewide in 2026.
- b. GHG emissions factors are included in the LSC hourly factors published by CEC (California Energy Commission 2022).

4.5.3 Statewide Water Use Impacts

The proposed code change would not result in water savings.

4.5.4 Statewide Material Impacts

The proposed code change would not result in material impacts.

5. Reheat Limitation (4-Pipe VAV)

5.1 Measure Description

5.1.1 Proposed Code Change

The proposed code change would add a new requirement in section 140.9 (prescriptive requirements for laboratories) that would eliminate reheat in most labs. The proposed change will not prevent any labs from meeting any special pressurization or cross contamination or humidity control or high exhaust requirements.

- **Type of change:** Prescriptive
- **Building types impacted:** Buildings with laboratory spaces. Occupancy Classifications that may include laboratory spaces include:
 - Business Group B
 - Educational Group E
 - Laboratories Group L
- **Threshold:** The proposal would apply to laboratory spaces of any size. Title 24 defines laboratory spaces as follows:

Laboratory, Scientific Area is a room or area where research, experiments, and measurement in medical and physical sciences are performed requiring examination of fine details. The area may include workbenches, countertops, scientific instruments, and associated floor spaces. Scientific laboratory does not refer to film, computer, and other laboratories where scientific experiments are not performed.

- **Additions/Alterations:** The proposal would not apply to additions or alterations of existing systems that do not already meet the proposal. The proposal would apply if the space is already served by a system that meets the proposal or the space will be served by new supply and exhaust systems.
- **Field Verification / Acceptance Tests:** No changes required.
- **Compliance Software Updates:** No updates are required to the software, as EnergyPlus already has the ability to model 4-pipe VAV (please confirm). The ACM rules will be updated to make 4-pipe VAV the baseline system for labs.
- **Newly Regulated System or Technology?** This proposal does not add requirements for a system or technology that was not regulated previously.

Here is a [hyperlink to proposed language for reheat limitation](#).

5.1.2 Justification and Background Information

5.1.2.1 Justification

4-pipe VAV systems are common in labs. Chilled beams and VRF, both of which can also meet the proposed requirement, are also common in labs.

These are not the lowest cost systems for labs. A 2-pipe VAV system is less expensive than a 4-pipe system, at least for labs with gas boilers. A 4-pipe VAV system will have dramatically lower energy use than a 2-pipe system and is lifecycle cost effective.

Heat recovery (as proposed above in Section 3) and minimizing reheat with 4-pipe VAV (as proposed here) are not mutually exclusive. The energy savings of heat recovery are not affected by minimizing reheat and vice versa.

More justification and background can be found in this [ASHRAE Journal Article on 4-Pipe VAV vs. Active Chilled Beams for Labs](#).

5.1.2.2 Background Information

Section 140.4(d) prescriptively prohibits reheating more than the design zone outdoor airflow rate in the dead band between heating and cooling and in the first stage of heating. The Title 24 minimum ventilation rate for labs is 0.15 cfm/ft². Section 140.4(d) has 5 exceptions including Exception 1 for zones with special pressurization or cross contamination needs and Exception 3 for humidity controls. Many labs use Exception 1 or 3 to justify reheating far more than 0.15 cfm/ft². Labs commonly have minimum flow rates (and thus reheat rates) on the order of 4 to 6 ACH which is about 0.6 to 1.0 cfm/ft².

The proposed change would effectively limit the types of mechanical systems labs can use. A common type of lab system is 2-pipe VAV reheat (see Figure 8). With this system a multiple-zone air handler cools the outside air (e.g., from 80°F to 55°F) and then the 2-pipe hot water zone coil reheats the air (e.g., 1.0 cfm/ft² from 55°F to 70°F) to maintain space temperature.

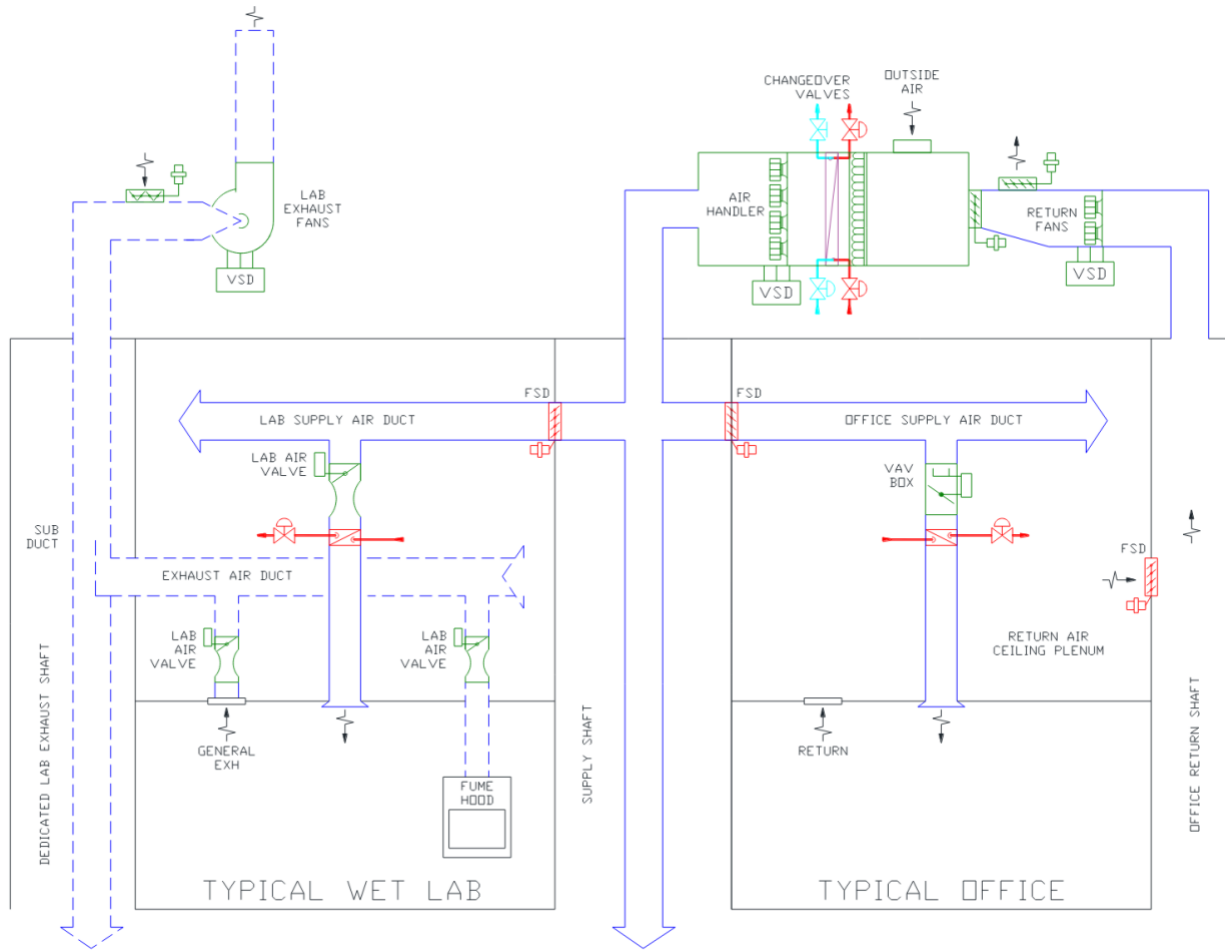

Figure 8: 2-Pipe VAV lab schematic.

Another type of lab mechanical system is 4-pipe VAV (Figure 9 and Figure 10). This system is similar to a 2-pipe VAV reheat system, but the lab zone coils have both hot water and chilled water connections (thus 4-pipe). This means the central air handler does not need to do any cooling because all cooling can be done at the zone level. This system eliminates reheat. 4-pipe VAV is not the only system type that would meet this new requirement. Other systems include chilled beams, VRF, and separate cooling and heating coils at each zone, i.e., two 2-pipe coils, rather than one 4-pipe coil. Figure 11 through Figure 14 present additional schematics for typical 4-pipe systems.

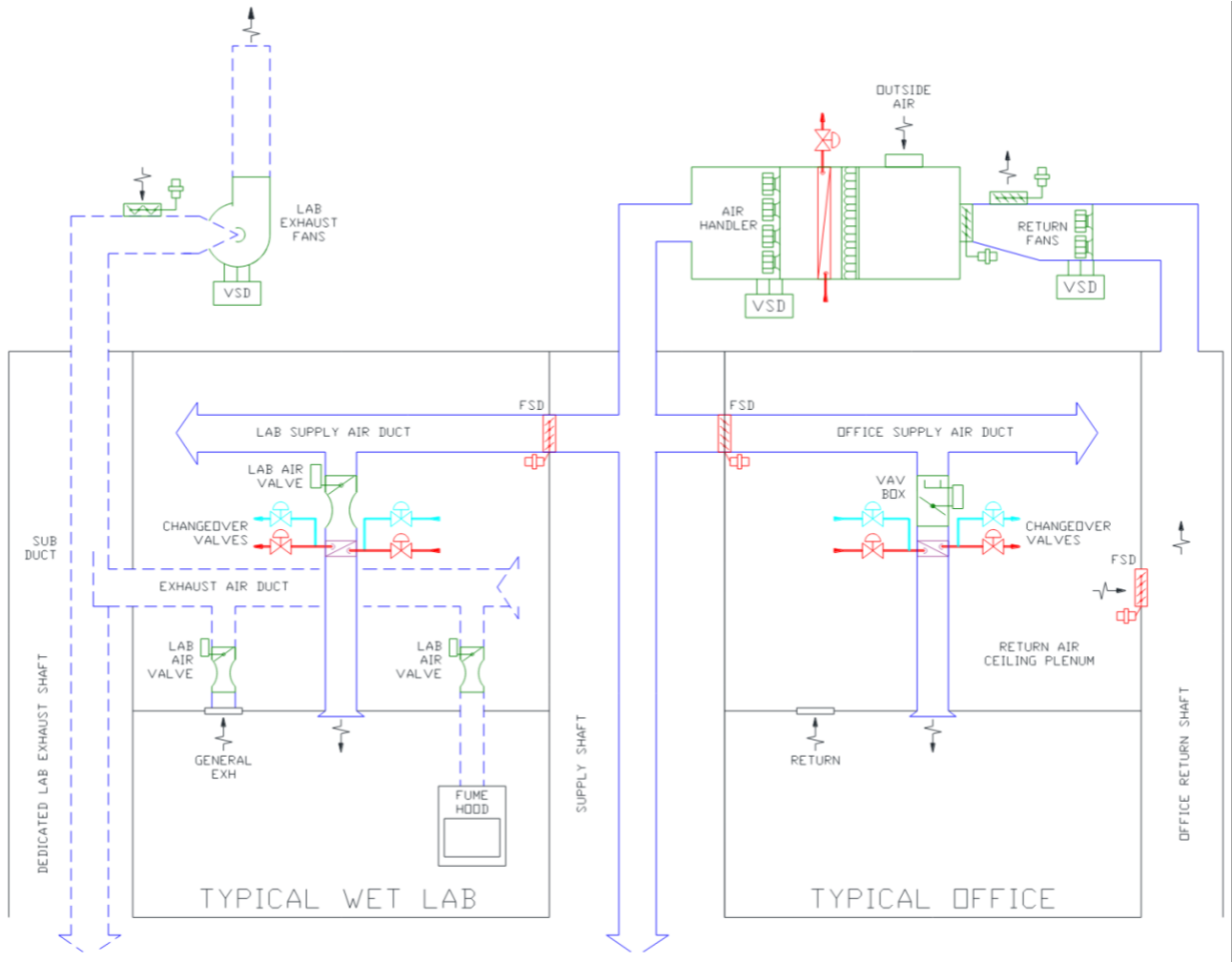

Figure 9: 4-Pipe VAV lab schematic.

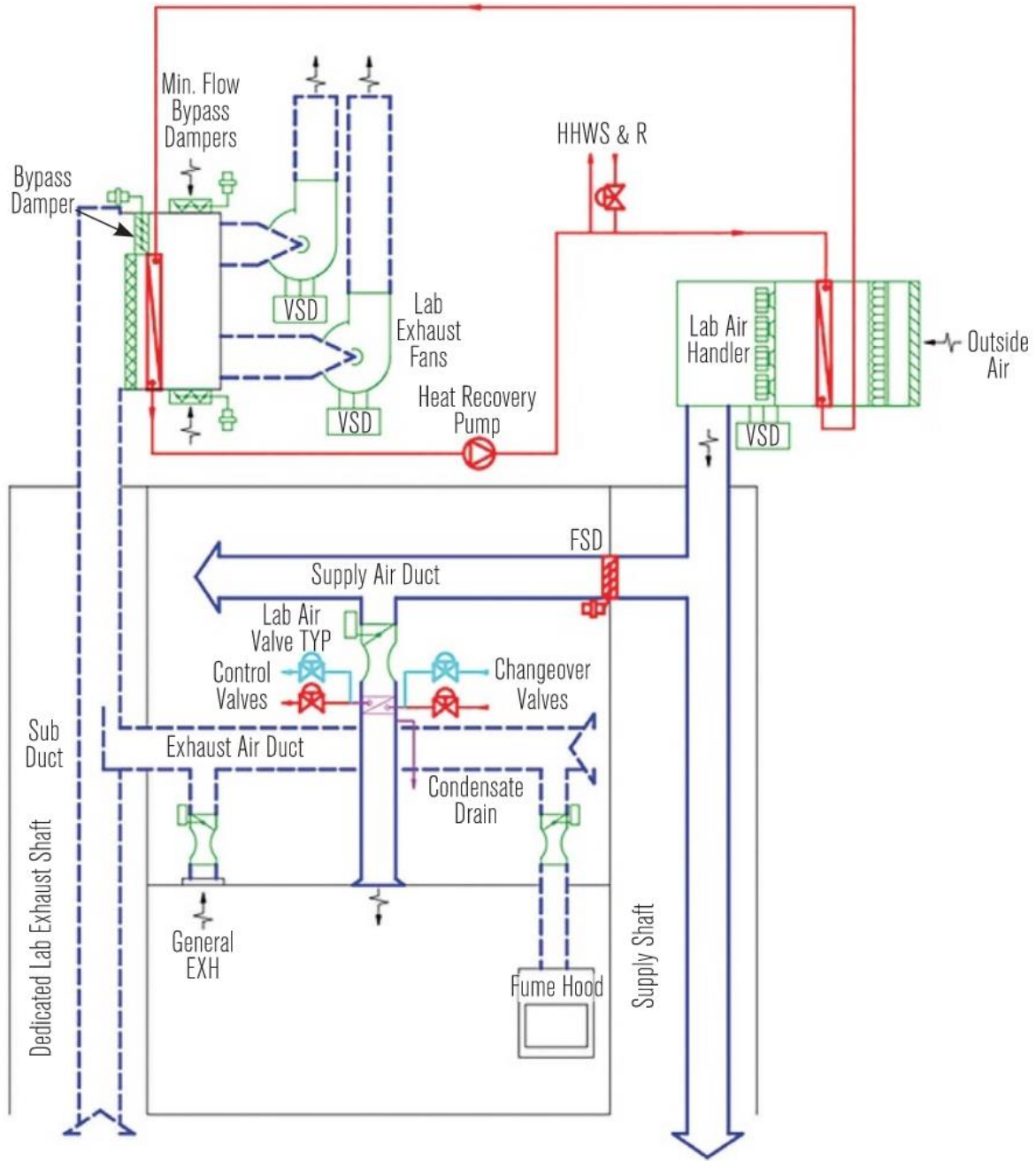

Figure 10: 4-Pipe VAV lab with heat recovery.

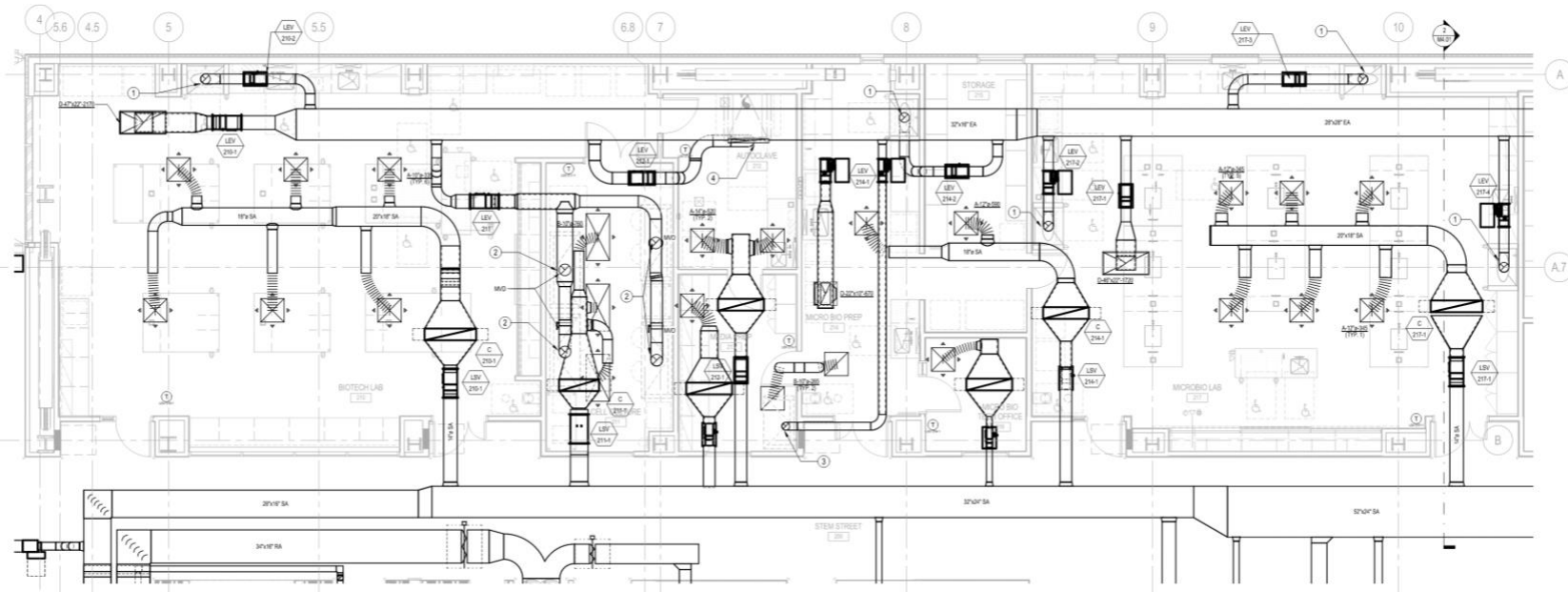

Figure 11: Typical 4-Pipe VAV lab ductwork plan.

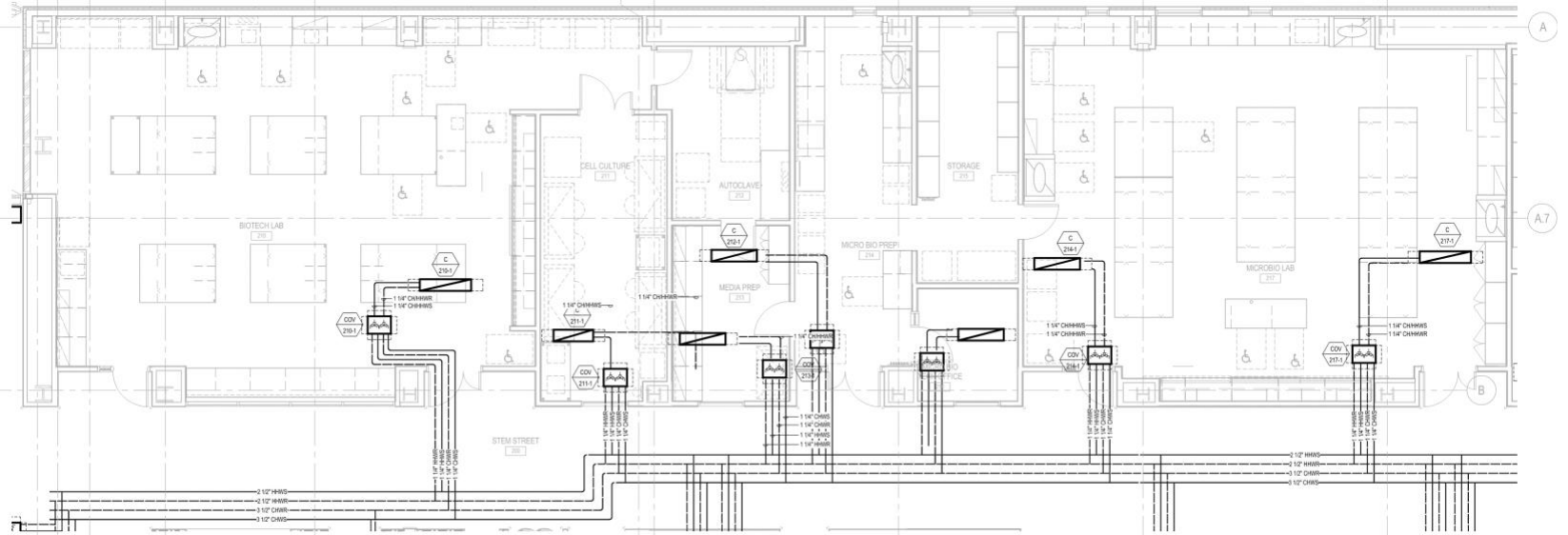
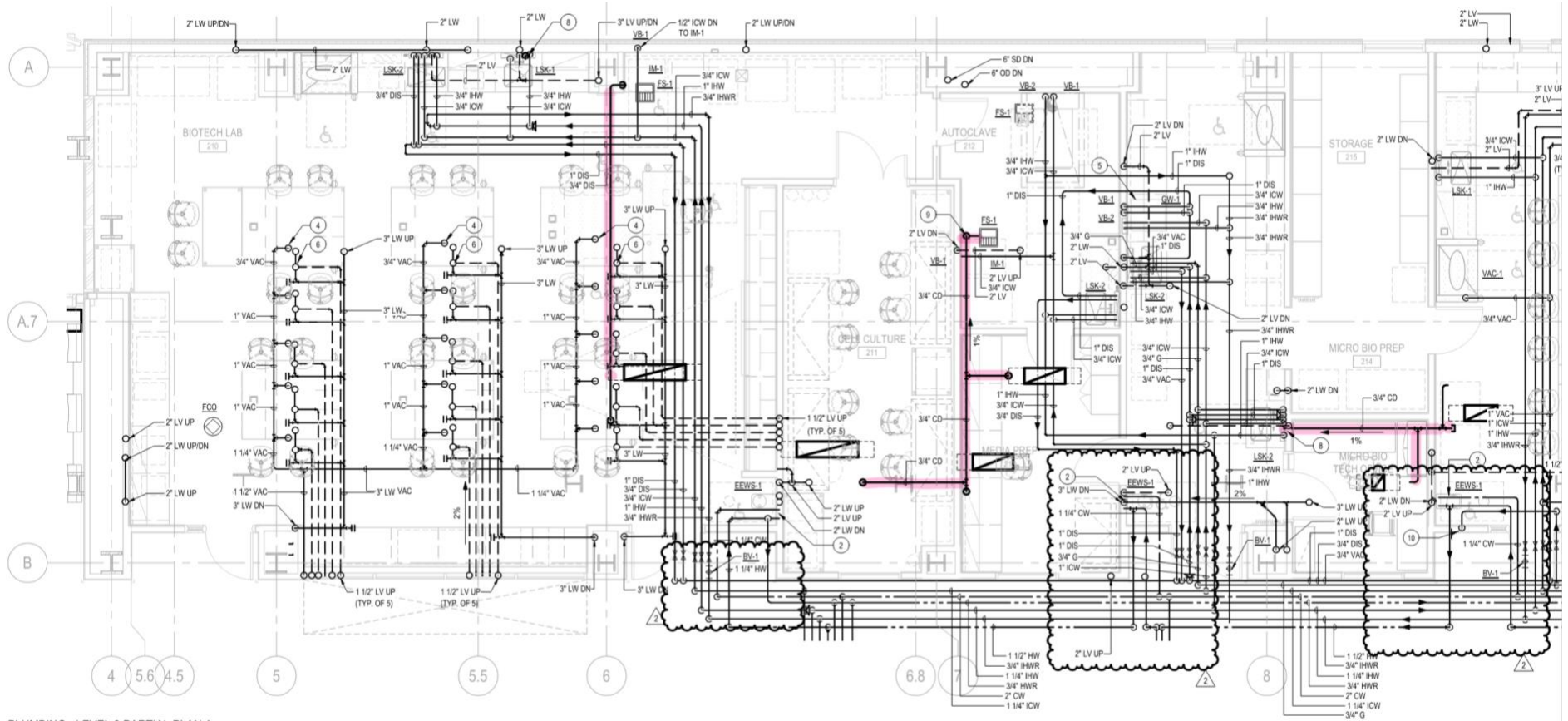

Figure 12: Typical 4-Pipe VAV lab hydronic plan.



1 PLUMBING - LEVEL 2 PARTIAL PLAN A
1/4" = 1'-0"

Figure 13: Typical 4-Pipe VAV lab plumbing plan (showing condensate gravity drained to nearby floor sinks and lab sinks).

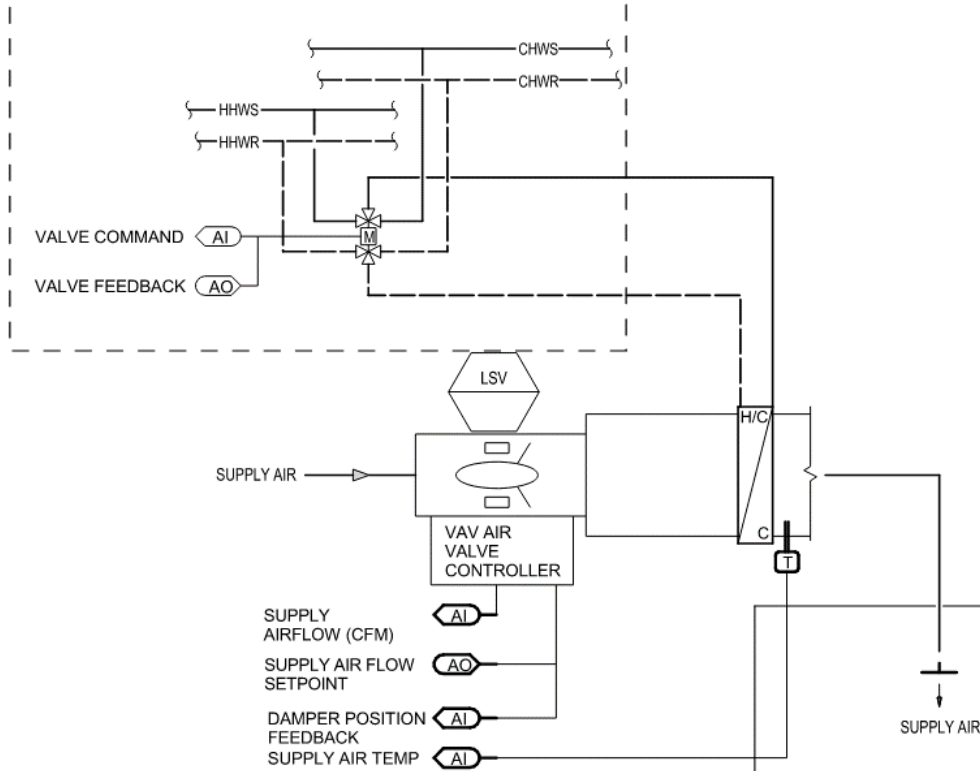

Figure 14: Typical 4-Pipe VAV control schematic.

5.1.3 Summary of Proposed Changes to Code Documents

The sections below summarize how the standards, Reference Appendices, Alternative Calculation Method (ACM) Reference Manuals, and compliance documents would be modified by the proposed change.³¹ See Section 7 of this report for detailed proposed revisions to code language.

5.1.3.1 Specific Purpose and Necessity of Proposed Code Changes

Each proposed change to language in Title 24, Part 1 and Part 6 as well as the reference appendices to Part 6 are described below. See Section 7.2 of this report for marked-up code language.

Section: 140.9(c)5 Reheat Limitation.

Specific Purpose: This is a new section covering the newly proposed requirement. See Section 7.2 for the proposed code language. See section 5.1.2 for justification and background information.

³¹ Visit EnergyCodeAce.com for trainings, tools and resources to help people understand existing code requirements.

5.1.3.2 Specific Purpose and Necessity of Changes to the Nonresidential ACM Reference Manual

No changes to the compliance software or ACM Reference Manual are proposed.

5.1.3.3 Summary of Changes to the Nonresidential Compliance Manual

No changes to the compliance manual are needed. Optionally examples of heat recovery (see section 3.1.2) and 4pipe VAV (see 5.1.2) could be included for design guidance.

5.1.3.4 Summary of Changes to Compliance Documents

No changes to the compliance documents are proposed.

5.1.4 Regulatory Context

5.1.4.1 Determination of Inconsistency or Incompatibility with Existing State Laws and Regulations

There are no relevant state or local laws or regulations.

5.1.4.2 Duplication or Conflicts with Federal Laws and Regulations

There are no relevant federal laws or regulations.

5.1.4.3 Difference From Existing Model Codes and Industry Standards

There are no relevant industry standards or model codes.

5.1.5 Compliance and Enforcement

When developing this proposal, the Statewide CASE Team considered methods to streamline the compliance and enforcement process and how negative impacts on market actors who are involved in the process could be mitigated or reduced. This section describes how to comply with the proposed code change. It also describes the compliance verification process. Appendix E presents how the proposed changes could impact various market actors.

The compliance verification activities related to this measure that need to occur during each phase of the project are described below:

- **Design Phase:** Lab designers will need to become familiar with the requirement and provide heating and cooling at each zone and not provide mechanical cooling at air handlers serving multiple zones. Many designers are familiar with 4-pipe VAV lab designs, but additional education and resources will be helpful.
- **Permit Application Phase:** The design phase changes affect the energy consultant and the permit application process. Energy consultants often inform the design team of these requirements and work with them on how best to

incorporate them into their design. Energy consultants also need training to understand the energy code changes. Documentation will need to be revised to properly demonstrate compliance.

- **Construction Phase:** Minor changes to this phase are expected from this measure. Most aspects of construction would look the same before and after this measure. For example, condensate piping for fan coils is common so mechanical contractors would not have an issue with condensate piping from 4-pipe VAV boxes.
- **Inspection Phase:** Changes to the inspection phase are expected to be minor. Inspectors would need to check that the necessary equipment has been installed as indicated by the prescriptive requirements included in this measure. Inspection will not be difficult. For example, an inspector can quickly and easily determine if a zone is 2-pipes or 4-pipes.

5.2 Market Analysis

5.2.1 Current Market Structure

The Statewide CASE Team performed a market analysis with the goals of identifying current technology availability, current product availability, and market trends. It then considered how the proposed standard may impact the market in general as well as individual market actors. Information was gathered about the incremental cost of complying with the proposed measure. Estimates of market size and measure applicability were identified through research and outreach with stakeholders including utility program staff, CEC staff, and a wide range of industry actors. In addition to conducting personalized outreach, the Statewide CASE Team discussed the current market structure and potential market barriers during a public stakeholder meeting that the Statewide CASE Team held on January 31, 2023.

The proposed measure requires the use of a system that can condition or heat air in individual zones, thus eliminating the need for reheat. This can be achieved through 4 pipe VAV systems, chilled beam systems or VRF, all of which are present and available today on the market and are currently in use in labs.

5.2.2 Technical Feasibility and Market Availability

Eliminating reheat by use of 4-pipe VAV, chilled beams, or VRF systems is common practice in labs. Additional solutions may come as a result of the requirement to eliminate reheat at the individual zones, but the market currently has a broad category of solutions that would meet this requirement.

5.2.2.1 Dehumidification

One consideration with a single zone coil used for both heating and cooling is that it is not possible to dehumidify the space by over-cooling with a cooling coil and then reheating with a downstream heating coil. Dehumidification is provided by the zone cooling coil in a 4-pipe VAV system (hence the need for condensate removal), but dehumidification will only occur if there is a space cooling load. This cannot be relied upon to maintain humidity if cooling load is not present.

Fortunately, dehumidification is not required in most lab spaces in California. Per Addendum k to ASHRAE Standard 62.1-2019, active dehumidification is not required for climates where outdoor dewpoint is below 68°F at the ASHRAE two percent annual dehumidification design conditions. Figure 15 shows that a small percentage of California climates have outdoor dewpoint at or above 68°F at the ASHRAE two percent annual dehumidification design conditions. The proposed requirement includes an exception for these locations.

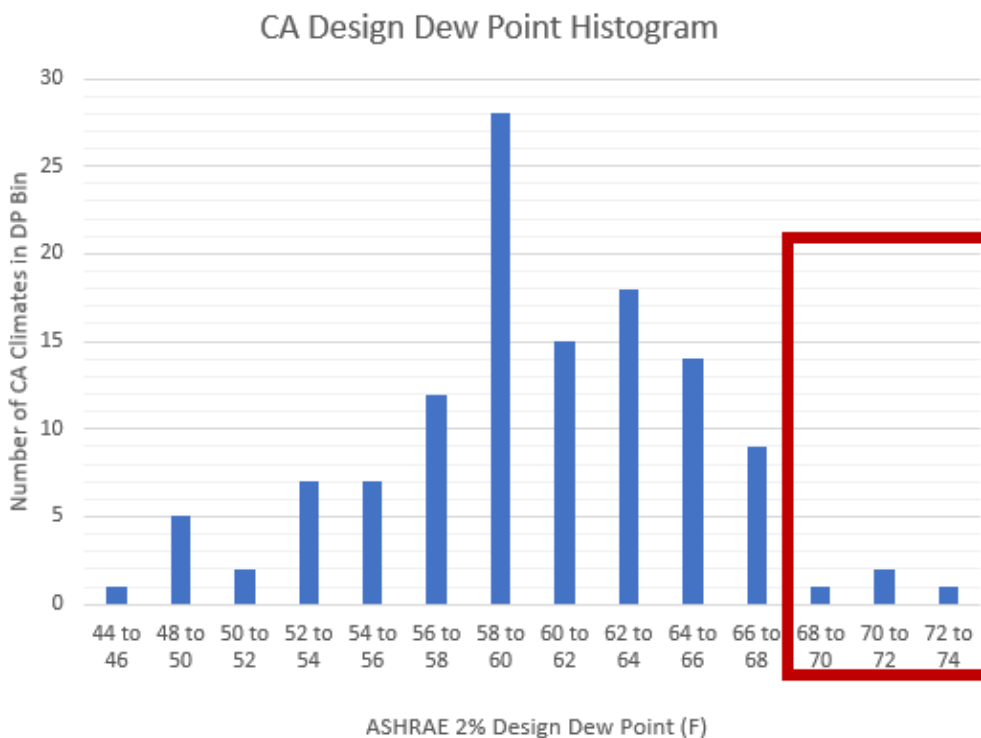

Figure 15: California design dew point histogram.

For the few lab spaces that require dehumidification for specific process requirements, active dehumidification can be provided by using separate cooling and heating coils at the zone level. This meets the proposed requirement. In fact, before 6-way control valves and changeover coils were common, it was common to minimize reheat in labs by installing separate cooling and heating coils at each lab zone. Figure 16 is an example of such a lab. A lab can also meet the proposed requirement with a

combination of changeover coils at most zones and dual coils at the few zones with strict humidity requirements.

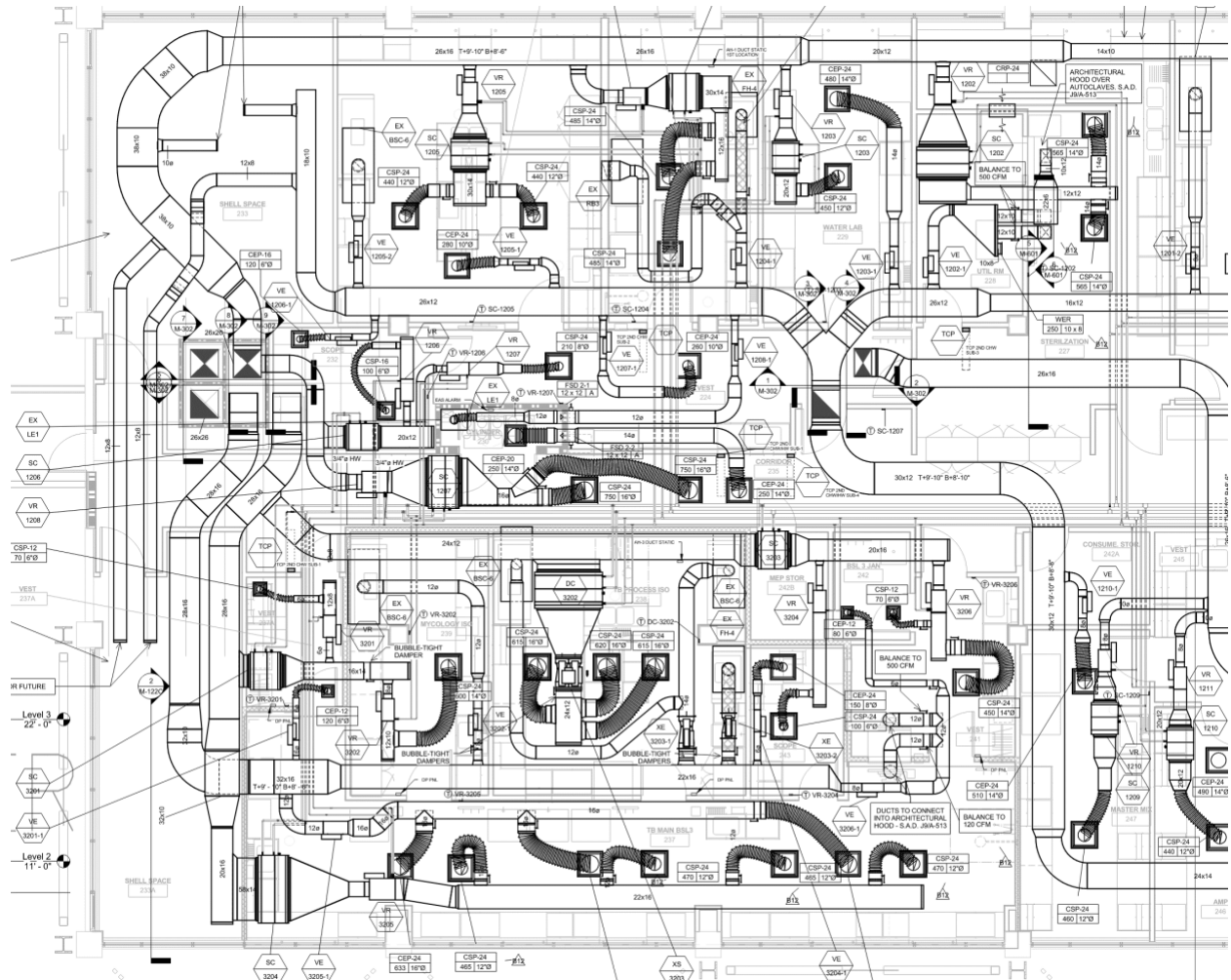
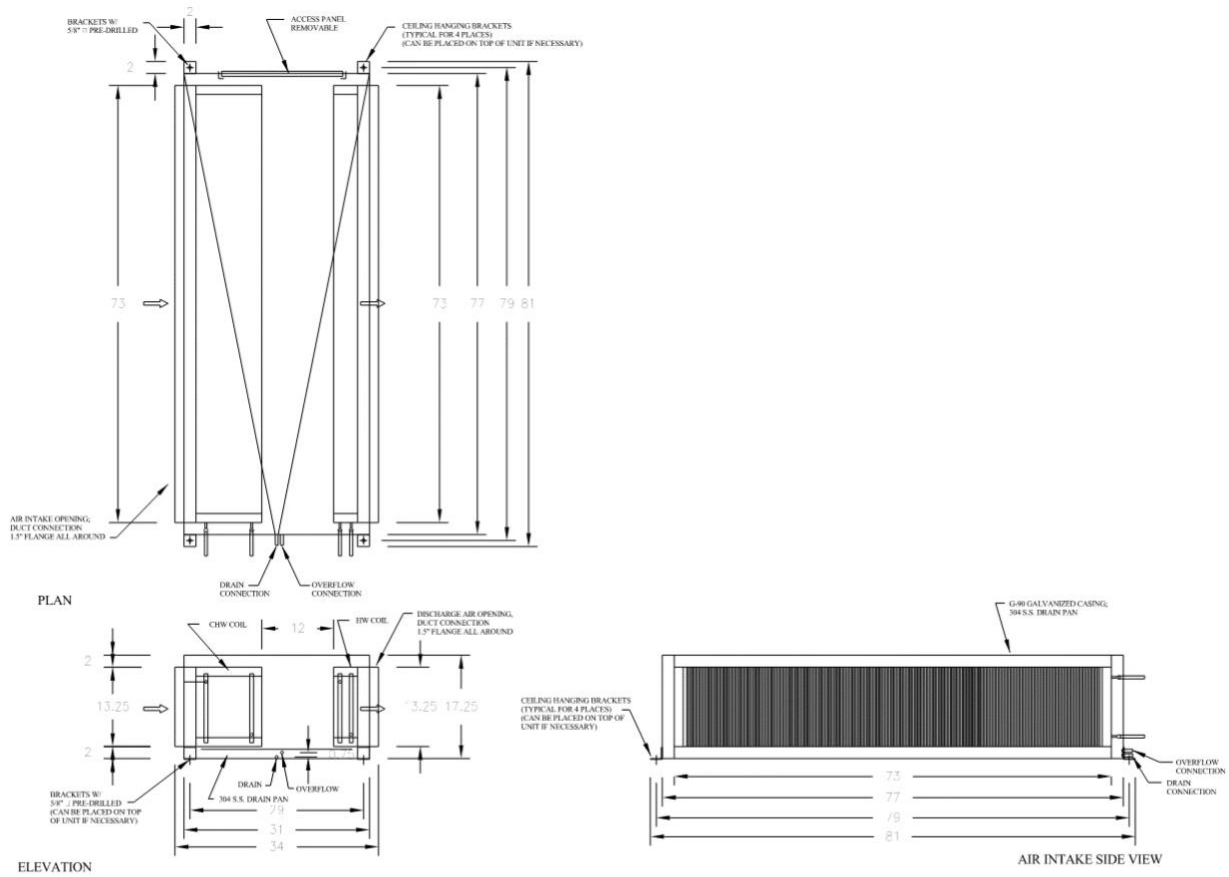

Figure 16: Typical lab with Chilled Water and Heating Water coils at the zones.

According to the mechanical contractor providing cost-estimating for this measure, two coils per zone is comparable in first cost to a single changeover coil, because the controls cost is lower for dual coils. They included the following control valves in their pricing for these options:

- Single coil with our standard changeover: (4) 2-way valves
- Single coil with 6-way changeover: (1) 6-way valve, (1) 2-way valve
- Dual coil: (2) 2-way valves



⑤ CHW / HW COIL - 2500 CFM
 3/4" = 1'-0"

Figure 17: Typical CHW + HW zone coil detail.

5.2.2.2 Condensate

Another consideration with zonal cooling is condensate removal. The condensate from the cooling coil must be piped to an acceptable drain such as a janitor's closet mop sink, lab sink, floor drain, etc. Condensate piping can either be gravity drained if the piping can be continuously sloped downward from the coil to the drain, or a condensate pump can be used if the piping cannot be continuously sloped. Many labs include lab sinks and most labs with zone cooling coils are able to use gravity drains (see Figure 10).

Where condensate pumps are required, it is possible to gravity drain groups of nearby zone coils to a single condensate pump, thus reducing the number of pumps and associated controls. Condensate pumps typically provide a high-water level alarm contact that is monitored by the DDC system to alert operators to a pump failure. Condensate pumps are reliable and easy to replace. To mitigate the risk of condensate pump failure redundant condensate pumps can be installed. In California, zone cooling coils rarely actually produce condensate. That is, coils run dry almost all the time. Zone

supply air temperature is typically reset between 55°F at peak load to 72°F at low load. If the outside air dewpoint is above the supply air temperature, then condensate is not produced. In San Francisco, for example, the dewpoint is above 55°F less than three percent of the year so at least 97 percent of the time, no condensate is produced.

The lifecycle cost analysis in Section 5.4 conservatively assumes that 50 percent of lab zones require condensate pumps and associated controls.

5.2.2.3 Space Constraints

Another consideration with zonal cooling is space constraints. If the zone coil is only for heating, then it can be sized above 500 fpm but if the coil is used for cooling, then it should not be sized above 500 fpm to prevent condensate carryover. The floor-to-floor heights on most new lab buildings provide sufficient space to accommodate changeover coils. The lab in Figure 8 has a 16-foot floor-to-floor height and is easily able to accommodate changeover coils and gravity drained condensate. The lab in Figure 12 and Figure 14 is a retrofit of an office building with a 12-foot floor-to-floor height. This design was able to accommodate dual zone coils, which take up more space than changeover coils. This lab used condensate pumps, rather than gravity drains.

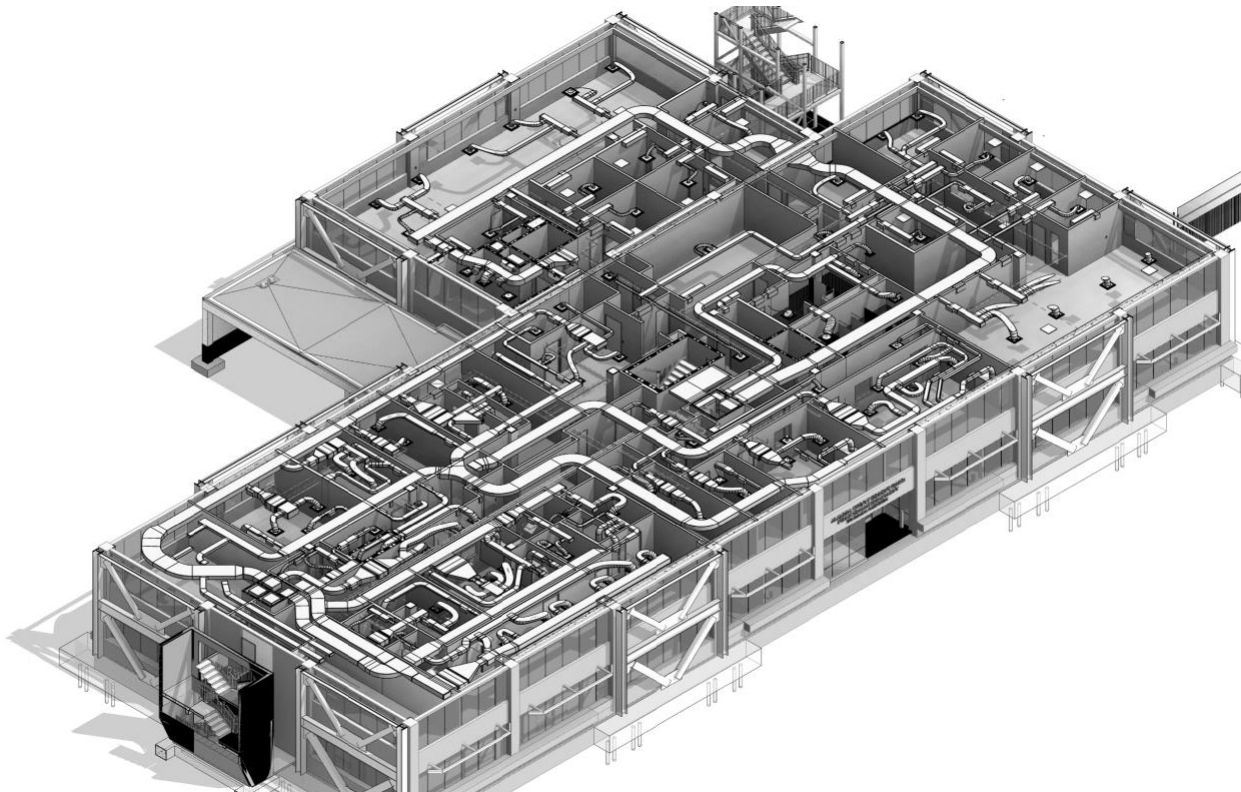

Figure 18: Isometric view of typical lab with CHW + HW zone coils.

5.2.3 Market Impacts and Economic Assessments

5.2.3.1 Impact on Builders

Builders of residential and commercial structures are directly impacted by many of the measures proposed by the Statewide CASE Team for the 2025 code cycle. It is within the normal practices of these businesses to adjust their building practices to changes in building codes. When necessary, builders engage in continuing education and training to remain compliant with changes to design practices and building codes.

California’s construction industry comprises approximately 93,000 business establishments and 943,000 employees (see Table 49Table 2). For 2022, total estimated payroll will be about \$78 billion. Nearly 72,000 of these business establishments and 473,000 employees are engaged in the residential building sector, while another 17,600 establishments and 369,000 employees focus on the commercial sector. The remainder of establishments and employees work in industrial, utilities, infrastructure, and other heavy construction roles (the industrial sector).

Table 49: California Construction Industry, Establishments, Employment, and Payroll in 2022 (Estimated)

Building Type	Construction Sectors	Establishments	Employment	Annual Payroll (Billions \$)
Residential	All	71,889	472,974	31.2
Residential	Building Construction Contractors	27,948	130,580	9.8
Residential	Foundation, Structure, & Building Exterior	7,891	83,575	5.0
Residential	Building Equipment Contractors	18,108	125,559	8.5
Residential	Building Finishing Contractors	17,942	133,260	8.0
Commercial	All	17,621	368,810	35.0
Commercial	Building Construction Contractors	4,919	83,028	9.0
Commercial	Foundation, Structure, & Building Exterior	2,194	59,110	5.0
Commercial	Building Equipment Contractors	6,039	139,442	13.5
Commercial	Building Finishing Contractors	4,469	87,230	7.4
Industrial, Utilities, Infrastructure, & Other (Industrial+)	All	4,206	101,002	11.4
Industrial+	Building Construction	288	3,995	0.4
Industrial+	Utility System Construction	1,761	50,126	5.5
Industrial+	Land Subdivision	907	6,550	1.0
Industrial+	Highway, Street, and Bridge Construction	799	28,726	3.1
Industrial+	Other Heavy Construction	451	11,605	1.4

Source: (State of California n.d.)

The proposed change to reheat limitation would likely affect commercial builders but would not impact firms that focus on construction and retrofit of industrial buildings, utility systems, public infrastructure, or other heavy construction. The effects on the residential and commercial building industry would not be felt by all firms and workers, but rather would be concentrated in specific industry subsectors. Table 3 shows the commercial building subsectors the Statewide CASE Team expects to be impacted by the changes proposed in this report. The Statewide CASE Team’s estimates of the magnitude of these impacts are shown in Section 2.2.4 Economic Impacts.

Table 50: Specific Subsectors of the California Commercial Building Industry Impacted by Proposed Change to Code/Standard by Subsector in 2022 (Estimated)

Construction Subsector	Establishments	Employment	Annual Payroll (Billions \$)
Nonresidential plumbing & HVAC contractors	2,346	55,572	5.5

Source: (State of California n.d.)

5.2.3.2 Impact on Building Designers and Energy Consultants

Adjusting design practices to comply with changing building codes is within the normal practices of building designers. Building codes (including Title 24, Part 6) are typically updated on a three-year revision cycle, and building designers and energy consultants engage in continuing education and training to remain compliant with changes to design practices and building codes.

Businesses that focus on residential, commercial, institutional, and industrial building design are contained within the Architectural Services sector (North American Industry Classification System 541310). Table 4 shows the number of establishments, employment, and total annual payroll for Building Architectural Services. The proposed code changes would potentially impact all firms within the Architectural Services sector. The Statewide CASE Team anticipates the impacts of reheat limitation to affect firms that focus on labs construction.

There is not a North American Industry Classification System (NAICS)³² code specific to energy consultants. Instead, businesses that focus on consulting related to building energy efficiency are contained in the Building Inspection Services sector (NAICS

³² NAICS is the standard used by federal statistical agencies in classifying business establishments for the purpose of collecting, analyzing, and publishing statistical data related to the U.S. business economy. NAICS was developed jointly by the U.S. Economic Classification Policy Committee (ECPC), Statistics Canada, and Mexico's Instituto Nacional de Estadística y Geografía, to allow for a high level of comparability in business statistics among the North American countries. NAICS replaced the Standard Industrial Classification (SIC) system in 1997.

541350), which is comprised of firms primarily engaged in the physical inspection of residential and nonresidential buildings.³³ It is not possible to determine which business establishments within the Building Inspection Services sector are focused on energy efficiency consulting. The information shown in Table 4 provides an upper bound indication of the size of this sector in California.

Table 51: California Building Designer and Energy Consultant Sectors in 2022 (Estimated)

Sector	Establishments	Employment	Annual Payroll (Millions \$)
Architectural Services^a	4,134	31,478	3,623.3
Building Inspection Services^b	1,035	3,567	280.7

Source: (State of California n.d.)

- a. Architectural Services (NAICS 541310) comprises private-sector establishments primarily engaged in planning and designing residential, institutional, leisure, commercial, and industrial buildings and structures.
- b. Building Inspection Services (NAICS 541350) comprises private-sector establishments primarily engaged in providing building (residential & nonresidential) inspection services encompassing all aspects of the building structure and component systems, including energy efficiency inspection services.

5.2.3.3 Impact on Occupational Safety and Health

The proposed code change does not alter any existing federal, state, or local regulations pertaining to safety and health, including rules enforced by the California Division of Occupational Safety and Health (DOSH). All existing health and safety rules would remain in place. Complying with the proposed code change is not anticipated to have adverse impacts on the safety or health of occupants or those involved with the construction, commissioning, and maintenance of the building.

5.2.3.4 Impact on Building Owners and Occupants

Commercial Buildings

The commercial building sector includes a wide array of building types, including offices, restaurants and lodging, retail, and mixed-use establishments, and warehouses (including refrigerated) (Kenney 2019). Energy use by occupants of commercial buildings also varies considerably, with electricity used primarily for lighting, space cooling and conditioning, and refrigeration, while natural gas is used primarily for water

³³ Establishments in this sector include businesses primarily engaged in evaluating a building's structure and component systems and includes energy efficiency inspection services and home inspection services. This sector does not include establishments primarily engaged in providing inspections for pests, hazardous wastes or other environmental contaminants, nor does it include state and local government entities that focus on building or energy code compliance/enforcement of building codes and regulations.

heating and space heating. According to information published in the 2019 California Energy Efficiency Action Plan, there is more than 7.5 billion square feet of commercial floor space in California consuming 19 percent of California’s total annual energy use (Kenney 2019). The diversity of building and business types within this sector creates a challenge for disseminating information on energy and water efficiency solutions, as does the variability in sophistication of building owners and the relationships between building owners and occupants.

Estimating Impacts

Building owners and occupants would benefit from lower energy bills. As discussed in Section 2.2.4.1, when building occupants save on energy bills, they tend to spend it elsewhere in the economy thereby creating jobs and economic growth for the California economy. The Statewide CASE Team does not expect the proposed code change for the 2025 code cycle to impact building owners or occupants adversely.

5.2.3.5 Impact on Building Component Retailers (Including Manufacturers and Distributors)

The Statewide CASE Team anticipates the proposed change would have no material impact on California component retailers.

5.2.3.6 Impact on Building Inspectors

Table 5 shows employment and payroll information for state and local government agencies in which many inspectors of residential and commercial buildings are employed. Building inspectors participate in continuing education and training to stay current on all aspects of building regulations, including energy efficiency. The Statewide CASE Team, therefore, anticipates the proposed change would have no impact on employment of building inspectors or the scope of their role conducting energy efficiency inspections.

Table 52: Employment in California State and Government Agencies with Building Inspectors in 2022 (Estimated)

Sector	Govt.	Establishments	Employment	Annual Payroll (Million \$)
Administration of Housing Programs ^a	State	18	265	29.0
	Local	38	3,060	248.6
Urban and Rural Development Admin ^b	State	38	764	71.3
	Local	52	2,481	211.5

Source: (State of California, Employment Development Department n.d.)

- a. Administration of Housing Programs (NAICS 925110) comprises government establishments primarily engaged in the administration and planning of housing programs, including building codes and standards, housing authorities, and housing programs, planning, and development.

- b. Urban and Rural Development Administration (NAICS 925120) comprises government establishments primarily engaged in the administration and planning of the development of urban and rural areas. Included in this industry are government zoning boards and commissions.

5.2.3.7 Impact on Statewide Employment

As described in Sections 2.2.3.1 through 2.2.3.6, the Statewide CASE Team does not anticipate significant employment or financial impacts to any particular sector of the California economy. This is not to say that the proposed change would not have modest impacts on employment in California. In Section 2.2.4, the Statewide CASE Team estimated the proposed change in reheat limitation would affect statewide employment and economic output directly and indirectly through its impact on builders, designers and energy consultants, and building inspectors. In addition, the Statewide CASE Team estimated how energy savings associated with the proposed change in reheat limitation would lead to modest ongoing financial savings for California residents, which would then be available for other economic activities.

5.2.4 Economic Impacts

For the 2025 code cycle, the Statewide CASE Team used the IMPLAN model software,³⁴ along with economic information from published sources, and professional judgement to develop estimates of the economic impacts associated with each of the proposed code changes. Conceptually, IMPLAN estimates jobs created as a function of incoming cash flow in different sectors of the economy, due to implementing a code or a standard. The jobs created are typically categorized into direct, indirect, and induced employment. For example, cash flow into a manufacturing plant captures direct employment (jobs created in the manufacturing plant), indirect employment (jobs created in the sectors that provide raw materials to the manufacturing plant) and induced employment (jobs created in the larger economy due to purchasing habits of people newly employed in the manufacturing plant). Eventually, IMPLAN computes the total number of jobs created due to a code. The assumptions of IMPLAN include constant returns to scale, fixed input structure, industry homogeneity, no supply constraints, fixed technology, and constant byproduct coefficients. The model is also static in nature and is a simplification of how jobs are created in the macro-economy.

The economic impacts developed for this report are only estimates and are based on limited and to some extent speculative information. The IMPLAN model provides a relatively simple representation of the California economy and, though the Statewide CASE Team is confident that the direction and approximate magnitude of the estimated economic impacts are reasonable, it is important to understand that the IMPLAN model is a simplification of extremely complex actions and interactions of individual,

³⁴ IMPLAN employs economic data and advanced economic impact modeling to estimate economic impacts for interventions like changes to the California Title 24, Part 6 code. For more information on the IMPLAN modeling process, see www.IMPLAN.com.

businesses, and other organizations as they respond to changes in energy efficiency codes. In all aspects of this economic analysis, the CASE Authors rely on conservative assumptions regarding the likely economic benefits associated with the proposed code change. By following this approach, the economic impacts presented below represent lower bound estimates of the actual benefits associated with this proposed code change.

Adoption of this code change proposal would result in relatively modest economic impacts through the additional direct spending by in the commercial building industry, architects, energy consultants, and building inspectors. The Statewide CASE Team does not anticipate that money saved by commercial building owners or other organizations affected by the proposed 2025 code cycle regulations would result in additional spending by those businesses.

Table 53: Estimated Impact that Adoption of the Proposed Measure would have on the California Commercial Construction Sector

Impact Type	Employment	Labor Income	Value Added	Output (Million)
Direct Effect	7.6	\$592,953	\$685,267	\$1,167,152
Indirect Effect	1.9	\$161,524	\$253,461	\$466,765
Induced Effect	3.2	\$216,646	\$387,886	\$617,369
Total Effect	12.7	\$971,122	\$1,326,614	\$2,251,286

Source: Statewide CASE Team analysis of data from the IMPLAN modeling software.³⁵

Table 54: Estimated Impact that Adoption of the Proposed Measure would have on the California Building Designers and Energy Consultants Sectors

Impact Type	Employment	Labor Income	Value Added	Output
Direct Effect	0.0	\$4,751	\$4,703	\$7,434
Indirect Effect	0.0	\$1,415	\$1,966	\$3,165
Induced Effect	0.0	\$1,773	\$3,175	\$5,053
Total Effect	0.1	\$7,938	\$9,844	\$15,652

Source: Statewide CASE Team analysis of data from the IMPLAN modeling software.

Table 55: Estimated Impact that Adoption of the Proposed Measure would have on California Building Inspectors

Impact Type	Employment	Labor Income	Value Added	Output
Direct Effect	0.0	\$242	\$288	\$349
Indirect Effect	0.0	\$22	\$35	\$61
Induced Effect	0.0	\$76	\$137	\$217
Total Effect	0.0	\$341	\$459	\$628

Source: Statewide CASE Team analysis of data from the IMPLAN modeling software.

³⁵ IMPLAN® model, 2020 Data, IMPLAN Group LLC, IMPLAN System (data and software), 16905 Northcross Dr., Suite 120, Huntersville, NC 28078 www.IMPLAN.com

5.2.4.1 Creation or Elimination of Jobs

The Statewide CASE Team does not anticipate that the measures proposed for the 2025 code cycle regulation would lead to the creation of new *types* of jobs or the elimination of *existing* types of jobs. In other words, the Statewide CASE Team’s proposed change would not result in economic disruption to any sector of the California economy. Rather, the estimates of economic impacts discussed in Section 5.2.4 would lead to modest changes in employment of existing jobs.

5.2.4.2 Creation or Elimination of Businesses in California

As stated in Section 5.2.4.1, the Statewide CASE Team’s proposed change would not result in economic disruption to any sector of the California economy. The proposed change represents a modest change to eliminate reheat for lab HVAC systems, which would not excessively burden or competitively disadvantage California businesses – nor would it necessarily lead to a competitive advantage for California businesses. Therefore, the Statewide CASE Team does not foresee any new businesses being created, nor does the Statewide CASE Team think any existing businesses would be eliminated due to the proposed code changes.

5.2.4.3 Competitive Advantages or Disadvantages for Businesses in California

The proposed code changes would apply to all businesses incorporated in California, regardless of whether the business is located inside or outside of the state.³⁶ Therefore, the Statewide CASE Team does not anticipate that these measures proposed for the 2025 code cycle regulation would have an adverse effect on the competitiveness of California businesses. Likewise, the Statewide CASE Team does not anticipate businesses located outside of California would be advantaged or disadvantaged.

5.2.4.4 Increase or Decrease of Investments in the State of California

The Statewide CASE Team analyzed national data on corporate profits and capital investment by businesses that expand a firm’s capital stock (referred to as net private domestic investment, or NPDI).³⁷ As Table 56 shows, between 2017 and 2021, NPDI as a percentage of corporate profits ranged from a low of 18 in 2020 due to the worldwide economic slowdowns associated with the COVID 19 pandemic to a high of 35 percent in 2019, with an average of 26 percent. While only an approximation of the proportion of business income used for net capital investment, the Statewide CASE Team believes it

³⁶ Gov. Code, §§ 11346.3(c)(1)(C), 11346.3(a)(2); 1 CCR § 2003(a)(3) Competitive advantages or disadvantages for California businesses currently doing business in the state.

³⁷ Net private domestic investment is the total amount of investment in capital by the business sector that is used to expand the capital stock, rather than maintain or replace due to depreciation. Corporate profit is the money left after a corporation pays its expenses.

provides a reasonable estimate of the proportion of proprietor income that would be reinvested by business owners into expanding their capital stock.

Table 56: Net Domestic Private Investment and Corporate Profits, U.S.

Year	Net Domestic Private Investment by Businesses, Billions of Dollars	Corporate Profits After Taxes, Billions of Dollars	Ratio of Net Private Investment to Corporate Profits (Percent)
2017	518.473	1882.460	28
2018	636.846	1977.478	32
2019	690.865	1952.432	35
2020	343.620	1908.433	18
2021	506.331	2619.977	19
5-Year Average	<i>Fill / "Intentionally blank"</i>	<i>Fill / "Intentionally blank"</i>	26

Source: (Federal Reserve Economic Data (FRED) n.d.)

The Statewide CASE Team does not anticipate that the economic impacts associated with the proposed measure would lead to significant change (increase or decrease) in investment, directly or indirectly, in any affected sectors of California’s economy. Nevertheless, the Statewide CASE Team is able to derive a reasonable estimate of the change in investment by California businesses based on the estimated change in economic activity associated with the proposed measure and its expected effect on proprietor income, which the Statewide CASE Team uses a conservative estimate of corporate profits, a portion of which the Statewide CASE Team assumes will be allocated to net business investment.³⁸

5.2.4.5 Incentives for Innovation in Products, Materials, or Processes

By eliminating reheat, the market will look for ways to heat or condition air in the individual zones more economically or find new and novel ways to economize space requirements for the HVAC systems.

5.2.4.6 Effects on the State General Fund, State Special Funds, and Local Governments

The Statewide CASE Team does not expect the proposed code changes would have a measurable impact on California’s General Fund, any state special funds, or local government funds.

³⁸ 26 percent of proprietor income was assumed to be allocated to net business investment; see Table 9.

Cost of Enforcement

Cost to the State: State government already has budget for code development, education, and compliance enforcement. While state government will be allocating resources to update the Title 24, Part 6 Standards, including updating education and compliance materials and responding to questions about the revised requirements, these activities are already covered by existing state budgets. The costs to state government are small when compared to the overall costs savings and policy benefits associated with the code change proposals. Eliminating reheat would drive energy savings and GHG reduction by eliminating excessive air processing, and this has been shown to be cost effective even in mild climates zones in California.

Cost to Local Governments: All proposed code changes to Title 24, Part 6 would result in changes to compliance determinations. Local governments would need to train building department staff on the revised Title 24, Part 6 Standards. While this re-training is an expense to local governments, it is not a new cost associated with the 2025 code change cycle. The building code is updated on a triennial basis, and local governments plan and budget for retraining every time the code is updated. There are numerous resources available to local governments to support compliance training that can help mitigate the cost of retraining, including tools, training and resources provided by the IOU Codes and Standards program (such as Energy Code Ace). As noted in Section 2.1.5 and Appendix E, the Statewide CASE Team considered how the proposed code change might impact various market actors involved in the compliance and enforcement process and aimed to minimize negative impacts on local governments.

5.2.4.7 Impacts on Specific Persons

While the objective of any of the Statewide CASE Team's proposal is to promote energy efficiency, the Statewide CASE Team recognizes that there is the potential that a proposed code change may result in unintended consequences. The proposed changes are expected to drive energy savings for labs, and not expected to unduly or negatively impact any persons outside of labs. Refer to Section **Error! Reference source not found.** for more details addressing energy equity and environmental justice.

5.2.5 Fiscal Impacts

5.2.5.1 Mandates on Local Agencies or School Districts

This measure would impact any schools or local agencies that have labs slated for new construction.

5.2.5.2 Costs to Local Agencies or School Districts

This measure may have greater first costs than a system with reheat, but the measure has been shown to be cost effective and thus there are no significant additional costs expected to local agencies or school districts.

5.2.5.3 Costs or Savings to Any State Agency

This measure may have greater first costs than a system with reheat, but the measure has been shown to be cost effective and thus there are no significant additional costs expected to any state agency.

5.2.5.4 Other Non-Discretionary Cost or Savings Imposed on Local Agencies

There are no added non-discretionary costs or savings to local agencies as this would not impact non-discretionary funds.

5.2.5.5 Costs or Savings in Federal Funding to the State

There are no costs or savings to federal funding to the state as this measure does not infringe or otherwise touch upon any federal funds associated with this measure.

5.3 Energy Savings

5.3.1 Energy Savings Methodology

5.3.1.1 Key Assumptions for Energy Savings Analysis

The analysis assessed the potential energy savings of implementing a reheat limitation measure in a lab building using the 2025 lab prototype provided by the CEC. The prototype was adjusted to reflect a one-story building with five lab thermal zones: four perimeter zones, and one core zone. EnergyPlus was used to conduct energy simulation by climate zone.

The analysis found that a reheat limitation measure could result in significant energy savings by reducing the need for reheat at the zone level. The baseline case, or Standard Design, used a central multizone system; packaged variable air volume (PVAV) with DX cooling, hot water heating, and hot water reheat at terminal units (all hot water supplied a gas boiler). For the proposed case, or Proposed Design, the HVAC system configuration was changed to a single zone VAV for each thermal zone. This change meant that in the base case, all thermal zones were served by a main air handler and each zone had terminal units for reheat, while in the proposed case, each thermal zone had its own HVAC unit.

This change limited the need for reheating at the zone level, which generated cooling and heating savings. For this draft report, the analysis was conducted for Climate Zones

2, 7, and 12. The Statewide CASE Team will expand the analysis to include all 16 climate zones in the final draft.

5.3.1.2 Energy Savings Methodology per Prototypical Building

The Statewide CASE Team measured per-unit energy savings expected from the proposed code changes in several ways to quantify key impacts. First, savings are calculated by fuel type. Electricity savings are measured in terms of both energy usage and peak demand reduction. Natural gas savings are quantified in terms of energy usage. Second, the Statewide CASE Team calculated source energy savings. Source energy represents the total amount of raw fuel required to operate a building. In addition to all energy used from on-site production, source energy incorporates all transmission, delivery, and production losses. The hourly source energy values provided by CEC are proportional to GHG emissions. Finally, the Statewide CASE Team calculated Long-term Systemwide Cost (LSC) savings, formerly known as Time Dependent Value (TDV) energy cost savings. LSC savings are calculated using hourly energy cost metrics for both electricity and natural gas provided by the CEC. These LSC hourly factors are projected over the 30-year life of the building. The LSC hourly factors incorporates the hourly cost of marginal generation, transmission and distribution, fuel, capacity, losses, and cap-and-trade-based CO2 emissions (California Energy Commission 2022).

The CEC directed the Statewide CASE Team to model the energy impacts using specific prototypical building models that represent typical building geometries for different types of buildings. They also estimate the amount of total existing building stock in 2026, which the Statewide CASE Team used to approximate savings from building alteration (California Energy Commission 2022, California Energy Commission 2022). The prototype buildings that the Statewide CASE Team used in the analysis are presented in Table 57.

Table 57: Prototype Buildings Used for Energy, Demand, Cost, and Environmental Impacts Analysis

Prototype Name	Number of Stories	Floor Area (Square Feet)	Description
Lab Only Single Story	1	17,876	One story office building with 5 zones and a ceiling plenum on each floor. WWR-0.33

The Statewide CASE Team estimated LSC energy, source energy, electricity, natural gas, peak demand, and GHG impacts by simulating the proposed code change in EnergyPlus using prototypical buildings and rulesets from the 2025 Research Version of the California Building Energy Code Compliance (CBECC) software (California Energy Commission n.d.).

CBECC generates two models based on user inputs: the Standard Design and the Proposed Design. The Standard Design represents the geometry of the prototypical building and a design that uses a set of features that result in a Lifecycle energy budget and Source energy budget that is minimally compliant with 2022 Title 24, Part 6 code requirements. Features used in the Standard Design are described in the 2022 Nonresidential ACM Reference Manual. The Proposed Design represents the same geometry as the Standard Design, but it assumes the energy features that the software user describes with user inputs. To develop savings estimates for the proposed code changes, the Statewide CASE Team created a Standard Design and Proposed Design for each prototypical building with the Standard Design representing compliance with 2022 code and the Proposed Design representing compliance with the proposed requirements. Comparing the energy impacts of the Standard Design to the Proposed Design reveals the impacts of the proposed code change relative to a building that follows industry typical practices.

The Proposed Design was identical to the Standard Design in all ways except for the revisions that represent the proposed changes to the code. Table 58 presents precisely which parameters were modified and what values were used in the Standard Design and Proposed Design.

Table 58: Modifications Made to Standard Design in Each Prototype to Simulate Proposed Code Change

Prototype ID	Climate Zone	Objects Modified	Parameter Name	Standard Design Parameter Value	Proposed Design Parameter Value
Lab Only Single Story	12	Air System	HVAC System Type	PVAV serving all thermal zone with reheat at terminal units	SZVAV for each thermal zone

CBECC calculates whole-building energy consumption for every hour of the year measured in kilowatt-hours per year (kWh/yr) and therms per year (therms/yr). It then applies the 2025 LSC hourly factors to calculate lifecycle energy use in kilo British thermal units per year (kBtu/yr), source energy factors to calculate source energy use in kilo British thermal units per year (kBtu/yr), and hourly GHG emissions factors to calculate annual GHG emissions (metric tons of carbon dioxide emissions equivalent). CBECC also generates LSC savings values measured in 2026 present value dollars (2026 PV\$) and nominal dollars. CBECC also calculates annual peak electricity demand measured in kilowatts (kW).

The energy impacts of the proposed code change do vary by climate zone. The Statewide CASE Team simulated the energy impacts in Climate Zones 2, 7, and 12, and applied the climate-zone specific LSC hourly factors when calculating energy and energy cost impacts.

Per-unit energy impacts for nonresidential buildings are presented in savings per square foot. Annual energy, GHG, and peak demand impacts for each prototype building were translated into impacts per square foot by dividing by the floor area of the prototype building. This step allows for an easier comparison of savings across different building types and enables a calculation of statewide savings using the construction forecast that is published in terms of floor area by building type.

5.3.1.3 Statewide Energy Savings Methodology

The per-unit energy impacts were extrapolated to statewide impacts using the statewide construction forecasts that the CEC provided. The statewide construction forecasts estimate new construction/additions that would occur in 2026, the first year that the 2025 Title 24, Part 6 requirements are in effect (California Energy Commission 2022). They also estimate the amount of total existing building stock in 2026, which the Statewide CASE Team used to approximate savings from building alterations. The construction forecast provides construction (new construction/additions and existing building stock) by building type and climate zone. Appendix A presents additional information about the methodology and assumptions used to calculate statewide energy impacts.

5.3.2 Per-Unit Energy Impacts Results

Energy savings and peak demand reductions per unit are presented in Table 59. The presented savings are for new construction. The per-unit energy savings figures do not account for naturally occurring market adoption or compliance rates.

Table 59: First-Year Electricity Savings (kWh) Per Square Foot – Reheat Limitation 4-Pipe VAV

Climate Zone	2	3	7	12
First-Year Electricity Savings (kWh)	1.34	2.29	4.73	1.92
First-Year Peak Demand Reduction (kW)	0.06	0.18	0.45	0.18
First-Year Natural Gas Savings (kBtu)	19.14	30.39	68.87	37.61
First-Year Source Energy Savings (kBtu)	18.56	29.97	69.01	36.45
LSC Savings (2026 PV\$)	15.66	26.35	59.83	28.35

5.4 Cost and Cost Effectiveness

5.4.1 Energy Cost Savings Methodology

Energy cost savings were calculated by applying the LSC hourly factors to the energy savings estimates that were derived using the methodology described in Section 5.3.1. LSC hourly factors are a normalized metric to calculate energy cost savings that account for the variable cost of electricity and natural gas for each hour of the year,

along with how costs are expected to change over the period of analysis. In this case, the period of analysis used is 30 years.

The CEC requested energy cost savings over the 30-year period of analysis in both 2026 present value dollars (2026 PV\$) and nominal dollars. The cost-effectiveness analysis uses energy cost values in 2026 PV\$. Costs and cost effectiveness using and 2026 PV\$ are presented in Section 5.4 of this report. CEC uses results in nominal dollars to complete the Economic and Fiscal Impacts Statement (From 399) for the entire package of proposed change to Title 24, Part 6. Appendix G presents energy cost savings results in nominal dollars.

5.4.2 Energy Cost Savings Results

Per-unit energy cost savings for newly constructed buildings that are realized over the 30-year period of analysis are presented 2026 present value dollars (2026 PV\$) in Table 50.

The LSC hourly factors methodology allows peak electricity savings to be valued more than electricity savings during non-peak periods.

Table 60: 2026 PV LSC Savings Over 30-Year Period of Analysis – Per Square Foot – New Construction and Additions– Laboratory

Climate Zone	30-Year LSC Electricity Savings (2026 PV\$)	30-Year LSC Natural Gas Savings (2026 PV\$)	Total 30-Year LSC Savings (2026 PV\$)
2	6.44	9.21	15.66
3	11.62	14.73	26.35
7	25.36	34.47	59.83
12	10.38	17.97	28.35

5.4.3 Incremental First Cost

4-Pipe VAV was priced by mechanical contractors as an add alternate on two recent lab projects designed by Taylor Engineers. The base design was 2-pipe VAV reheat.

5.4.3.1 Project San Francisco

The alternative system design eliminates cooling at the AHU and instead provides cooling at each VAV box (VAV boxes serving lab spaces are often referred to as lab air valves). The AHU coil is reduced to 4 rows (from 8 rows) since it is used only for heating. At the zone level, coils are increased to 8 rows (from 2 rows) but increased in size so that overall system pressure drop is similar between the two systems. Overall cooling loads are reduced by ~50 tons because supply air temperature at each coil is determined by zone load so that hood and ventilation dominated labs are not

overcooled then reheated. The eliminated reheat at these zones reduced boiler capacity by ~600 kBtu/h. HW piping is further reduced by the large zone coils which have a ~60°F ΔT (vs. 40°F for the base design)

Changes from baseline (2-pipe) to proposed case (4-pipe) include the following:

- Changes that make the base case less expensive:
 1. Chillers downsized from (2) 210 ton to (2) 185-ton chillers.
 2. Downsized CHW pumps from 2 @ 255 GPM to 2 @ 230 GPM
 3. AHU coil reduced from 8 rows to 4 rows (because no cooling needed at AHU)
 4. Eliminated CHW piping to AHU.
 5. Downsized HW piping, including mains, risers, taps on each floor.
 6. Changes that make the base case less expensive:
- 7. Changes that make the base case more expensive:
 8. Added CHW piping to zones.
 9. Increased zone coils from 2-row to 8-row
 10. Added condensate drain pans to zone coils and condensate drain lines from drain pans to nearest discharge location.
 11. Converted zone valves from 2-way HW valves to 6-way changeover valves.

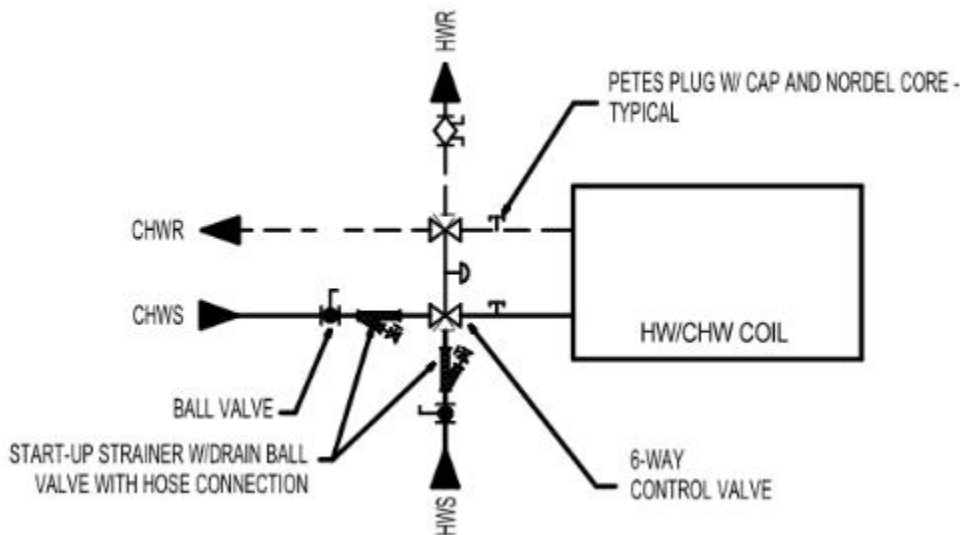

Figure 19: 6-Way changeover valve piping schematic.

Table 61 shows the incremental cost for this project. The pricing from the contractor included reducing the boiler size. After receiving feedback from stakeholders questioning the boiler reduction we added back the boiler reduction savings, i.e., no credit is taken for boiler reduction. Also, the pricing for this project was received in 2019 so a five percent annual inflation escalation was used to bring it up to 2023 pricing.

Table 61: Incremental First Cost for 4-Pipe VAV at Project SF

HVAC Removed Equipment/Installations	\$	(1,537,800)
HVAC Added Equipment/Installations	\$	2,291,300
Electrical Removed Equipment/Installations	\$	(88,300)
Electrical Added Equipment/Installations	\$	88,300
Plumbing Removed Equipment/Installations		0
zones		245
condensate piping per zone	\$	3,027
Plumbing Added Equipment/Installations	\$	741,615
reduction in boiler capacity (btuh)		1,000,000
boiler cost/btuh	\$	0.04
add back boiler reduction (\$)	\$	40,000
subtotal 2019	\$	1,535,115
avg annual inflation since 2019		5%
subtotal 2023	\$	1,865,942
building area (ft2)		154,975
incremental cost/ft2	\$	12.04
incremental maint (\$/yr)	\$	-
maint NPV multiplier		19.6
NPV maintenance	\$	-
incremental cost/ft2	\$	12.04

5.4.3.2 Project Pleasanton

Project Pleasanton is a 100,000 ft² lab/office building in Pleasanton CA with 50,000 ft² dedicated to lab spaces which are served by dedicated lab HVAC systems.

The contractor who provided this alternate design determined that it was slightly less expensive to use separate cooling and heating coils at each zone, rather than a single change-over coil.

Table 62: Incremental First Cost for 4-pipe VAV at Project Pleasanton

lab area/floor	16,878				
lab floors	3				
lab area	50,634				
lab zones/floor	24				
lab zones	72				
fraction of labs w/ cond pump	50%				
	2pVAV (current)	4pVAV	incr. equip cost	incr. labor cost	total incr. cost
CH-1 tons	165	145			\$ (36,967)
CH-2 tons	191	168			\$ (42,792)
CHWP-1 gpm	210	185	\$ (1,138)	\$ (1,706)	\$ (2,844)
CHWP-2 gpm	210	185	\$ (1,138)	\$ (1,706)	\$ (2,844)
delete cooling coil from AHU-1					\$ (80,000)
reduce AHU-1 supply fan array from 5.25" TSP to 4.75"			\$ (9,646)	\$ (14,469)	\$ (24,114)
delete CHW piping to AHU-1			\$ (15,300)	\$ (20,700)	\$ (36,000)
HWP-1 gpm	91	60	\$ (1,399)	\$ (2,099)	\$ (3,499)
HWP-2 gpm	91	60	\$ (1,399)	\$ (2,099)	\$ (3,499)
downsize HW distribution piping					\$ (6,228)
Add CHW piping risers			\$ 16,900	\$ 75,600	\$ 74,000
Add CHW piping to 5th Floor zones			\$ 58,200	\$ 86,400	\$ 144,600
CHW piping to 3 floors of zones					\$ 433,800
unit price to increase zone coils from 2-row to 8-row					\$ 2,020
unit price for condensate pan and condensate drain piping per zone			\$ 250	\$ 2,250	\$ 2,500
option 1: unit price to convert 2-way reheat valves to 6-way valves					\$ 3,750
option 2: unit price to upgrade from (1) coil/box to (2) coil/box, with alt. coil trim					\$ 2,800
zone costs					\$ 527,019
unit price for condensate pump, incl monitoring of high water switch					\$ 800
condensate pumps					\$ 28,800
NPV annual maint \$/ft2					\$ -
total cost					\$ 824,834
total cost/ft2					\$ 16.29

5.4.4 Incremental Maintenance and Replacement Costs

Mechanical service contractors indicated there are no incremental maintenance and replacement costs for 4-pipe VAV vs 2-pipe VAV.

5.4.5 Cost Effectiveness

This measure proposes a primary prescriptive requirement. As such, a cost analysis is required to demonstrate that the measure is cost effective over the 30-year period of analysis.

The CEC establishes the procedures for calculating cost effectiveness. The Statewide CASE Team collaborated with CEC staff to confirm that the methodology in this report is consistent with their guidelines, including which costs were included in the analysis. The incremental first cost and incremental maintenance costs over the 30-year period of analysis were included. The LSC Savings from electricity and natural gas savings were also included in the evaluation. Design costs were not included nor were the incremental costs of code compliance verification.

According to the CEC’s definitions, a measure is cost effective if the benefit-to-cost (B/C) ratio is greater than 1.0. The B/C ratio is calculated by dividing the cost benefits realized over 30 years by the total incremental costs, which includes maintenance costs for 30 years. The B/C ratio was calculated using 2026 PV costs and cost savings. Results of the per-unit cost-effectiveness analyses are presented in Table 53.

The proposed measure saves money over the 30-year period of analysis relative to the existing conditions. The proposed code change is cost effective in Climate Zones 2, 7, and 12. The Statewide CASE Team will expand the analysis to all 16 climate zones in the final draft.

Table 63: 30-Year Cost-Effectiveness Summary Per Square Foot – New Construction, Additions, and Alterations

Climate Zone	Benefits LSC Savings + Other PV Savings ^a (2026 PV\$)	Costs Total Incremental PV Costs ^b (2026 PV\$)	Benefit-to-Cost Ratio
2	15.66	15.47	1.01
3	26.35	15.47	1.70
7	59.83	15.47	3.87
12	28.35	15.47	1.83

- a. **Benefits: LSC Savings + Other PV Savings:** Benefits include LSC Savings over the period of analysis (California Energy Commission 2022). Other savings are discounted at a real (nominal – inflation) three percent rate. Other PV savings include incremental first-cost savings if proposed first cost is less than current first cost, incremental PV maintenance cost savings if PV of proposed maintenance costs is less than PV of current maintenance costs, and incremental residual value if proposed residual value is greater than current residual value at end of CASE analysis period.
- b. **Costs: Total Incremental Present Valued Costs:** Costs include incremental equipment, replacement, and maintenance costs over the period of analysis. Costs are discounted at a real (inflation-adjusted) three percent rate and if PV of proposed maintenance costs is greater than PV of current maintenance costs. If incremental maintenance cost is negative, it is treated as a positive benefit. If there are no total incremental PV costs, the B/C ratio is infinite.

5.5 First-Year Statewide Impacts

5.5.1 Statewide Energy and Energy Cost Savings

The Statewide CASE Team calculated the first-year statewide savings for new construction and additions by multiplying the per-unit savings, which are presented in Section 2.3.2, by assumptions about the percentage of newly constructed buildings that would be impacted by the proposed code. The statewide new construction forecast for 2026 is presented in Appendix A, as are the Statewide CASE Team’s assumptions about the percentage of new construction that would be impacted by the proposal (by climate zone and building type).

The first-year energy impacts represent the first-year annual savings from all buildings that were completed in 2026. The 30-year energy cost savings represent the energy cost savings over the entire 30-year analysis period. The statewide savings estimates do not take naturally occurring market adoption or compliance rates into account.

The table below presents the first-year statewide energy and energy cost savings from newly constructed buildings (Table 54) by climate zone. Table 65 presents first-year statewide savings from new construction, additions, and alterations.

The Statewide CASE Team calculated the statewide impacts by multiplying the per-unit energy savings by the 2026 new construction forecast for labs.

This draft report presents results for Climate Zones 2, 3, 7, and 12. The proposal will apply to all climate zones, and results for the remaining climate zones will be presented in the final CASE Report. The statewide savings estimates are underestimated for the draft report because savings from the remaining climate zones are not accounted for yet.

Table 64: Statewide Energy and Energy Cost Impacts – New Construction and Additions

Climate Zone	Statewide New Construction and Additions Impacted by Proposed Change in 2026 (Million Square Feet)	First-Year ^a Electricity Savings (GWh)	First-Year Peak Electrical Demand Reduction (MW)	First-Year Natural Gas Savings (Million Therms)	First-Year Source Energy Savings (Million kBtu)	30-Year Present Valued Energy Cost Savings (Million 2026 PV\$)
2	139,677	0.19	0.01	0.03	2.59	\$2.19
3	940,564	2.16	0.17	0.29	28.19	\$24.78
7	195,234	0.92	0.09	0.13	13.47	\$11.68
12	315,980	0.61	0.06	0.12	11.52	\$8.96

a. First-year savings from all buildings completed statewide in 2026.

Table 65: Statewide Energy and Energy Cost Impacts – Alterations

Climate Zone	Statewide New Construction and Additions Impacted by Proposed Change in 2026 (Million Square Feet)	First-Year ^a Electricity Savings (GWh)	First-Year Peak Electrical Demand Reduction (MW)	First-Year Natural Gas Savings (Million Therms)	First-Year Source Energy Savings (Million kBtu)	30-Year Present Valued Energy Cost Savings (Million 2026 PV\$)
2	145,964	0.19	0.01	0.03	2.71	\$2.29
3	1,344,252	3.08	0.24	0.41	40.29	\$35.42
7	625,716	2.96	0.28	0.43	43.18	\$37.43
12	441,896	0.85	0.08	0.17	16.11	\$12.53

a. First-year savings from all buildings completed statewide in 2026.

5.5.2 Statewide Greenhouse Gas (GHG) Emissions Reductions

The Statewide CASE Team calculated avoided GHG emissions associated with energy consumption using the hourly GHG emissions factors that CEC developed along with the 2025 LSC hourly factors and an assumed cost of \$123.15 per metric tons of carbon dioxide equivalent emissions (metric tons CO₂e).

The 2025 LSC hourly factors used in the lifecycle cost-effectiveness analysis include the monetary value of avoided GHG emissions based on a proxy for permit costs (not social costs).³⁹ The cost-effectiveness analysis presented in Section 2.4 of this report does not include the cost savings from avoided GHG emissions. To demonstrate the cost savings of avoided GHG emissions, the Statewide CASE Team disaggregated the value of avoided GHG emissions from the other economic impacts. The authors used the same monetary values that are used in the LSC hourly factors.

Table 66 presents the estimated first-year avoided GHG emissions of the proposed code change. During the first year, GHG emissions of 235 (metric tons CO₂e) would be avoided.

Again, this draft report presents results for Climate Zones 2, 3, 7, and 12. The proposal will apply to all climate zones, and results for the remaining climate zones will be presented in the final CASE Report. The statewide savings estimates are underestimated for the draft report because savings from the remaining climate zones are not accounted for yet.

³⁹ The permit cost of carbon is equivalent to the market value of a unit of GHG emissions in the California Cap-and-Trade program, while social cost of carbon is an estimate of the total economic value of damage done per unit of GHG emissions. Social costs tend to be greater than permit costs. See more on the Cap-and-Trade Program on the California Air Resources Board website: <https://ww2.arb.ca.gov/our-work/programs/cap-and-trade-program>.

Table 66: First-Year Statewide GHG Emissions Impacts

Measure	Electricity Savings ^a (GWh/yr)	Reduced GHG Emissions from Electricity Savings ^a (Metric Tons CO ₂ e)	Natural Gas Savings ^a (Million Therms/yr)	Reduced GHG Emissions from Natural Gas Savings ^a (Metric Tons CO ₂ e)	Total Reduced GHG Emissions ^a (Metric Ton CO ₂ e)	Total Monetary Value of Reduced GHG Emissions ^b (\$)
Reheat Limitation	10.949	728	1.60	8,738	9,466	1,165,739

- a. First-year savings from all buildings completed statewide in 2026.
- b. GHG emissions factors are included in the LSC hourly factors published by CEC.

5.5.3 Statewide Water Use Impacts

The proposed code change would not result in water savings.

5.5.4 Statewide Material Impacts

The proposed code change would not result in no material impact.

6. Addressing Energy Equity and Environmental Justice

The Statewide CASE Team recognizes, acknowledges, and accounts for a history of prejudice and inequality in disproportionately impacted populations (DIPs) and the role this history plays in the environmental justice issues that persist today. While the term disadvantaged communities (DACs) is often used in the energy industry and state agencies, the Statewide CASE Team chose to use terminology that is more acceptable to and less stigmatizing for those it seeks to describe. Similar to the California Public Utilities Commission (CPUC) definition, DIPs refer to the populations throughout California that “most suffer from a combination of economic, health, and environmental burdens. These burdens include poverty, high unemployment, air and water pollution, presence of hazardous wastes, as well as high incidence of asthma and heart disease” (CPUC n.d.). DIPs also incorporate race, class, and gender since these intersecting identity factors affect how people frame issues, interpret, and experience the world.⁴⁰

Including impacted communities in the decision-making process, ensuring that the benefits and burdens of the energy sector are evenly distributed, and facing the unjust legacies of the past all serve as critical steps to achieving energy equity. Recognizing the importance of engaging DIPs and gathering their input to inform the code change process and proposed measures, the Statewide CASE Team is working to build relationships with community-based organizations (CBOs) to facilitate meaningful engagement. A participatory approach allows individuals to address problems, develop innovative ideas, and bring forth a different perspective. Please reach out to DJ Joh (djoh@energy-solution.com) and Marissa Lerner (mlerner@energy-solution.com) for further engagement.

Based on a preliminary review, the proposals for laboratories are unlikely to have significant impacts on energy equity or environmental justice or impact DIPs more significantly than the general population. The Statewide CASE Team is still in the process of impacts of the proposed code changes on DIPs. Final results of this research will be incorporated into the Final CASE Report.

⁴⁰ Environmental disparities have been shown to be associated with unequal harmful environmental exposure correlated with race/ethnicity, gender, and socioeconomic status. For example, chronic diseases, such as respiratory diseases, cardiovascular disease, and cancer, associated with environmental exposure have been shown to occur in higher rates in the LGBTQ+ population than in the cisgender, heterosexual population (Goldsmith and Bell 2021). Socioeconomic inequities, climate, energy, and other inequities are inextricably linked and often mutually reinforcing.

7. Proposed Revisions to Code Language

7.1 Guide to Markup Language

The proposed changes to the standards, Reference Appendices, and the ACM Reference Manuals are provided below. Changes to the 2022 documents are marked with red underlining (new language) and ~~strikethroughs~~ (deletions).

7.2 Standards

SECTION 100.0 – SCOPE

- (a) Buildings Covered. The provisions of Part 6 apply to all buildings:
1. That are of Occupancy Group A, B, E, F, H, I, M, R, S, ~~or~~ U, or L; and

SECTION 100.1 – DEFINITIONS AND RULES OF CONSTRUCTION

NONRESIDENTIAL BUILDING is any building which is identified in the California Building Code Table; Description of Occupancy as Group A, B, E, F, H, I, L, M, ~~or~~ S, or L and is a U; as defined by Part 2 of Title 24 of the California Code of Regulation.

NOTE: Requirements for high-rise residential buildings and hotels/motels are included in the nonresidential sections of Part 6.

LABORATORY. A room, building or area where the use and storage of hazardous materials are utilized for testing, analysis, instruction, research or developmental activities.

SECTION 140.4 – PRESCRIPTIVE REQUIREMENTS FOR SPACE CONDITIONING SYSTEMS

- (c) **Fan systems.** Each fan system moving air into, out of or between conditioned spaces or circulating air for the purpose of conditioning air within a space shall meet the requirements of Items 1, 2 and 3 below.
- a. **Fan power budget.** For each fan system that includes at least one fan or fan array with fan electrical input power ≥ 1 kW, fan system electrical input power (Fan kW_{design,system}) determined per Section 140.4(c)1(B) at the fan system design airflow shall not exceed Fan kW_{budget} as calculated per Section 140.4(c)1(A).

EXCEPTION 1 to Section 140.4(c)1: Exhaust fan systems serving laboratory spaces where the exhaust airflow rate exceeds 10,000 cfm complying with 140.9(c)3.

SECTION 140.9 – PRESCRIPTIVE REQUIREMENTS FOR COVERED PROCESSES

c) **Prescriptive requirements for** laboratory exhaust systems.

1. **Airflow reduction requirements.** buildings with laboratory exhaust systems ~~where the minimum circulation rate to comply with code or accreditation standards is 10 ACH or less, the design exhaust airflow~~ shall be capable of reducing zone exhaust and makeup airflow rates to the occupied and unoccupied minimum exhaust airflow rates to the regulated minimum circulation rate, or the minimum required to maintain pressurization requirements, whichever is larger. Variable based on demand and sensed occupancy as follows:

A. Occupied Minimum Exhaust Airflow. When occupant sensing controls sense occupants in the space, the minimum exhaust and makeup airflow rates shall be the greater of:

- i. Not to exceed 1.0 cfm/ft² (equivalent to 6 air changes per hour for a 10-foot-high ceiling), or
- ii. the regulated minimum occupied circulation rate to comply with code, accreditation, or facility environmental health and safety department requirements, or
- iii. the minimum needed to maintain occupied pressurization.

B. Unoccupied Minimum Exhaust Airflow. Within 20 minutes of no occupancy being detected by any occupant sensors covering the space, the minimum exhaust and makeup airflow rates shall be the greater of:

- i. Not to exceed 0.67 cfm/ft² (equivalent to 4 air changes per hour for a 10-foot-high ceiling), or
- ii. the regulated minimum unoccupied circulation rate to comply with code, accreditation, or facility environmental health and safety department requirements, or
- iii. the minimum needed to maintain unoccupied pressurization.

~~**Exception 1 to Section 140.9(c)1:** Laboratory exhaust systems serving zones where constant volume is required by the authority having jurisdiction, facility environmental health & safety department or other applicable code.~~

Exception 2 to Section 140.9(c)1: New zones on an existing constant volume exhaust system.

140.9(c)2 Exhaust System Transfer Air. Conditioned supply delivered to any space with mechanical exhaust shall comply with the requirements of Section 140.4(o).

140.9(c)3 Fan System Power Consumption. All newly installed fan exhaust systems serving a laboratory or factory with a design exhaust fan system airflow rate greater than 10,000 cfm, shall meet subsection A and either B, C, or D: Exhaust air includes all indoor air and gases removed by the exhaust system including exhaust air from fume hoods, hazardous exhaust flows, other manifolded exhaust streams. Exhaust fan system airflow rate is the total of the airflow rates entering the exhaust fans which includes exhaust air and bypass air but does not include entrained or induced airflow downstream of the exhaust fans.

- A. Systems serving laboratory spaces shall meet all discharge requirements in ANSI Z9.5-2022 Section 6.4
- B. The exhaust fan system power shall not exceed 0.85 watts per cfm of exhaust fan system airflow for systems with air filtration, scrubbers, or other air treatment devices. For all other exhaust fan systems the system power shall not exceed 0.65 watts per cfm of exhaust fan system airflow. Exhaust fan system power equals the sum of the power of all fans in the exhaust system that are required to operate at normal occupied design conditions in order to exhaust air from the conditioned space to the outdoors. ~~Exhaust air does not include entrained air, but does include all exhaust air from fume hoods, hazardous exhaust flows, or other manifolded exhaust streams.~~

~~**EXCEPTION to Section 140.9(c)3B:** Laboratory exhaust systems where applicable local, state, or federal exhaust treatment requirements specify installation of air treatment devices that cause more than 1 in. of water pressure drop.~~

- C. Exhaust system shall comply with all of the following:
 - i. The sum of the occupied minimum circulation rates of the spaces served by the fan system shall be less than 60% of the exhaust fan system design airflow rate.
 - ii. The design exhaust fan system power shall not exceed 1.3 watts per cfm of exhaust fan system airflow when operating under full load design conditions.
 - iii. The system shall include variable speed controls so that exhaust system fans shall draw no more than 40% of the design fan power when the exhaust fan system airflow is 60% of the design airflow rate.
 - iv. The exhaust fan system airflow rate shall not exceed the larger of:
 - a) The sum of the space exhaust airflow rates served by the system,
or
 - b) The minimum acceptable exhaust fan system airflow rate
 - v. The minimum acceptable exhaust air flow rate, using the procedures and system definitions included in ANSI Z9.5 (2022) Appendix 3, shall be one of the following:
 - a) Less than 60% of the exhaust fan system design airflow rate (simple turndown control system), or

- b) dynamically reset based on measured wind speed and/or wind direction and assumes worst case emissions rate and shall be less than 60% of the exhaust fan system design airflow rate for at least 70% of the hours during a Typical Meteorological Year (TMY) for the site (wind responsive control system); or
 - c) dynamically reset based on measured contaminant concentration and shall be less than 60% of the exhaust fan system design airflow rate when measured contaminants in the exhaust system plenum are below the threshold contaminant concentration value (monitored control system)
 - vi. Exhaust system design and control results in calculated outdoor contaminant concentrations in compliance with applicable federal, state, or local regulations
 - vii. Before an occupancy permit is granted for a laboratory subject to Section 140.9(c)3C, the applicable equipment and systems shall be certified as meeting the Acceptance Requirements for Code Compliance, as specified by the Reference Nonresidential Appendix NA7.16. A Certificate of Acceptance shall be submitted to the enforcement agency that certifies that the equipment and systems meet the acceptance requirements specified in NA7.16.
- D. The exhaust fan system electrical input power (Fan kW_{design.system}) determined per Section 140.4(c)1(B) at the fan system design airflow does not exceed Fan kW_{budget} as calculated per Section 140.4(c)1(A)
- C. ~~The volume flow rate at the stack shall vary based on the measured 5-minute averaged wind speed and wind direction obtained from a calibrated local anemometer.~~
- ~~i. At least one sonic anemometer or at least two anemometers of other types shall be installed in a location that experiences similar wind conditions to the free stream environment above the exhaust stacks and be at a height that is outside the wake region of nearby structures.~~
 - ~~ii. Look-up tables shall be used to define the required exhaust volume flow rate, as a function of at least eight wind speeds and eight wind directions, to maintain downwind concentrations below health and odor limits, as defined by the 2018 American Conference of Governmental Industrial Hygienists Threshold Limit Values and Biological Exposure Indices, for all contaminants, or as defined by applicable local, state, or federal jurisdictions, if more stringent.~~
 - ~~iii. Wind speed/direction sensors shall be certified by the manufacturer to be accurate within plus or minus 40 fpm (0.2 m/s) and 5.0 degrees when measured at sea level and 25°C, factory calibrated, and certified by the manufacturer to require calibration no more frequently than once every 5 years.~~
 - ~~iv. Upon detection of anemometer and/or signal failure, the system shall reset the exhaust volume flow rate to the value needed to maintain downwind concentrations below health and odor limits for all contaminants at worst-case wind conditions and shall report the fault to an Energy Management Control System (EMCS) or fault management application which automatically provides notification of the fault to a remote system provider. The EMCS or fault~~

~~management system shall log the error and the time when it occurred. The system shall have logic that automatically checks for anemometer failure by the following means:~~

- ~~a. If any anemometer has not been calibrated within the manufacturer's recommended calibration period, the anemometer has failed.~~
- ~~b. During unoccupied periods the system compares the readings of all anemometers. If any anemometer is more than 30% above or below the average reading for a period of 4 hours, the anemometer has failed.~~
- ~~c. Wind speed and wind direction readings shall be sampled at least 10 times per minute. If the difference between the maximum and minimum readings from the average of either the wind direction or the wind speed over a one minute period is less than 10% of the average value, the measurements shall be considered a signal failure.~~
- ~~d. Other error signals sent by the anemometer.~~
- ~~v. Before an occupancy permit is granted for a laboratory or process facility subject to Section 140.9(c)3C, the applicable equipment and systems shall be certified as meeting the Acceptance Requirements for Code Compliance, as specified by the Reference Nonresidential Appendix NA7.16. A Certificate of Acceptance shall be submitted to the enforcement agency that certifies that the equipment and systems meet the acceptance requirements specified in NA7.16.~~
- ~~D. The volume flow rate at the stack shall vary based on the measured contaminant concentration in the exhaust plenum from a calibrated contaminant sensor installed within each exhaust plenum.~~
 - ~~i. A contaminant event threshold shall be established based on maintaining downwind concentrations below health and odor limits for all chemicals at worst-case wind conditions, as defined by the 2018 American Conference of Governmental Industrial Hygienists Threshold Limit Values and Biological Exposure Indices, or as defined by applicable local, state, or federal jurisdictions, if more stringent.~~
 - ~~ii. At least two contaminant concentration sensors shall be Photo Ionization Detectors (PID) certified by the manufacturer to be accurate within plus or minus 5% when measured at sea level and 25°C, factory calibrated, and certified by the manufacturer to require calibration no more frequently than once every 6 months.~~
 - ~~iii. Upon detection of sensor and/or signal failure, the system shall reset the exhaust volume flow rate to the value needed to maintain downwind concentrations below health and odor limits for all contaminants at worst-case wind conditions and shall report the fault to an Energy Management Control System or fault management application which automatically provides notification of the fault to a remote system provider. The system shall have logic that automatically checks for sensor failure by the following means:~~
 - ~~a. If any sensor has not been calibrated within the manufacturer's recommended calibration period, the sensor has failed.~~

~~b. During unoccupied periods the system compares the readings of all sensors. If any sensor is more than 30% above or below the average reading for a period of 4 hours, the sensor has failed.~~

~~iv. Before an occupancy permit is granted for a laboratory or process facility subject to Section 140.9(c)3D, the applicable equipment and systems shall be certified as meeting the Acceptance Requirements for Code Compliance, as specified by the Reference Nonresidential Appendix NA7.16. A Certificate of Acceptance shall be submitted to the enforcement agency that certifies that the equipment and systems meet the acceptance requirements specified in NA7.16.~~

140.9(c)4 Fume Hood Automatic Sash Closure. Variable

140.9(c)5 Reheat Limitation. Air handlers in buildings with greater than 20,000 cfm of laboratory exhaust that serve multiple space conditioning zones in laboratory spaces shall not include mechanical cooling and each zone shall include heating and cooling capacity, such as 4-pipe VAV, to prevent cooling at the air handler and reheating at the zones.

Exception 1 to Section 140.9(c)5: Additions or alterations to existing air handling systems serving existing zones without heating and cooling capacity.

Exception 2 to Section 140.9(c)5: Systems in Climate Zones 7 or 15 or locations where the outdoor dew point temperature is greater than or equal to 66°F at the ASHRAE 2% annual dehumidification design condition.

Exception 3 to Section 140.9(c)5: Systems dedicated to vivarium spaces or to spaces classified as Biosafety Level 3 or higher.

140.9(c)6 Exhaust Air Heat Recovery. Buildings with greater than 10,000 cfm of laboratory exhaust shall include an exhaust air heat recovery system that meets the following:

1. A sensible energy recovery ratio of at least 45% at heating design conditions and 25% at cooling design conditions
2. Heat is recovered from at least 75% of all lab exhaust air volume.
3. The system includes a run-around coil pump or other means to disable heat recovery.

4. The system includes a bypass damper or other means so that the exhaust air pressure drop through the heat exchanger does not exceed 0.4" w.g when heat recovery is disabled.

Exception 1 to Section 140.9(c)6: Additions or alterations to existing laboratory exhaust systems that do not include exhaust air heat recovery.

Exception 2 to Section 140.9(c)6: Buildings where the total laboratory exhaust rate exceeds 20 cfm/ft² of roof area.

Exception 3 to Section 140.9(c)6: Buildings in Climate Zones 6 or 7 in jurisdictions where gas heating is allowed.

Exception 4 to Section 140.9(c)6: Buildings with an exhaust air heat recovery system and heat recovery chillers designed to provide at least 40% of the peak heating load from exhaust heat recovery.

Exception 5 to Section 140.9(c)6: Exhaust systems requiring wash down systems such as exhaust systems dedicated to perchloric acid fume hoods.

SECTION 141.1 – REQUIREMENTS FOR COVERED PROCESSES IN ADDITIONS, ALTERATIONS TO EXISTING NONRESIDENTIAL, AND HOTEL/MOTEL BUILDINGS

Covered processes in additions or alterations to existing buildings that will be nonresidential, and hotel/motel occupancies shall comply with the applicable subsections of section 120.6 and 140.9.

- (a) **Lab and Process Facility Exhaust Systems.** ~~All newly installed fan systems for a laboratory or process facility exhaust system greater than 40,000-cfm~~ Additions, alterations, and repairs to existing laboratories and factories shall meet the requirements of Section 140.9(c).

7.3 Reference Appendices

NA 7.16 Lab Exhaust Ventilation System Acceptance Test

NA7.16.1 Construction Inspection for VAV Lab Exhaust System with Occupancy Control, per 140.9(c)1 and 140.9(c)3

Verify and document the following prior to functional testing:

- (a) Test and balance report confirms correspondence between design values on plans and specification and measured values to within 10%:
1. Area and volume of each lab space
 2. Design airflow rate of each lab spaces, (cfm)
 3. Occupied minimum airflow rate of each lab space, (cfm)
 4. Unoccupied minimum airflow rate of each lab space (cfm)

5. Design inlet airflow rate of exhaust fan system, (cfm)
 6. Power of exhaust fan system at design conditions, (Watts)
 7. Calculate watts/cfm at design conditions. Item (a)6 divided by item (a)5.
- (b) Listing of fume hoods design airflow rate by VAV (variable air volume) vs CV (constant volume) by space. When the total design airflow rate of fume hoods is greater than the unoccupied minimum airflow rate of the space, all the fume hoods in the space shall be VAV.
- (c) Pressure independent flow control valves are used.
- (d) Document whether system has air filtration, scrubbers, or other air treatment devices.
- (e) Description of what type fan control is used: none, simple turndown, wind responsive, contaminant monitoring.
1. If control is “none,” and system has one of the filtration methods in item (d), watts per cfm in item (a)7 shall be no greater than 0.85 watts per cfm of exhaust fan system airflow or rated fan power does not exceed Fan kW_{budget} as calculated per Section 140.4(c)1(A)
 2. If control is “none,” and system does not have one of the filtration methods in item (d), watts per cfm in item (a)7 shall be no greater than 0.65 watts per cfm of exhaust fan system airflow or rated fan power does not exceed Fan kW_{budget} as calculated per Section 140.4(c)1(A).
 3. If control is “simple turndown,” “wind responsive,” or “contaminant monitoring,” exhaust fan system watts per cfm in item (a)7 shall be no greater than 1.3 watts per cfm of exhaust fan system airflow, and fan system shall comply with the applicable acceptance testing requirements in Nonresidential Reference Appendices NA7.16.3 through NA7.16.8.

NA7.16.2 Functional Testing for VAV Lab Exhaust System with Occupancy Control, per 140.9(c)1

If control signals have been calibrated to measured flow rates and power consumption, recorded control signals are acceptable methods of measurement.

Step 1: Simulate design conditions by opening all fume hood sashes other exhaust devices such as snorkels to their design open position and occupying all lab spaces served by the exhaust fan system.

- (a) Verify that the occupant sensors can detect occupants in all portions of the spaces and are reporting occupied occupancy status to controller.
- (b) Verify the inlet airflow rate of the exhaust fans. If the airflow rate is less than 90 percent or greater than 110 percent of the design flowrate, adjust airflow rate before retesting system.
- (c) Verify fan power under design conditions.
- (d) Measured power under design conditions shall be no greater than 110 per cent of design fan power

Step 2: Simulate minimum flowrate under occupied conditions by closing all fume hood sashes to their minimum position, close other exhaust devices such as snorkels and occupy all lab spaces served by the exhaust fan system. Adjust the thermostatic control so that the space temperature is within the dead band.

- (a) Verify that the occupant sensors can detect occupants in all portions of the spaces and are reporting occupied occupancy status to controller.
- (b) Verify the total exhaust airflow rate of each space. If the airflow rate is less than 90 percent or greater than 110 percent of the minimum allowed occupied flowrate, adjust airflow rate before retesting system.
- (c) Verify fan power under minimum flowrate occupied conditions.
- (d) Measured power under minimum flowrate occupied conditions [Step 3(c)] shall be no greater than measured power under design conditions [Step 2(c)].

Step 3: Simulate minimum flowrate under unoccupied conditions by closing all fume hood sashes to their minimum position, and close other exhaust devices such as snorkels and vacate all lab spaces served by the exhaust fan system for at least 20 minutes so occupant control treats lab spaces as unoccupied. Adjust the thermostatic control so that the space temperature is within the dead band.

- (a) Verify that the occupant sensors are reporting unoccupied occupancy status to controller.
- (b) Verify the total exhaust airflow rate of each space. If the airflow rate is less than 90 percent or greater than 110 percent of the minimum allowed unoccupied flowrate, adjust airflow rate before retesting system.
- (c) Verify fan power under minimum flowrate occupied conditions.
- (d) Measured power under minimum flowrate unoccupied conditions [Step 4(c)] shall be no greater than measured power under minimum flowrate occupied conditions [Step 3(c)].

NA7.16.3 Construction Inspection for Simple Turndown Control, per 140.9(c)3C.v.a

Requirements for simple turndown control are in addition to requirements for VAV Lab Exhaust System with Occupancy Control in NA7.16.1 and NA7.16.2

- (a) Test and balance report confirms correspondence between design values on plans and specification and measured values to within 10%:
 1. Design inlet airflow rate of exhaust fan system, (cfm)
 2. Power of exhaust fan system at design conditions, (cfm)
 3. Inlet airflow rate of exhaust fan system at minimum acceptable airflow rate, (cfm)
 4. Power of exhaust fan system at minimum acceptable airflow rate, (cfm)
 5. Calculate watts/cfm at design conditions. Item (a)2 divided by item (a)1.
- (b) Measured minimum acceptable exhaust fan system inlet airflow rate [item (a)3] is no greater than 60% of measured design exhaust fan system airflow rate [item (a)1]
- (c) Measured exhaust fan system power at minimum acceptable exhaust fan system inlet airflow rate [item (a)4] is no greater than 40% of measured exhaust fan system power at design exhaust fan system airflow rate [item (a)2]
- (d) Measured Watts/cfm shall be no greater 1.3 Watts/cfm.

NA7.16.4 Functional Testing for Simple Turndown Control, per 140.9(c)3C.v.a

If control signals have been calibrated to measured flow rates and power consumption, recorded control signals are acceptable methods of measurement.

Step 1: Simulate design conditions by opening all fume hood sashes other exhaust devices such as snorkels to their design open position and occupying the all lab spaces served by the exhaust fan system.

(a) Verify that the occupant sensors can detect occupants in all portions of the spaces and are reporting occupied occupancy status to controller.

(b) Record exhaust fan system inlet airflow rate, (cfm). If the airflow rate is less than 90 percent or greater than 110 percent of the design flowrate, adjust airflow rate before retesting system.

(c) Record fan system power, (Watts).

Step 2: Simulate low airflow rate under unoccupied conditions by closing all fume hood sashes to their minimum position, and close other exhaust devices such as snorkels and vacate all lab spaces served by the exhaust fan system for at least 20 minutes so occupant control treats lab spaces as unoccupied. Adjust the thermostatic control so that the space temperature is within the dead band.

(a) Verify that the occupant sensors can detect occupants in all portions of the spaces and are reporting unoccupied occupancy status to controller.

(b) Record exhaust fan system inlet airflow rate, (cfm).

(c) Confirm that the entering fan system airflow rate in Step 2(b) is no greater than 60% of the exhaust fan system design airflow rate in Step 1(b), if not fix control before proceeding

(d) Record fan system power (Watts).

(e) If fan system power under low airflow rate during unoccupied periods in Step 2(d) is no greater than 40% of the exhaust fan system design airflow rate in Step 1(c), the system passes. Otherwise, adjust system before retesting.

NA7.16.51 Construction Inspection for Wind Speed/Direction Responsive Control

Requirements for wind speed/direction responsive control are in addition to requirements for VAV Lab Exhaust System with Occupancy Control in NA7.16.1 and NA7.16.2

Verify and document the following prior to functional testing:

- (a) Wind speed and direction sensor is factory-calibrated (with calibration certificate) or field calibrated, as specified by Section 140.9(c)3C.
- (b) The sensor is located in a location and at a height that is outside the wake region of nearby structures and experiences similar wind conditions to the free stream environment above the exhaust stacks as specified by Section 140.9(c)3C.
- (c) The sensor is installed in close proximity to the fan that it will control so that it captures a representative wind speed/direction reading.
- (d) The sensor is wired correctly to the controls to ensure proper control of volume flow rate.
- (e) Wind speed/direction look-up table has been established and matches dispersion analysis results.

- (f) Verify the methodology to measure volume flow rate:
1. Airflow sensor.
 2. Static pressure as proxy.
 3. Fan speed to volume flow rate curve.
 4. Other.

NA7.16.62 Functional Testing for Wind Speed/Direction Responsive Control

Step 1: Simulate the minimum look-up table wind speed by either covering the sensor or overriding the curve points so the current wind speed is below the speed correlating to minimum volume flow rate at the stack.

- (a) With all sensors active and all sensors reading below the minimum wind speed, observe minimum volume flow rate at the stack.
- (b) Restore all curve points.

Step 2: Simulate a mid-range wind speed from the look-up table by either inducing a wind current, with an air speed accuracy of +/- 2%, or overriding the curve points so the current wind speed correlates to a mid-range volume flow rate at the stack.

- (a) With all sensors active and all sensors reading a mid-range wind speed, observe corresponding mid-range volume flow rate at the stack.
- (b) Restore all curve points.

Step 3: Simulate the maximum look-up table wind speed by either inducing a wind current, with an air speed accuracy of +/- 2%, or overriding the curve points so the current wind speed correlates to the maximum volume flow rate at the stack.

- (a) With all sensors active and all sensors reading above the maximum wind speed, observe maximum volume flow rate at the stack.
- (b) Restore all curve points.

Step 4: Temporarily override the programmed sensor calibration/replacement period to 5 minutes. Wait 5 minutes and observe that minimum volume flow rate at the stack is that at worst-case wind conditions and an alarm is received by the facility operators. Restore calibration/replacement period.

Step 5: Simulate sensor failure by disconnecting the sensor. Observe that minimum volume flow rate at the stack is that at worst-case wind conditions and an alarm is received by the facility operators. Reconnect sensor.

NA7.16.73 Construction Inspection for Monitored Contaminant Control

Requirements for monitored contaminant control are in addition to requirements for VAV Lab Exhaust System with Occupancy Control in NA7.16.1 and NA7.16.2

Verify and document the following tests prior to functional testing:

- (a) Contaminant sensor is factory-calibrated (with calibration certificate) or field calibrated, as specified by Section 140.9(c)3D.
- (b) The sensor is located within each exhaust plenum as specified by Section 140.9(c)3D.
- (c) The sensor is wired correctly to the controls to ensure proper control of volume flow rate.

(d) Contaminant concentration threshold has been established and matches dispersion analysis results.

(e) Verify the methodology to measure volume flow rate:

1. Airflow sensor
2. Static pressure as proxy
3. Fan speed to volume flow rate curve
4. Other

(f) If multiple sensors are present, ensure fan is controlled based on the highest concentration reading.

NA7.16.84 Functional Testing For Monitored Contaminant Control

Step 1: Ensure no contaminant event is present. Simulate minimum exhaust air demand in all lab spaces.

Verify that the volume flow rate at the stack is at or above the minimum non-event value.

Step 2: Increase exhaust air demand at the lab spaces.

Verify that the volume flow rate at the stack is at or above the minimum non-event value.

Step 3: Simulate minimum exhaust air demand in all lab spaces. Simulate a contaminant event.

Verify that the volume flow rate at the stack is at or above the minimum event value.

Step 4: Increase exhaust air demand at the lab spaces.

Verify that the volume flow rate at the stack is at or above the minimum event value.

Step 5: Temporarily override the programmed sensor calibration/replacement period to 5 minutes.

Wait 5 minutes and observe that minimum volume flow rate at the stack is that of a contaminant event and an alarm is received by the facility operators. Restore calibration/replacement period.

Step 6: Simulate sensor failure by disconnecting the sensor. Observe that minimum volume flow rate at the stack is that of a contaminant event and an alarm is received by the facility operators. Reconnect sensor.

7.4 ACM Reference Manual

5.1.2 HVAC System Map

For systems 1, 3, 7, 9, 10, and 11, each thermal zone shall be modeled with a respective HVAC system. For systems 5, and 6, each floor shall be modeled with a separate HVAC system. Floors with identical thermal zones and occupancies can be grouped for modeling.

The standard design systems serving mixed-use buildings are different from the standard design systems serving nonresidential space types. Also, spaces containing covered processes are served by dedicated standard design systems separate from systems serving other nonresidential space types.

The standard design building shall have only one central chilled or hot water plant, so if there are multiple systems that incorporate a central plant (for example, CRAH and VAVS), then a single plant shall serve all plant loads.

Space Type	Above-Grade Floors	Climate Zone	System Cooling Capacity	Standard Design
Covered process laboratory with total building laboratory design maximum exhaust < 15,000 cfm and total building area < 25,000 ft²	Buildings ≤ 3 floors <u>No limit</u>	All	No limit	System 7a – SZVAVAC <u>7a – SZVAVHP</u>
Covered process laboratory with total building laboratory design maximum exhaust > 15,000 cfm required to meet 140.9(c)5 Reheat Limitation and total building conditioned floor area 25,000 ft² to < 150,000 ft²	No limit	All	No limit	System 5 – PVAV <u>System 12a – AC4PVAV</u>
Covered process laboratory with total building laboratory design maximum exhaust > 15,000 cfm required to meet 140.9(c)5 Reheat Limitation and total building conditioned floor area ≥ 150,000 ft²	No limit	All	No limit	System 6 – VAV <u>System 12b – WC4PVAV</u>
<u>Covered process laboratory exempt from 140.9(c)5 Reheat Limitation and total building conditioned floor area 25,000 ft² to < 150,000 ft²</u>	<u>No limit</u>	<u>All</u>	<u>No limit</u>	<u>System 5 – PVAV</u>

<u>Covered process laboratory exempt from 140.9(c)5 Reheat Limitation and total building conditioned floor area $\geq 150,000 \text{ ft}^2$</u>	<u>No limit</u>	<u>All</u>	<u>No limit</u>	<u>System 6 – VAV</u>
--	-----------------	------------	-----------------	-----------------------

System Type	Description	Detail
System 5 – PVAV	Packaged VAV	Multi-zone packaged system with variable volume fan, direct expansion cooling, gas furnace heating, and hot water reheat terminal units served by a central gas boiler.
System 6 – VAV	Built-up VAV	Multi-zone built-up system with variable volume fan, chilled water cooling provided by a central water-cooled chiller and cooling tower, and hot water heating provided by a central gas boiler.
System 7a – SZVAVAC	Packaged single-zone variable air volume air conditioner	Single-zone system with variable air volume fan, direct expansion variable-speed drive cooling, and gas furnace heating. Minimum fan speed ratio of 0.2 for laboratory spaces and 0.5 for all other spaces. Integrated economizer for standard design cooling capacities $\geq 33 \text{ kBtu/h}$.
System 7b – SZVAVHP	Packaged single-zone variable air volume heat pump	Single-zone system with variable air volume fan, direct expansion heat pump cooling and heating, and electric resistance supplemental heating. <u>Minimum fan speed ratio of 0.2 for laboratory spaces and 0.5 for all other spaces.</u>

<u>System 12a – AC4PVAV</u>	<u>Air-cooled 4-pipe VAV</u>	<u>Multi-zone built-up system with variable volume fan, chilled water provided by a dedicated air-cooled chiller, and hot water provided by a dedicated air-to-water heat pump. The air handler has a heat recovery coil where required by 140.9(c)6 but no CHW/HW. Each zone has a CHW/HW changeover coil for heating/cooling.</u>
<u>System 12b – WC4PVAV</u>	<u>Water-cooled 4-pipe VAV</u>	<u>Same as 12a except chilled water is provided by the central water-cooled chiller plant.</u>

5.6.6 Terminal Air Flow

Variable Air Volume (VAV) Air Flow

TERMINAL MINIMUM AIRFLOW

Applicability: Systems that vary the volume of air at the zone level

Definition: The minimum airflow that will be delivered by a terminal unit.

Units: Unitless fraction of airflow

Input Restrictions: Input must be greater than or equal to the outside air ventilation rate. [Users may input separate minimum rates for occupied and unoccupied. The unoccupied rates shall be used when the occupancy schedule indicates an occupancy fraction below 0.10.](#)

Standard Design: For systems 5 and 6, packaged VAV units and built-up VAV air handling units, set the minimum airflow to be the maximum of the minimum outside air ventilation rate or 10% of the design airflow.

For laboratories, the [occupied](#) minimum airflow fraction shall be fixed at a value equivalent to the greater of the proposed design [occupied](#) minimum exhaust requirements or the [occupied](#) minimum ventilation rate. [The unoccupied minimum airflow fraction shall be 0.33 cfm/ft² less than the occupied minimum airflow fraction.](#)

5.6.7 Zone Exhaust

ZONE EXHAUST MINIMUM AIR FLOW RATE

Applicability: All laboratory zones.

Definition: Minimum rate of exhaust from a zone.

Units: cfm/ft².

Input Restrictions: As designed for non-process zones.

For laboratory zones, the exhaust air flow rate is the maximum of the hood scheduled exhaust air flow rate and the minimum ventilation rate. A warning is posted if the minimum exhaust rate is 2 ACH or less. Users may shall have the capability to input separate rates for occupied and unoccupied.

Standard Design: For laboratory systems ~~with minimum exhaust flow rates exceeding 10 ACH exhaust, the exhaust minimum air flow rate is equal to the proposed design minimum. For VAV laboratory systems with variable flow and variable speed drive exhaust fan control,~~ the occupied exhaust minimum air flow rate is the proposed design occupied minimum exhaust air flow rate. The unoccupied exhaust minimum air flow rate shall be 0.33 cfm/ft² less than the occupied exhaust minimum airflow rate.

EXHAUST FAN SCHEDULE

Applicability: All thermal zones.

Definition: Schedule indicating the pattern of use for exhaust air from the thermal zone.

Units: Data structure: schedule, fraction.

Input Restrictions: For healthcare facilities, the schedule is the same as the proposed design. For all nonresidential buildings, the schedule is based on the predominant schedule group for the building story or zone. See Chapter 2.3.3 Space Use Classification Considerations for details. For multifamily buildings, see Chapter 6 Multifamily Building Descriptors Reference.

Exhaust schedules for commercial kitchen exhaust and laboratory processes are prescribed in Appendix 5.4B. For laboratory systems ~~if the exhaust is variable flow,~~ the compliance software shall automatically use either the ~~no~~ manual sash control or auto sash control laboratory variable exhaust schedule or a volume-weighted interpolated average of the two schedules if only a fraction of the exhaust hoods have automatic sash control.

Standard Design: Same as the proposed design for non-covered process spaces.

For laboratory spaces, ~~the standard design is constant volume if the proposed exhaust system is constant volume and has a minimum exhaust air flow rate greater than 10 ACH. Otherwise,~~ the standard design is variable volume. If ~~the standard design is variable volume and~~ the proposed laboratory space is fume hood intense (as defined in Table 140.9-~~GD~~ of the Energy Code) then the standard design will use a modified VAV schedule for hoods with sash controls, volume-weighted by the fraction of exhaust that is served by exhaust hoods with vertical-only sashes. If the ~~standard design is variable volume and~~ the proposed space is not fume hood intense, then the standard design shall use the VAV exhaust schedule for manual sash control ~~controlled sashes.~~

5.7.3 Fan and Duct Systems

EXHAUST FAN CONTROL METHOD

Applicability: All exhaust fan systems.

Definition: A description of how the exhaust fan(s) are controlled. The options include:

Constant volume, constant speed fan.

Variable-flow, variable speed fan

For laboratories the options are:

Constant exhaust volume, constant speed fan with bypass damper

Constant exhaust volume, constant speed fan without bypass damper

Variable exhaust volume, constant speed fan with bypass damper

Variable exhaust volume, variable volume fan without bypass damper

Variable exhaust volume, variable volume fan with bypass damper

Units: List (see above)

Input Restrictions: As designed, when exhaust fan flow at the thermal zone level is varied through a schedule, one of the variable-flow options shall be specified.

Standard Design: For healthcare facilities, same as the Proposed Design. For all others, the standard design exhaust fan control shall be the same as the proposed design, but subject to the conditions described above.

For exhaust fans serving laboratory spaces, the fan control method is ~~variable speed drive~~ variable exhaust volume, constant speed fan with bypass damper with a design fan power of 0.65 W/cfm or for filtered exhausts a fan power of 0.85 W/cfm of design airflow entering the motor. The airflow entering the exhaust fans is constant even though the exhausted conditioned airflow from the lab spaces varies in accordance with the larger of schedules of fume hood fraction, minimum ACH (circulation rate), and airflow required for heating and cooling. As exhaust airflow from the lab spaces decreases, bypass air correspondingly increases, and as a result, the airflow out of the stack is constant and the exhaust fan draws design power continuously when it is on-line.

~~when the minimum exhaust flow is 10 ACH or less. If the lab exhaust flow minimum is greater than 10 ACH, the control method is the same as proposed.~~

EXHAUST FAN SYSTEM MINIMUM AIRFLOW RATE

Applicability: All laboratory exhaust fan systems.

Definition: Minimum rate of exhaust from a laboratory fan system.

Units: cfm.

Input Restrictions: As designed for non-process zones.

For laboratory zones, the exhaust fan system air flow rate is the maximum of the sum of the zone exhaust air flow rates served by the exhaust fan system and the minimum fan system airflow rate. The difference between the sum of the zone exhaust air flow rates served by the exhaust fan system and the fan system airflow rate, is bypass air into the inlet of the exhaust fans. For induction fans that also have entrained airflow downstream of the fan, the entrained airflow shall be subtracted off from the total stack airflow when defining the minimum exhaust rate.

Users shall have the capability to input separate fan system minimum rates for high and low periods. High minimum periods correspond to times with wind speeds above user defined threshold velocities by wind direction for wind responsive control systems or above contaminant threshold concentration for contaminant monitoring control systems.

Standard Design: For laboratory systems the occupied exhaust minimum air flow rate is the proposed design occupied minimum exhaust air flow rate. The unoccupied exhaust minimum air flow rate shall be 0.33 cfm/ft² less than the occupied exhaust minimum airflow rate.

5.7.7 Heat Recovery

RECOVERY TYPE

Applicability: All systems with airside heat recovery.

Definition: The type of heat recovery system.

Units: List: sensible, latent, or total (sensible and latent).

Input Restrictions: As designed.

Standard Design: For healthcare facilities, same as the Proposed Design. For all others, sensible if impacted based on requirements in 140.4(q) or 140.9(c)6. Not applicable for all systems.

Standard Design: Existing Buildings: For healthcare facilities, same as the Proposed Design. For all others, sensible if impacted based on requirements in 140.4(q) or 140.9(c)6. Not applicable for all systems.

RECOVERY AIR FLOW RATE

Applicability: All systems with airside heat recovery.

Definition: The design air flow rate through the heat recovery system.

Units: cfm.

Input Restrictions: As designed.

Standard Design: For healthcare facilities, same as the Proposed Design. For all others, assume balanced flow if impacted based on requirements in 140.4(q) or 140.9(c)6. Not applicable for all systems.

Standard Design: Existing Buildings: Assume balanced flow if impacted based on requirements in 140.4(q) or 140.9(c)6. Not applicable for all systems.

EXHAUST AIR SENSIBLE HEAT RECOVERY EFFECTIVENESS

Applicability: Any system with outside air heat recovery.

Definition: The effectiveness of an air-to-air heat exchanger between the building exhaust and entering outside air streams. Effectiveness is defined as:

$$HREFF = \frac{(EEA_{db} - ELA_{db})}{EEA_{db} - OSA_{db}}$$

Where:

HREFF– The air-to-air heat exchanger effectiveness

EEA_{db}– The exhaust air dry-bulb temperature entering the heat exchanger

ELA_{db}– The exhaust air dry-bulb temperature leaving the heat exchanger

OSA_{db}– The outside air dry-bulb temperature

Units: Two unitless numbers (ratio between 0 and 1), separate for cooling and heating.

Input Restrictions: As designed.

Standard Design: For healthcare facilities, same as the Proposed Design. For all others, the sensible effectiveness is 60% if using for HVAC systems impacted based on requirements in 140.4(q) and 45% at heating design conditions and 25% at cooling design conditions if using for HVAC systems impacted based on requirements in 140.9(c)6. Not applicable for all systems.

Standard Design: Existing Buildings: The sensible effectiveness is 60% if using for HVAC systems impacted based on requirements in 140.4(q) and 45% at heating design conditions and 25% at cooling design conditions if using for HVAC systems impacted based on requirements in 140.9(c)6. Not applicable for all systems.

EXHAUST AIR SENSIBLE PART-LOAD EFFECTIVENESS

Applicability: Any system with outside air heat recovery.

Definition: The effectiveness of an air-to-air heat exchanger between the building exhaust and entering outside air streams at 75 percent of design airflow. Effectiveness is defined as:

$$HREFF = \frac{(EEAdb - ELAdb)}{EEAdb - OSAdb}$$

Where:

HREFF– The air-to-air heat exchanger effectiveness

EEAdb– The exhaust air dry-bulb temperature entering the heat exchanger

ELAdb– The exhaust air dry-bulb temperature leaving the heat exchanger

OSAdb– The outside air dry-bulb temperature

Units: Two unitless numbers (ratio between 0 and 1), separate for cooling and heating.

Input Restrictions: As designed.

Standard Design: For healthcare facilities, same as the Proposed Design. For all others, the sensible effectiveness is 65% if using for HVAC systems impacted based on requirements in 140.4(q). Not applicable for all systems.

Standard Design: Existing Buildings: The sensible effectiveness is 65% if using for HVAC systems impacted based on requirements in 140.4(q). Not applicable for all systems.

EXHAUST AIR LATENT HEAT RECOVERY EFFECTIVENESS

Applicability: Any system with outside air enthalpy heat recovery.

Definition: The latent heat recovery effectiveness of an air-to-air heat exchanger between the building exhaust and entering outside air streams. Effectiveness is defined as:

$$HREFF = \frac{(EEAw - ELAw)}{EEAw - OSAw}$$

Where:

HREFF– The air-to-air heat exchanger effectiveness

EEAw– The exhaust air humidity ratio (fraction of mass of moisture in air to mass of dry air) entering the heat exchanger

ELAw– The exhaust air humidity ratio leaving the heat exchanger

OSAw– The outside air humidity ratio

Note: For sensible heat exchangers, this term is not applicable

Units: Two unitless numbers (ratio between 0 and 1), separate for cooling and heating.

Input Restrictions: As designed.

Standard Design: For healthcare facilities, same as the Proposed Design. For all others, not applicable.

Standard Design: Existing Buildings: For healthcare facilities, same as the Proposed Design. For all others, not applicable.

EXHAUST AIR LATENT PART-LOAD EFFECTIVENESS

Applicability: Any system with outside air enthalpy heat recovery.

Definition: The latent heat recovery effectiveness of an air-to-air heat exchanger between the building exhaust and entering outside air streams at 75 percent of design airflow.

Effectiveness is defined as:

$$HREFF = \frac{(EEAw - ELAw)}{EEAw - OSAw}$$

Where:

HREFF— The air-to-air heat exchanger effectiveness

EEAw— The exhaust air humidity ratio (fraction of mass of moisture in air to mass of dry air) entering the heat exchanger

ELAw— The exhaust air humidity ratio leaving the heat exchanger

OSAw - The outside air humidity ratio

Note: For sensible heat exchangers, this term is not applicable.

Units: Two unitless numbers (ratio between 0 and 1), separate for cooling and heating.

Input Restrictions: As designed.

Standard Design: For healthcare facilities, same as the Proposed Design. For all others, not applicable.

ECONOMIZER ENABLED DURING HEAT RECOVERY

Applicability: All systems with airside heat recovery.

Definition: A flag to indicate whether or not the economizer is enabled when heat recovery is active.

Units: Boolean.

Input Restrictions: As designed.

Standard Design: For healthcare facilities, same as the Proposed Design. For all others, the economizer is disabled for HVAC systems impacted based on requirements in 140.4(q). Not applicable for all systems.

Standard Design: Existing Buildings:

The economizer is disabled for HVAC systems impacted based on requirements in 140.4(q). Not applicable for all systems.

7.5 Compliance Forms

Compliance Forms

NRCC-PRC-E Process Systems

Laboratory and Factory Exhaust and Fume Hoods section would have more detail so laboratory HVAC can be compared against the configuration of equipment on the plans. This includes:

- Area and volume of each lab space
- Design airflow rate of each lab spaces, (cfm)
- Occupied minimum airflow rate of each lab space, (cfm)
- Unoccupied minimum airflow rate of each lab space (cfm)
- Design inlet airflow rate of exhaust fan system, (cfm)
- Power of exhaust fan system at design conditions, (Watts)
- Calculated watts/cfm of exhaust fan at design conditions
- Fume hood VAV or CV
- Fume hood minimum and maximum flowrate
- Inlet airflow rate of exhaust fan system at minimum acceptable inlet airflow rate, (cfm)
- Calculated ratio of minimum acceptable inlet flowrate to design inlet airflow rate of exhaust fan system
- Power of exhaust fan system at minimum acceptable airflow rate, (cfm)
- Calculated ratio of fan system power are minimum acceptable flowrate to fan system power at design conditions

Acceptance Test Forms

The acceptance test form NRCA-PRC-14-F “Lab Exhaust Ventilation” would be updated to include two new tests:

- VAV Lab Exhaust System with Occupancy Control corresponding to NA7.16.1 and NA7.16.2. This test is a prerequisite for the other laboratory ventilation acceptance tests.
- Simple Turndown Control corresponding to NA7.16.3 and NA7.16.4

The details of what information would be included in these forms is described in Section 7.3 Reference Appendices of this report.

8. Bibliography

ACGIH 2020. *Industrial Ventilation: A Manual of Recommended Practice for Design*. American Conference of Governmental Industrial Hygienists, 2nd Edition. ISBN:9781607261148.

ANSI/ASSP Standard Z9.5-2022 *Laboratory Ventilation*. American Society of Safety Professionals.

ASHRAE 2019. *ASHRAE Handbook of Applications*. American Society of Heating, Refrigerating, and Air Conditioning Engineers.

Caltech. 2018. *California Institute of Technology Design Guidelines*. Feb 2018. https://dandc.sites.caltech.edu/documents/4179/Design_Guidelines_V4_links_fixed_3-19-2019.pdf

ISL 2021. *Best Practices Guide: Manifolding Laboratory Exhaust Systems*. International Institute for Sustainable Laboratories. May 2021. https://www.i2sl.org/documents/I2SLBestPractices_ManifoldingLaboratoryExhaustSystems_May2021.pdf

Stanford EH&S. *Laboratory Standard & Design Guideline*. Stanford University Environmental Health and Safety. December 15, 2022 <https://ehs.stanford.edu/manual/laboratory-standard-design-guidelines>

NFPA Standard 45-2019 *Standard on Fire Protection for Laboratories Using Chemicals*. National Fire Protection Association.

Steven T. Taylor, *4-Pipe VAV vs. Active Chilled Beams for Labs*, ASHRAE Journal, December 2018

UC Laboratory Safety Design Manual https://www.ucop.edu/safety-and-loss-prevention/_files/lab-safety-design-manual-2007.pdf

UCI Environmental Health & Safety. 2023. *UCI Smart Labs Initiative*. University of California Irvine. <https://ehs.uci.edu/energy/index.php>

Appendix A: Statewide Savings Methodology

The Statewide CASE Team estimated statewide impacts for the first year by multiplying per-unit savings estimates by statewide construction forecasts that the CEC provided (California Energy Commission 2022). The CEC provided the construction estimates on March 27, 2023, at the Staff Workshop on Triennial California Energy Code Measure Proposal Template.

To calculate first-year statewide savings, the Statewide CASE Team multiplied the per-unit savings by statewide construction estimates for the first year the standards will be in effect (2026). The projected nonresidential new construction that will be impacted by the proposed code change in 2026 is presented in

Table 67. The projected nonresidential existing statewide building stock that will be impacted by the proposed code change as a result of alterations in 2026 is presented in Table 68. This section describes how the Statewide CASE Team developed these estimates.

The CEC Building Standards Office provided the nonresidential construction forecast, which is available for public review on the CEC’s website:

<https://www.energy.ca.gov/programs-and-topics/programs/building-energy-efficiency-standards/2025-building-energy-efficiency>.

For Laboratories, the Statewide CASE Team provided several sources that showed a significant increase in the laboratory construction category, which was not captured in the forecast that CEC provided. The sources were evaluated and it was determined that there was a compelling argument for revising the forecasted laboratory floor area. To calculate the increase in laboratory floor area, floor areas from the original forecast were reapportioned using the following methodology:

- For Large School, Large Office, Hospital, and Small Office, floor areas were reapportioned using the portions of floor area from Appendix A of the 2019 Variable Exhaust Flow Control CASE Report. The Hospital prototype already contains a Laboratory space function, comprising 2.4 percent of its floor area. So, the Appendix A proportion for Hospitals was reduced by that amount.
- For manufacturing, the “Mfg Labs” building category in the Dodge data was subtracted out from the Manufacturing forecast category. This value was then multiplied by 33 percent, which is the approximate floor area of research labs in facilities that include both research and manufacturing floor areas. 33 percent is derived from available data sources. The remaining 67 percent stayed in the Manufacturing category.
- There was no change to the existing floor area because the significant increase in labs is considered a relatively recent phenomenon and the Statewide CASE Team data sources contained very similar floor area as that calculated in the original forecast.

The Statewide CASE Team made assumptions about the percentage of newly constructed floorspace that would be impacted by the proposed code change. Table 69 presents the assumed percentage of floorspace that would be impacted by the proposed code change by building type. If a proposed code change does not apply to a specific building type, it is assumed that zero percent of the floorspace would be impacted by the proposal. If the assumed percentage is non-zero, but less than 100 percent, it is an indication that some but not all buildings would be impacted by the proposal. Heat recovery measure does not apply to Climate Zones 6 and 7 because it was not shown to be cost effective in those zones.

Table 67: Estimated New Nonresidential Construction in 2026 (Million Square Feet) by Climate Zone (CZ)

Building Type	CZ 1	CZ 2	CZ 3	CZ 4	CZ 5	CZ 6	CZ 7	CZ 8	CZ 9	CZ 10	CZ 11	CZ 12	CZ 13	CZ 14	CZ 15	CZ 16	All CZs
Large Office	0	0	1.714	1.924	0	0.1903	0.2236	0.4025	0.5248	0.09638	0.0003034	0.6579	0	0.02988	0.0008413	0.01305	5.7775547
Medium Office	0.004068	0.02354	1.068	2.084	0.04461	0.3947	0.3349	0.794	0.6517	0.3835	0.1563	0.5091	0.1137	0.07513	0.0846	0.06194	6.783788
Small Office	0.00516	0.02097	0.08167	0.01496	0.007131	0.03667	0.07125	0.05288	0.07346	0.1287	0.04443	0.1067	0.07617	0.009704	0.02635	0.01637	0.772575
Large Retail	0	0	0.226	0.1196	0.02944	0.1024	0.09893	0.1422	0.2798	0.1968	0.1377	0.4133	0.1053	0.03845	0.0734	0.02796	1.99128
Medium Retail	0.01126	0.0225	0.153	0.09006	0.01495	0.07826	0.06408	0.1311	0.2097	0.234	0.05098	0.1559	0.09886	0.04458	0.04242	0.04161	1.44326
Strip Mall	0.00005181	0.003225	0.03459	0.01637	0.0004897	0.02754	0.04294	0.05616	0.05968	0.1394	0.01097	0.06269	0.03205	0.0285	0.01359	0.009578	0.53782451
Mixed-use Retail	0.0001036	0.006451	0.06918	0.03274	0.0009794	0.05509	0.08587	0.1123	0.1194	0.2788	0.02194	0.1254	0.0641	0.057	0.02717	0.01916	1.075684
Large School	0.0005629	0.06689	0.6955	0.3169	0.05191	0.2702	0.2888	0.4727	0.4883	0.4428	0.1478	0.4711	0.2755	0.06294	0.06431	0.03283	4.1490429
Small School	0.003993	0.03253	0.1271	0.0836	0.03301	0.08298	0.1322	0.1235	0.09393	0.2108	0.02206	0.3141	0.1965	0.02503	0.03967	0.01862	1.539623
Non-refrigerated Warehouse	0.01959	0.4308	1.674	0.5649	0.1164	0.925	0.8792	1.177	1.869	9.657	0.1103	4.516	1.065	2.182	0.9495	0.5811	26.71679
Hotel	0.01459	0.2706	0.5782	0.5283	0.103	0.4521	0.6194	0.8027	0.6871	0.7048	0.1214	0.4476	0.1405	0.08369	0.09831	0.041	5.69329
Assembly	0.001475	0.01882	0.2633	0.03985	0.01659	0.1708	0.1309	0.3305	0.4666	0.1544	0.03561	0.2396	0.04596	0.04153	0.01602	0.01993	1.991885
Hospital	0	0.02657	0.2064	0.008258	0.009954	0.05728	0.1089	0.05465	0.09098	0.2324	0.02427	0.03757	0.03492	0.04556	0.03094	0.01477	0.983422
Laboratory	0.00005395	0.01329	0.3661	0.19	0.007387	0.02838	0.02102	0.04858	0.04015	0.08584	0.002863	0.01665	0.004968	0.003707	0.01938	0.001795	0.85016395
Restaurant	0.0022	0.02084	0.04215	0.02865	0.01629	0.04247	0.03727	0.06191	0.0876	0.0936	0.02503	0.05317	0.02951	0.01847	0.01467	0.008062	0.581892

Building Type	CZ 1	CZ 2	CZ 3	CZ 4	CZ 5	CZ 6	CZ 7	CZ 8	CZ 9	CZ 10	CZ 11	CZ 12	CZ 13	CZ 14	CZ 15	CZ 16	All CZs
Enclosed Parking Garage	0.000257 2	0.06736	1.764	2.16	0.03094	1.12	0.9338	2.333	2.815	0.5908	0.02391	0.4223	0.05749	0.1767	0.03906	0.08057	12.61518 72
Open Parking Garage	0.000171 4	0.04491	1.176	1.44	0.02063	0.7469	0.6226	1.555	1.877	0.3939	0.01594	0.2815	0.03833	0.1178	0.02604	0.05371	8.410431 4
Grocery	0.001097	0.00219 1	0.0369	0.02042	0.00432 2	0.0176	0.01587	0.0266 1	0.04766	0.04194	0.01837	0.05543	0.01988	0.00808 5	0.01128	0.00677 5	0.33443
Refrigerated Warehouse	0	0	0.0346	0.06434	0.01837	0.0164 8	0	0.0022	0.00645 3	0.1149	0	0.1238	0.04495	0.01087	0.02538	0.00506 8	0.467411
Controlled-environment Horticulture	0.0354	0.01232	0.08289	0.01203	0.113	0.0921 3	0.00043 99	0.0103 7	0.00949 5	0.09155	0.2083	0.1008	0.02033	0.00300 1	0.02246	0.00380 4	0.818319 9
Vehicle Service	0.000487 3	0.0141	0.1611	0.1115	0.0163	0.1972	0.1033	0.3019	0.6603	0.1909	0.01615	0.119	0.06246	0.05566	0.02669	0.0498	2.086847 3
Manufacturing	0.004869	0.04419	0.2153	0.2429	0.03568	0.0976 5	0.0338	0.0864 7	0.168	0.3578	0.04713	0.3736	0.0417	0.0595	0.05187	0.02268	1.883139
Unassigned	0.0354	0.01232	0.08289	0.01203	0.113	0.0921 3	0.00043 99	0.0103 7	0.00949 5	0.09155	0.2083	0.1008	0.02033	0.00300 1	0.02246	0.00380 4	0.818319 9
TOTAL	0.141440 76	1.25491 7	18.8338 7	13.3104 08	0.83939 31	8.1456 6	6.95150 98	14.915 6	18.9666 03	16.0239 6	1.53639 84	11.5236 1	2.66974 8	3.63192 8	1.76779 33	1.34841 6	121.8612 6

Source: <https://www.energy.ca.gov/media/3538>

Table 68: Estimated New Nonresidential Construction Impacted by Proposed Code Change in 2026, by Climate Zone and Building Type (Million Square Feet)

Building Type	CZ 1	CZ 2	CZ 3	CZ 4	CZ 5	CZ 6	CZ 7	CZ 8	CZ 9	CZ 10	CZ 11	CZ 12	CZ 13	CZ 14	CZ 15	CZ 16	All CZs
Laboratory	0.000053 95	0.0132 9	0.366 1	0.19	0.00738 7	0.02838	0.02102	0.04858	0.04015	0.08584	0.00286 3	0.01665	0.00496 8	0.00370 7	0.01938	0.00179 5	0.850163 95

Table 69: Percentage of Nonresidential Floorspace Impacted by Proposed Code Change in 2026, by Building Type

Building Type	New Construction Impacted (Percent Square Footage)	Existing Building Stock (Alterations) Impacted (Percent Square Footage)
Large Office	0%	0%
Medium Office	0%	0%
Small Office	0%	0%
Large Retail	0%	0%
Medium Retail	0%	0%
Strip Mall	0%	0%
Mixed-use Retail	0%	0%
Large School	0%	0%
Small School	0%	0%
Non-refrigerated Warehouse	0%	0%
Hotel	0%	0%
Assembly	0%	0%
Hospital	0%	0%
Laboratory	73%	73%
Restaurant	0%	0%
Enclosed Parking Garage	0%	0%
Open Parking Garage	0%	0%
Grocery	0%	0%
Refrigerated Warehouse	0%	0%
Controlled-environment Horticulture	0%	0%
Vehicle Service	0%	0%
Manufacturing	0%	0%
Unassigned	0%	0%

Appendix B: Embedded Electricity in Water Methodology

There are no on-site water savings associated with the proposed code change.

Appendix C: California Building Energy Code Compliance (CBECC) Software Specification

Introduction

The purpose of this appendix is to present proposed revisions to CBECC for commercial buildings (CBECC) along with the supporting documentation that the CEC staff and the technical support contractors would need to approve and implement the software revisions.

Measure: Unoccupied Setback

Existing CBECC Building Energy Modeling Capabilities

The proposed software change would allow CBECC users to change the ventilation method in a lab building from fixed to occupancy based. Currently in CBECC only the “fixed” control ventilation method is supported for labs.

Summary of Proposed Revisions to CBECC

For labs models in CBECC, allow users to select “CO2” ventilation control method. Right now, CBECC restricts ventilation method for labs to “fixed” only.

User Inputs to CBECC

CBECC offers two ventilation methods: fixed and CO2Sensors. For labs space types, the CO2Sensors method isn’t supported. With the proposed code change, CBEC users should be able to select “CO2Sensors” ventilation control method to reflect outside air ventilation controls that are based on occupancy or schedules.

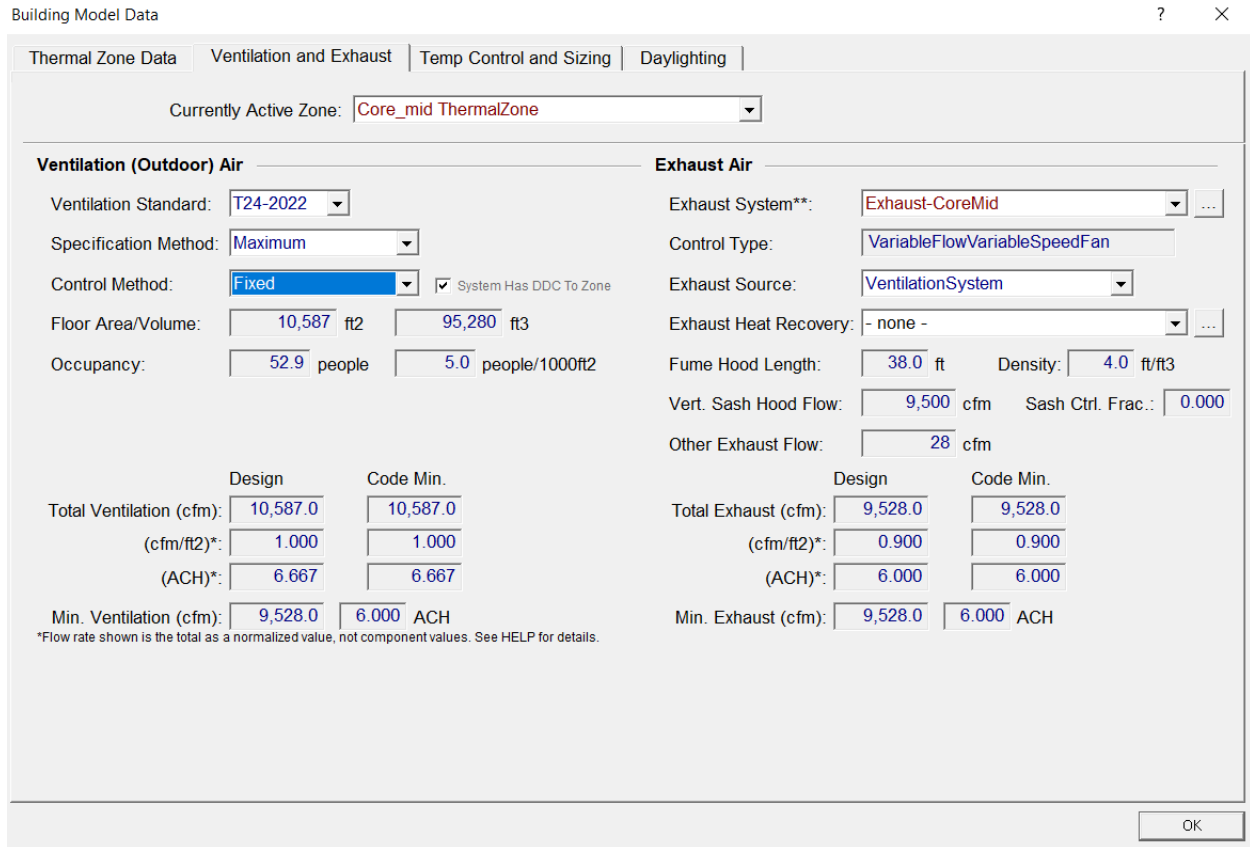

Figure 20: CBECC ventilation and exhaust user interface.

Simulation Engine Inputs

EnergyPlus/California Simulation Engine Inputs

Changing the control method in CBECC from fixed to CO2 sensors would reflect in energy plus input files in the “Controller: Mechanical Ventilation Object”. The demand control ventilation input field within the object would change from no, fixed case, to CO2 sensors, occupancy based.

```

Controller:MechanicalVentilation,
  BaseSys12a OACtrl1-2-2-2-2 Mech Vent Controller, !- Name
  Always On Discrete, !- Availability Schedule Name
  No, !- Demand Controlled Ventilation
  ZoneSum, | !- System Outdoor Air Method
  , !- Zone Maximum Outdoor Air Fraction {dimensionless}
  Core_mid ThermalZone, !- Zone or ZoneList Name 1
  Core_mid ThermalZone Design Specification Outdoor Air, !- Design Specification Outdoor Air Object Name 1
  ; !- Design Specification Zone Air Distribution Object Name 1
  
```

Figure 21: Fixed ventilation scenario.

```

Controller:MechanicalVentilation,
  BaseSys12a OACtrl-2-2-2-2 Mech Vent Controller, !- Name
  Always On Discrete, !- Availability Schedule Name
  yes, !- Demand Controlled Ventilation
  ZoneSum, !- System Outdoor Air Method
  , !- Zone Maximum Outdoor Air Fraction {dimensionless}
  Core_mid ThermalZone, !- Zone or ZoneList Name 1
  Core_mid ThermalZone Design Specification Outdoor Air, !- Design Specification Outdoor Air Object Name 1
  ; !- Design Specification Zone Air Distribution Object Name 1

```

Figure 22: Proposed measure scenario.

Measure: Heat Recovery

There are no recommended revisions to the compliance software as a result of this code change proposal.

Measure: Exhaust Fan Control

Existing CBECC Building Energy Modeling Capabilities

Currently, CBECC assigns a watt per cfm value for fan power and calculates the fan energy based on the fan air flow. The assigned watt per cfm doesn't change and the fan energy varies with the air flow fluctuating.

Summary of Proposed Revisions to CBECC

The proposed revision to EnergyPlus and CBECC includes updating the fan controls strategies that better reflect the energy performance of common exhaust fan control strategies. These include:

Constant exhaust volume, constant speed fan with bypass damper – This is for a system design where the exhaust volume of conditioned air from the lab space is constant but where bypass air is added to increase the velocity of exhaust stack air.

Constant exhaust volume, constant speed fan without bypass damper – This is for a system design where the exhaust volume of conditioned air from the lab space is constant and the same volume is directly exhausted out of the exhaust stack air.

Variable exhaust volume, constant speed fan with bypass damper This is the standard default control system control for a fan system with a design fan power of 0.65 W/cfm for systems without filtration and 0.85 W/cfm for fan systems with filtration. The exhaust volume of conditioned air from the lab space varies in accordance with the larger of: schedules of fume hood fraction, minimum ACH (circulation rate), and airflow required for heating and cooling, however the exhaust fan draws its design power continuously when it is on-line. The remainder of the fan power is to move bypass air which maintains a constant airflow out of the stack.

Variable exhaust volume, variable volume fan without bypass damper – this is an exhaust fan control that varies the volume of conditioned air exhausted from the lab space based on the exhaust load of the space and directly sends this to the exhaust stack. This is often not feasible as the minimum exhaust loads of the lab are less than the minimum volume required to have enough velocity out of the stack to rise sufficient to disperse and dilute to safe levels. This control can more generically be modelled as a variable exhaust volume, variable volume fan control with bypass damper but where the bypass is fixed to 0 cfm.

Variable exhaust volume, variable volume fan with bypass damper – this is an exhaust fan control that varies the volume of conditioned air exhausted from the lab space based on the exhaust load of the space and is exhausted directly out of the exhaust stack when the volumes are high enough to be above the minimum stack velocity needed to provide enough dispersion. The amount or velocity required is a function of how much contaminants are in the exhaust airstream and how fast and from what direction the wind is blowing outside. When more velocity is required, the bypass damper opens and provides added outdoor air so that the mixed exhaust and bypass air provides sufficient airflow to achieve the needed stack velocity.

How much power is required to move this much air is dependent on the control structure of the system. The following three images from an AMCA presentation on this topic illustrate three methods of how to divide the balance of constant and dynamic pressure with respect to airflow in these systems which effects fan energy.

This is a 2021 webinar

<https://www.amca.org/assets/resources/public/Webinars/2021/0113%20-%20Doug%20Ross/FINAL-%20Exhaust%20Fan%20Control%20Systems%20for%20Laboratories%20%281%29.pdf>

Scenario 1: Constant Duct Pressure with pressure sensor in plenum adjacent to exhaust fans.

Bypass damper controlling static pressure (slide 46)

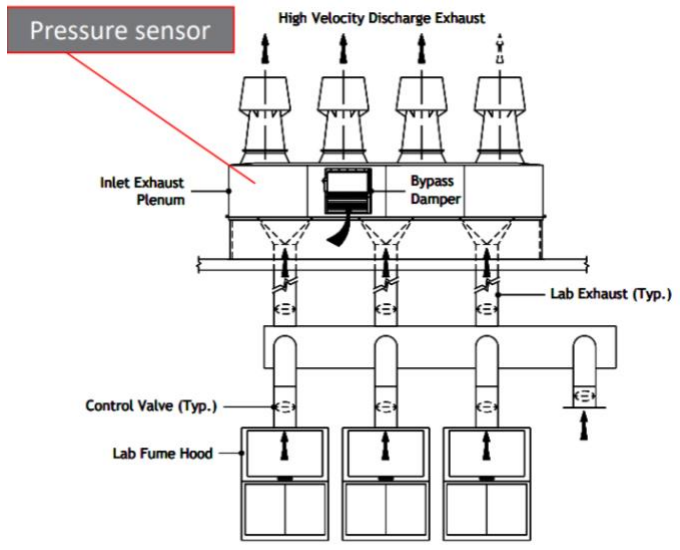

Scenario 2: Variable Duct Pressure with pressure sensor in plenum near loads, limited use of by-pass damper

VFD primarily controlling fixed static pressure (slide 47)

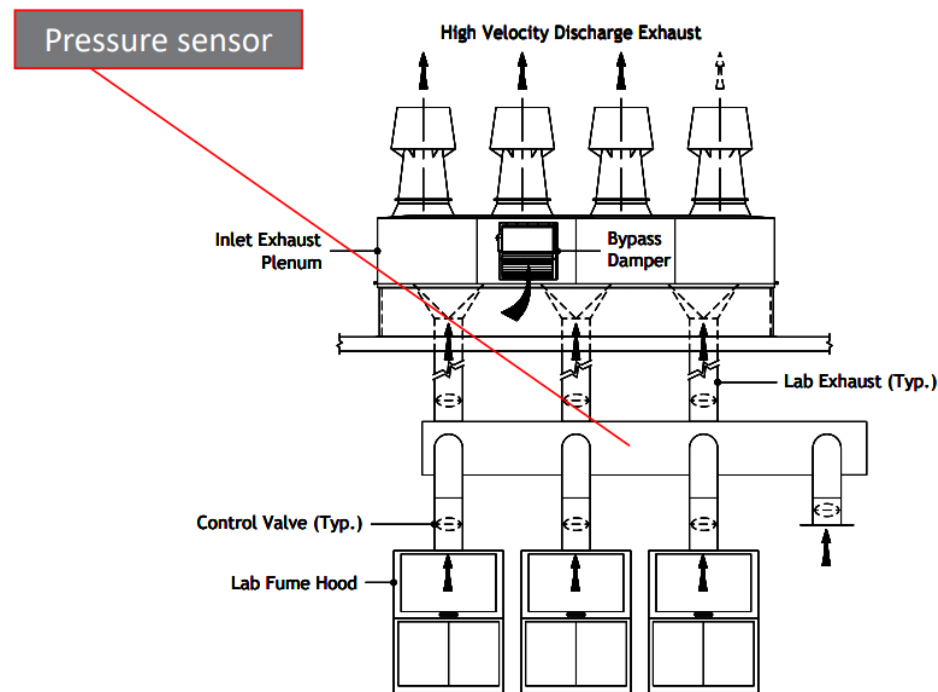

Scenario 3: Variable Duct Pressure with dynamic pressure sensor in plenum near loads

Establishing the static pressure of the system, between the exhaust fans and the lab control valve, in real time. From the earlier text in this presentation, it seems like the control valve pressure sensor is a volumetric measurement through the valve. “DCV Air

control devices: Airflow can be measured with velocity pressure, thermal dispersion or vortex shedding devices.”

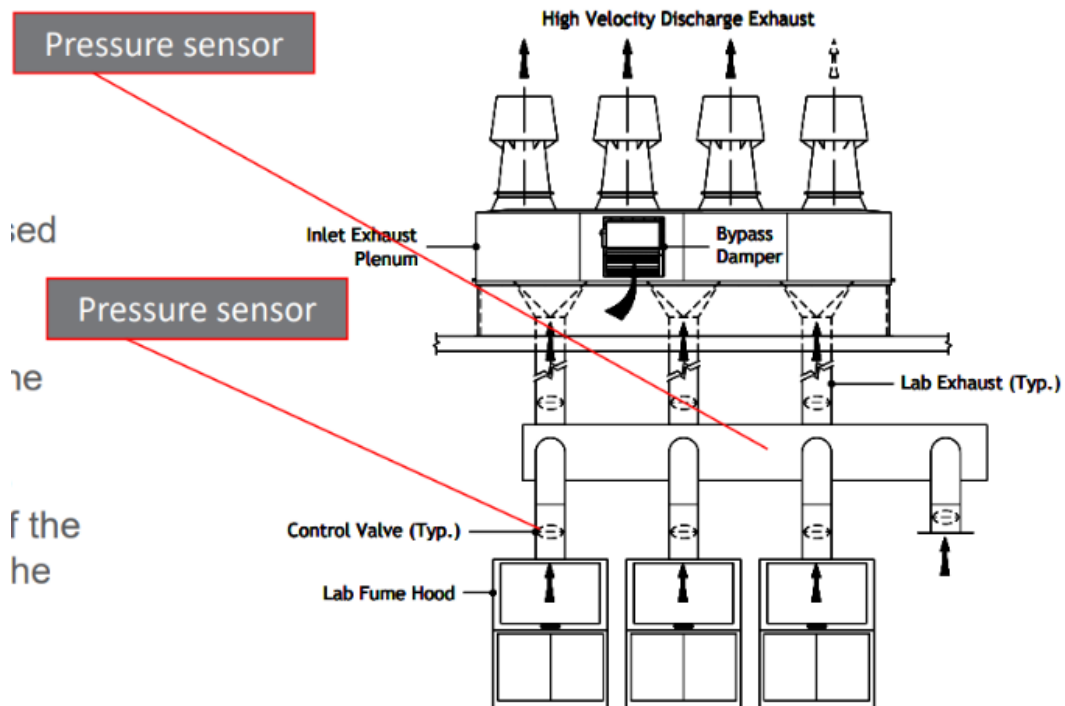

In looking at these three scenarios, the primary difference is where the pressure sensor is located for controlling the fans. The first scenario has the pressure sensor located close to the fans in the plenum serving the fans. This scenario has a large fixed static pressure of all the ductwork upstream of this pressure sensor and a relatively small static pressure which can vary with flowrate which is the pressure rise though the stack downstream of the fan. Stack pressure is higher for induction fans as they include not just the airflow entering the fans but have the added volume of entrained airflow which increases the velocity back pressure in the stack. Bypass air is introduced at the same negative pressure as the rest of the air in the plenum at the control pressure. We have heard from one stakeholder that this is the most common VAV configuration.

The third scenario located the pressure control sensor in a plenum near the load devices (fume hoods etc.). The pressure is set near these end-use devices so there is sufficient negative pressure so there is enough driving force so all the end-use devices have sufficient flow rate, but under reduced airflow rates, pressure drop is relatively low though ducts between the end use device and the fan inlet plenum and as a result there is less fixed static pressure to account for the relatively short duct runs and pressure losses though controls valves between the end use device and where the pressure is located. Additional option 3 contains flow sensing control boxes which allow for

pressure reset so that the system can minimize pressure losses through the control valves. We have heard from one stakeholder that his control is fairly rare.

To implement a fan control simulation that adequately represents this variability in design more inputs are needed.

- Design lab flow rate
- Design by-pass flow rate (not necessary as this is the difference between the design lab flow rate and the fan inlet flow rate)
- Design fan inlet flow rate
- Sum of minimum circulation rates
- Design fan inlet negative static pressure
- Design fan outlet positive static pressure
- Minimum allowable fan inlet flow rate (for induction fans this is the minimum allowable stack flow rate minus the entrained air flow rate)
- Design power

Since compliance is checked based on the scheduled values, a simple way to skirt the W/cfm limit is to just list a lower design BHP, even though the motor may be larger. Correlating input watts to motor size as used in the fan wattage compliance calculations in Section 140.4 may help address this potential compliance gap.

$$(\text{Fan power})_{\text{design}} = C1 \times \text{cfm}_{\text{design}} \times \text{TSP}_{\text{design}}$$

$$(\text{Fan power})_{\text{design}} = C1 \times \text{cfm}_{\text{design}} \times \text{InletSP}_{\text{design}} + C1 \times \text{cfm}_{\text{design}} \times \text{Outlet SP}_{\text{design}}$$

C1 – includes conversion coefficients as well as fan efficiency. The following equations assume that fan efficiency does not decrease with reduced flow, but this could be refined with whatever EnergyPlus currently uses.

TSP_{design} is total static pressure at design conditions

$$C1 = (\text{Fan power})_{\text{design}} / (\text{cfm}_{\text{design}} \times \text{TSP}_{\text{design}})$$

rf – reduced flow at fan inlet

$$(\text{Fan Power})_{\text{rf}} = C1 \times \text{cfm}_{\text{rf}} \times \text{Inlet SP}_{\text{design}} + C1 \times \text{cfm}_{\text{rf}} \times \text{Outlet SP}_{\text{rf}}$$

$$\text{Outlet SP}_{\text{rf}} = \text{Outlet SP}_{\text{design}} \times (\text{cfm}_{\text{rf}}/\text{cfm}_{\text{design}})^2$$

$$(\text{Fan Power})_{\text{rf}} = C1 \times \text{cfm}_{\text{rf}} \times \text{Inlet SP}_{\text{design}} + C1 \times \text{cfm}_{\text{rf}} \times \text{Outlet SP}_{\text{design}} \times (\text{cfm}_{\text{rf}}/\text{cfm}_{\text{design}})^2$$

These equations are based on the control pressure sensor being placed by the fan inlet. These equations could be made to be more generic by defining the design pressure drop upstream of the pressure sensor to the total pressure rise just upstream of the fans and the pressure rise after the fans in the exhaust stacks. This information is not typically available on building plans, but these calculations of pressure rise under design conditions were needed originally to design the duct system and size the fans.

At this point in time, we are unaware of whether EnergyPlus has an existing routine or if one under development that would conduct this calculation with perhaps more accuracy. Ideally and improved model would account for changing fan efficiency with changing flow rate make the pressure and density corrections for the mixed exhaust and ambient airstreams.

User Inputs to CBECC

CBECC has multiple inputs for exhaust fans as shown in the figure below. The inputs include control method, classification, air flow, and power per flow.

The screenshot shows the 'Building Model Data' window with the 'Fan Data' tab selected. The 'Currently Active Fan' is 'Fan 11'. The form contains the following inputs:

Fan Data	
Name:	Fan 11
Control Method:	VariableSpeedDrive
Classification:	Centrifugal
Status:	New
Component Qty:	1
Centrifugal Type:	AirFoil
Capacity and Power (For single system/terminal if Component Qty > 1)	
Flow Capacity:	9,528 cfm
Flow Minimum:	1,906 cfm
Position:	DrawThrough
Modeling Method:	PowerPerUnitFlow
Total Static Pressure:	3.145 inH2O
Fan Efficiency:	0.620
Motor Brake HP:	7.617 hp
Power Per Flow:	0.650 W/cfm
Total Power (Ref):	6.193 kW
Motor Information	
Position:	InAirStream
Nameplate HP:	10.000 hp
Type:	Open
Pole Count:	4
Motor Efficiency:	0.917
Total Efficiency:	0.569
Fan Energy Index (FEI):	1.000
FEI Exception:	Not meeting any EXCEPTIONs

Figure 23- Exhaust fan CBECC inputs.

Simulation Engine Inputs

EnergyPlus/California Simulation Engine Inputs

To model the proposed exhaust fan control in EnergyPlus, the object “Fan:SystemModel” can be used. The object has a speed control input and electric power minimum flow rate input that allow user to select how the fan speed and power vary.

Measure: Reheat Limitation

Existing CBECC Building Energy Modeling Capabilities

Currently, Energy Plus and CBECC doesn't support Air cooled 4 pipe VAV or water cooled 4 pipe VAV. The Statewide CASE Team used a workaround to model reheat limitation in CBECC/Energy Plus. The work around used consisted of using the SZVAV system type for each thermal zone. While this work around captures the main benefits of the reheat limitation measure, it doesn't capture the advantages of interactive effects between different thermal zones when modeled under one main air handler with 4 pipe vav terminal units. Under one main air handler, all the thermal zones can take advantage of the controls options found in the building. For example, if a building uses the proposed HVAC system, air or water cooled 4 pipe VAV, and also implements heat recovery, a thermal zone can take advantage of heat recovered from another thermal zone.

Summary of Proposed Revisions to CBECC

The proposed revision to Energy and CBECC includes adding two new HVAC systems: air cooled 4 pipe VAV and water cooled 4 pipe VAV. This proposed change would allow CBECC to accurately model the reheat limitation measure which is having a central air handler serving all thermal zones and terminal units with 4 pipe fan coils for the cooling at heating. Implementing this change would allow CBEC users to model the reheat limitation measure and account for all the interactive effects between the thermal zones.

User Inputs to CBECC

User inputs in CBECC for HVAC system include system types like PVAV and SZVAV. The proposed measure targets reheat limitation by having the cooling and heating done at the zone level. Using a SZVAV option allows the user to capture the reheat limitation, but it doesn't take into account the interactive benefits of having a main central air handler connected to all the thermal zones with 4 pipe vav terminal units at each thermal zone.

Simulation Engine Inputs

EnergyPlus/California Simulation Engine Inputs

Energy Plus doesn't have a 4 pipe VAV HVAC system type. Therefore, the proposed measure would require Energy Plus to support modeling 4 pipe VAV systems. Currently, Energy Plus has 4 pipe CAV HVAC system type but not a 4 Pipe VAV HVAC system.

Appendix D: Environmental Analysis

Potential Significant Environmental Effect of Proposal

The CEC is the lead agency under the California Environmental Quality Act (CEQA) for the 2025 Energy Code and must evaluate any potential significant environmental effects resulting from the proposed standards. A “significant effect on the environment” is “a substantial adverse change in the physical conditions which exist in the area affected by the proposed project.” (Cal. Code Regs., tit. 14, § 15002(g).)

The Statewide CASE Team has considered the environmental benefits and adverse impacts of its proposal including, but not limited to, an evaluation of factors contained in the California Code of Regulations, Title 14, section 15064 and determined that the proposal will not result in a significant effect on the environment.

Direct Environmental Impacts

Direct environmental benefits are the energy saving associated with each of the four measures and the inclusion of L occupancy spaces into the proposed measures. Reducing overall fan / HVAC energy draw and reducing the peak heating and cooling loads will have a correspondingly lowered GHG production.

Direct Environmental Benefits

The estimated GHG reduction from the proposed measures due to peak load reduction and reduced energy use is 23,590 metric tons.

Direct Adverse Environmental Impacts

There are no adverse environmental impacts currently expected with the proposed measures.

Indirect Environmental Impacts

The Statewide CASE Team did not find any indirect environmental impacts as a result of implementing any of the measures.

Indirect Environmental Benefits

The Statewide CASE Team did not find any indirect environmental benefits aside from the direct benefits listed above.

Direct Adverse Environmental Impacts

The Statewide CASE Team did not find any direct adverse environmental impacts as a consequence of passing the proposed code changes.

Mitigation Measures

“The Statewide CASE Team did not determine this measure would result in significant direct or indirect adverse environmental impacts and therefore, did not develop any mitigation measures.

Reasonable Alternatives to Proposal

The Statewide CASE Team has considered alternatives to the proposal and believes that no alternative achieves the purpose of the proposal with less environmental effect.

Water Use and Water Quality Impacts Methodology

There are no impacts to water quality or water use.

Embodied Carbon in Materials

Accounting for embodied carbon emissions is important for understanding the full picture of a proposed code change’s environmental impacts. The embodied carbon in materials analysis accounts specifically for emissions produced during the “cradle-to-gate” phase: emissions produced from material extraction, manufacturing, and transportation. Understanding these emissions ensures the proposed measure considers these early stages of materials production and manufacturing instead of emissions reductions from energy efficiency alone.

The Statewide CASE Team calculated emissions impacts associated with embodied carbon from the change in materials as a result of the proposed measures. The calculation builds off the materials impacts outlined in 2.5.4, 3.5.4, 4.5.4, and 5.5.4.

After calculating the materials impacts, the Statewide CASE Team applied average embodied carbon emissions for each material. The embodied carbon emissions are

based on industry-wide environmental product declarations (EPDs).^{41, 42} These industry-wide EPDs provide global warming potential (GWP) values per weight of specific materials.⁴³ The Statewide CASE Team chose the industry-wide average for GWP values in the EPDs because the materials accounted for in the statewide calculation will have a range of embodied carbon; i.e. some materials like concrete have a wide range of embodied carbon depending on the manufacturer's processes, source of the materials, etc. The Statewide CASE Team assumes that most building projects will not specify low embodied carbon products. Therefore, an average is appropriate for a statewide estimate.

⁴¹ EPDs are documents which disclose a variety of environmental impacts, including embodied carbon emissions. These documents are based on lifecycle assessments on specific products and materials. Industry-wide EPDs disclose environmental impacts for one product for all (or most) manufacturers in a specified area and are often developed through the coordination of multiple manufacturers and/or associations. A manufacturer specific EPD only examines one product from one manufacturer. Therefore, an industry wide EPD discloses all the environmental impacts from the entire industry (for a specific product/material) but a manufacturer specific EPD only factors one manufacturer.

⁴² An industry wide EPD was not used for mercury, lead, copper, plastics, and refrigerants. Global warming potential values of mercury, lead and copper are based on data provided in a Lifecycle Assessment (LCA) conducted by Yale University in 2014. The GWP value for plastic is based on a LCA conducted by Franklin Associates, which capture roughly 59% of the U.S.' total production of PVC and HDPE production. The GWP values for refrigerants are based on data provided by the Intergovernmental Panel on Climate Change (IPCC) Fourth Assessment Report.

⁴³ GWP values for concrete and wood were in units of kg CO₂ equivalent by volume of the material rather than by weight. An average density of each material was used to convert volume to weight.

Appendix E: Discussion of Impacts of Compliance Process on Market Actors

This appendix discusses how the recommended compliance process, which are described in sections [2.1.5](#), [3.1.5](#), [4.1.5](#), and [5.1.5](#), could impact various market actors. Table 70 identifies the market actors who will play a role in complying with the proposed change, the tasks for which they are responsible, how the proposed code change could impact their existing workflow, and ways negative impacts could be mitigated. The information contained in Table 70 is a summary of key feedback the Statewide CASE Team received when speaking to market actors about the compliance implications of the proposed code changes. Appendix F summarizes the stakeholder engagement that the Statewide CASE Team conducted when developing and refining the code change proposal, including gathering information on the compliance process.

Unoccupied Setback – recommend no new compliance, use a software tool to allow designers to import lab zone schedules with area, occupied ach, unoccupied ach.

Heat Recovery – Existing compliance documents for existing EAHR requirements in 140.4 (q) remain unchanged.

Exhaust Fan Control – NRCA-PRC-14-F must be updated to include this new option, and impacts the permit application phase.

Reheat Limitation – As this measure seeks to limit the amount of reheat exceptions currently in the code, there are no changes to the compliance documents or methods.

Table 70 identifies the market actors who will play a role in complying with the proposed change, the tasks for which they will be responsible, their objectives in completing the tasks, how the proposed code change could impact their existing workflow, and ways negative impacts could be mitigated.

Table 70: Roles of Market Actors in the Proposed Compliance Process

Market Actor	Task(s) in current compliance process relating to the CASE measure	How will the proposed measure impact the current task(s) or workflow?	How will the proposed code change impact compliance and enforcement?	Opportunities to minimize negative impacts of compliance requirement
Mechanical HVAC Designer	<ul style="list-style-type: none"> Design a system with VAV capabilities if ACH is below 10. Ensure that the exhaust fan controls follow at least one of the offered pathways. 	<ul style="list-style-type: none"> Design occupancy sensing and setback abilities based on occupancy. Do not allow for reheat in the design. Design HVAC system with exhaust heat recovery. 	<ul style="list-style-type: none"> None 	<ul style="list-style-type: none"> Training and education for the designers on the new code requirements.
Enforcement Agency Plans Examiner	<ul style="list-style-type: none"> Validate the labs HVAC system meets current Title 24, Part 6 requirements based on submitted plans. 	<ul style="list-style-type: none"> Validate the labs HVAC system meets additional proposed Title 24, Part 6 requirements based on submitted plans 	<ul style="list-style-type: none"> Impact is expected to be minimal relative to current processes. 	<ul style="list-style-type: none"> Consolidation of all new tasks (i.e., new fields in existing form) with existing inspection and approval practices.
CEC	<ul style="list-style-type: none"> Issuance of compliance documentation such as manuals and forms for existing elevator energy efficiency requirements. 	<ul style="list-style-type: none"> Modifications to compliance documentation for proposed code change. 	<ul style="list-style-type: none"> Impact is expected to be minimal relative to current processes 	<ul style="list-style-type: none"> Consolidation of all new tasks into existing compliance form.
ATT	<ul style="list-style-type: none"> For systems with ACH less than 10, ensure the system airflow drops to the unoccupied or nighttime setpoint. 	<ul style="list-style-type: none"> For all systems, ensure that the system can detect occupancy and drops the airflow during unoccupied states. 	<ul style="list-style-type: none"> Previously the ATT only had to test for VAV on labs with a lower ACH, now all labs are required to have a VAV system. 	<ul style="list-style-type: none"> Design tools that can trigger an unoccupied setpoint artificially and have a separate test for the operation of occupancy sensors.

Appendix F: Summary of Stakeholder Engagement

Collaborating with stakeholders that might be impacted by proposed changes is a critical aspect of the Statewide CASE Team's efforts. The Statewide CASE Team aims to work with interested parties to identify and address issues associated with the proposed code changes so that the proposals presented to the CEC in this Draft CASE Report are generally supported. Public stakeholders provide valuable feedback on draft analyses and help identify and address challenges to adoption including: cost effectiveness, market barriers, technical barriers, compliance and enforcement challenges, or potential impacts on human health or the environment. Some stakeholders also provide data that the Statewide CASE Team uses to support analyses.

This appendix summarizes the stakeholder engagement that the Statewide CASE Team conducted when developing and refining the recommendations presented in this report.

Utility-Sponsored Stakeholder Meetings

Utility-sponsored stakeholder meetings provide an opportunity to learn about the Statewide CASE Team's role in the advocacy effort and to hear about specific code change proposals that the Statewide CASE Team is pursuing for the 2025 code cycle. The goal of stakeholder meetings is to solicit input on proposals from stakeholders early enough to ensure the proposals and the supporting analyses are vetted and have as few outstanding issues as possible. To provide transparency in what the Statewide CASE Team is considering for code change proposals, during these meetings the Statewide CASE Team asks for feedback on:

- Proposed code changes
- Draft code language
- Draft assumptions and results for analyses
- Data to support assumptions
- Compliance and enforcement, and
- Technical and market feasibility

The Statewide CASE Team hosted two stakeholder meetings for Labs via webinar described in Table 71. Please see below for dates and links to event pages on Title24Stakeholders.com. Materials from each meeting, such as slide presentations, proposal summaries with code language, and meeting notes, are included in the bibliography section of this report.

Table 71: Utility-Sponsored Stakeholder Meetings

Meeting Name	Meeting Date	Event Page from Title24stakeholders.com
First Round of Industrial Insulation, Labs, Refrigeration, and Elevators Utility-Sponsored Stakeholder Meeting	Tuesday, January 31, 2023	https://title24stakeholders.com/event/nonresidential-industrial-insulation-labs-refrigeration-and-elevators-utility-sponsored-stakeholder-meeting/
Second Round of Covered Process Labs Utility-Sponsored Stakeholder Meeting	Wednesday, May 10, 2023	https://title24stakeholders.com/event/nonresidential-covered-processes-utility-sponsored-stakeholder-meeting-2/

The first round of utility-sponsored stakeholder meetings occurred on January 2023 and were important for providing transparency and an early forum for stakeholders to offer feedback on measures being pursued by the Statewide CASE Team. The objectives of the first round of stakeholder meetings were to solicit input on the scope of the 2025 code cycle proposals; request data and feedback on the specific approaches, assumptions, and methodologies for the energy impacts and cost-effectiveness analyses; and understand potential technical and market barriers. The Statewide CASE Team also presented the initial draft code language for stakeholders to review.

The second round of utility-sponsored stakeholder meetings occurred in May 2023 and provided updated details on proposed code changes. The second round of meetings introduced early results of energy, cost-effectiveness, and incremental cost analyses, and solicited feedback on refined draft code language.

Utility-sponsored stakeholder meetings were open to the public. For each stakeholder meeting, two promotional emails were distributed from info@title24stakeholders.com. One email was sent to the entire Title 24 Stakeholders listserv, totaling over 3,000 individuals, and a second email was sent to a targeted list of individuals on the listserv depending on their subscription preferences. The Title 24 Stakeholders’ website listserv is an opt-in service and includes individuals from a wide variety of industries and trades, including manufacturers, advocacy groups, local government, and building and energy professionals. Each meeting was posted on the Title 24 Stakeholders’ LinkedIn page (and cross-promoted on the CEC LinkedIn page) two weeks before each meeting to reach out to individuals and larger organizations and channels outside of the listserv. The Statewide CASE Team conducted extensive personal outreach to stakeholders identified in initial work plans who had not yet opted into the listserv. Exported webinar meeting data captured attendance numbers and individual comments, and recorded outcomes of live attendee polls to evaluate stakeholder participation and support.

Statewide CASE Team Communications

The Statewide CASE Team held personal communications over email and phone with numerous stakeholders when developing this report, listed in Table 72.

Table 72: Engaged Stakeholders

Organization/Individual Name	Market Role	Mentioned in CASE Report Sections
Brad Cochrane / CPP Wind	Engineering Consultant	No
Jim Coogan / Siemens	Manufacturer	No
Doug Ross / MK Plastics	Manufacturer	No
Blaine Conner / AEI Engineering	Engineering Consultant	No
Megan Hardman / AEI Engineering	Engineering Consultant	No

Appendix G: Energy Cost Savings in Nominal Dollars

The CEC requested energy cost savings over the 30-year period of analysis in both 2026 present value dollars (2026 PV\$) and nominal dollars. The cost-effectiveness analysis uses energy cost values in 2026 PV\$. Costs and cost effectiveness using and 2026 PV\$ are presented in sections 2.4.2, 3.4.2, and 5.4.2 of this report. This appendix presents energy cost savings in nominal dollars. The presented results in Table 73 don't include exhaust fan control proposed measure. The code change proposal would not modify the stringency of the existing California Energy Code, so the CEC does not need a complete cost-effectiveness analysis to approve the proposed change.

Table 73: Combined Nominal LSC Savings Over 30-Year Period of Analysis – Per Square Foot – New Construction – Laboratory- Unoccupied Setback-Heat Recovery-Reheat Limitation

Climate Zone	30-Year Lifecycle Electricity Cost Savings (Nominal \$)	30-Year Lifecycle Natural Gas Cost Savings (Nominal \$)	Total 30-Year LSC Savings (Nominal \$)
2	7.83	31.8	40.5
7	30.83	35.31	66.53
12	13.2	34.94	48.15

Appendix H: Interactive Effects of Different Measures

Each measure for Labs was simulated independently of each other. The interactive effects of all measures being implemented together did not yield a straightforward cumulative effect on GHG reduction or electric savings.